

Low Cost SLIC For Large Telecom Switches

The HC5503PRC is a low cost SLIC optimized for large Telecom switches. It combines a flexible voltage feed architecture with the Intersil latch-free DI bonded wafer process, to provide a low component count, carrier class solution at very low cost. The re-configurable design permits simple, economical solutions for campus-wide call center and PBX applications. External components can be used in conjunction with the high battery voltage capability to meet the complex impedance and long loop drive requirements of Central Office switches, worldwide.

Ordering Information

PART NUMBER	TEMP. RANGE (°C)	PACKAGE	PKG. NO.
HC5503PRCM	0 to 70	28 Ld PLCC	N28.45
HC5503PRCB	0 to 70	24 Ld SOIC	M24.3

Features

- Wide Operating Battery Range (-40V to -58V)
- Single Additional +5V Supply
- 30mA Short Loop Current Limit
- Ring Relay Driver
- Switch Hook and Ring Trip Detect
- Low On-Hook Power Consumption
- On-Hook Transmission
- ITU-T Longitudinal Balance Performance
- Loop Power Denial Function
- Thermal Protection
- Supports Tip, Ring or Balanced Ringing Schemes
- Low Profile SO and PLCC Surface Mount Packaging

Applications

- Central Office, PBX, Call Centers
- Related Literature
 - AN571, Using Ring Sync with HC-5502A and HC-5504 SLICs

Block Diagram

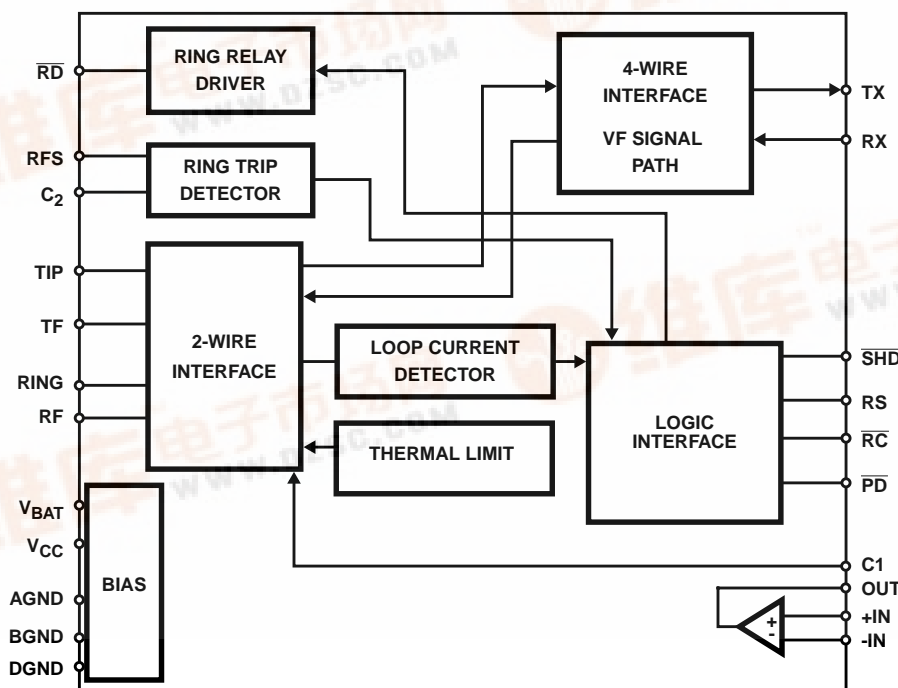

HC5503PRC

Absolute Maximum Ratings (Note 1)

Maximum Continuous Supply Voltages	
(V _{B-})	-60 to 0.5V
(V _{B+})	-0.5 to 7V
(V _{B+} - V _{B-})	.75V
Relay Drive Voltage (V _{RD})	-0.5 to 15V

Operating Conditions

Operating Temperature Range	.0°C to 70°C
Relay Driver Voltage (V _{RD})	5V to 12V
Positive Supply Voltage (V _{B+})	4.75V to 5.25V
Negative Supply Voltage (V _{B-})	-40V to -58V
High Level Logic Input Voltage	2.4V
Low Level Logic Input Voltage	0.6V
Subscriber Loop Resistance	200Ω - 1800Ω

Thermal Information

Thermal Resistance (Typical, Note 2)	θ _{JA} (°C/W)
24 Lead SOIC	75
28 Lead PLCC	65
Maximum Junction Temperature Plastic	150°C
Maximum Storage Temperature Range	-65°C to 150°C
Maximum Lead Temperature (Soldering 10s)	300°C
(PLCC and SOIC - Lead Tips Only)	

Die Characteristics

Transistor Count	185
Diode Count	36
Die Dimensions	137 x 102
Substrate Potential	Connected
Process	Bipolar-DI

CAUTION: Stresses above those listed in "Absolute Maximum Ratings" may cause permanent damage to the device. This is a stress only rating and operation of the device at these or any other conditions above those indicated in the operational sections of this specification is not implied.

NOTES:

1. Absolute maximum ratings are limiting values, applied individually, beyond which the serviceability of the circuit may be impaired. Functional operability under any of these conditions is not necessarily implied.
2. θ_{JA} is measured with the component mounted on an evaluation PC board in free air.

Electrical Specifications Unless Otherwise Specified, V_{B-} = -48V, V_{B+} = 5V, AG = BG = DG = 0V, R_P = 50Ω, R_S = 100Ω, Typical Parameters. T_A = 25°C. Min-Max Parameters are Over Operating Temperature Range

PARAMETER	CONDITIONS	MIN	TYP	MAX	UNITS
On Hook Power Dissipation	I _{LONG} = 0 (Note 4)	-	113	-	mW
Off Hook Power Dissipation	R _L = 600Ω, I _{LONG} = 0 (Notes 3, 4)	-	750	-	mW
On Hook I _{B+}	R _L = ∞, I _{LONG} = 0	-	1.4	-	mA
Off Hook I _{B+}	R _L = 600Ω, I _{LONG} = 0	-	2.8	-	mA
On Hook I _{B-}	R _L = ∞, I _{LONG} = 0	-	2.2	-	mA
Off Hook I _{B-}	R _L = 600Ω, I _{LONG} = 0	-	31	-	mA
Off Hook Loop Current	R _L = 1800Ω (I _{LOOP} = 0)	18	-	-	mA
Off Hook Loop Current	R _L = 200Ω, I _{LONG} = 0 (Note 3)	25	30	35	mA
Fault Currents					
TIP to Ground		-	27	-	mA
RING to Ground		-	55	-	mA
TIP to RING		-	30	-	mA
TIP and RING to Ground		-	69	-	mA
Ring Relay Drive V _{OL}	I _{OL} = 62mA	-	0.2	0.5	V
Ring Relay Driver Off Leakage	V _{RD} = 12V, $\overline{RC} = 1 = \text{HIGH}$, T _A = 25°C	-	-	100	μA
DC Ring Trip Threshold		8.1	10.8	13.5	mA
Switch Hook Detection Threshold		5.0	7.5	10	mA
Loop Current During Power Denial	R _L = 200Ω	-	3.2	-	mA
Dial Pulse Distortion	(Note 4)	0	-	0.5	ms
Receive Input Impedance	(Note 4)	-	110	-	kΩ
Transmit Output Impedance	(Note 4)	-	10	20	Ω

HC5503PRC

Electrical Specifications Unless Otherwise Specified, $V_{B-} = -48V$, $V_{B+} = 5V$, $AG = BG = DG = 0V$, $R_P = 50\Omega$, $R_S = 100\Omega$, Typical Parameters. $T_A = 25^\circ C$. Min-Max Parameters are Over Operating Temperature Range **(Continued)**

PARAMETER	CONDITIONS	MIN	TYP	MAX	UNITS	
2-Wire Return Loss	(Referenced to $600\Omega + 2.16\mu F$), $R_P = R_S = 150\Omega$ (Note 4)	-	15.5	-	dB	
SR _L LO		-	24	-	dB	
ER _L		-	31	-	dB	
SR _L HI						
Longitudinal Balance	1V _{RMS} 200Hz - 3400Hz, (Note 4) IEEE Method $0^\circ C \leq T_A \leq 75^\circ C$, $R_P = R_S = 150\Omega$	53	58	-	dB	
2-Wire Off Hook (Note 4)		53	58	-	dB	
2-Wire On Hook (Note 4)		50	58	-	dB	
4-Wire Off Hook						
Insertion Loss	At 1kHz, 0dBm Input Level, Referenced 600Ω , $R_P = R_S = 150\Omega$	-	± 0.05	± 0.2	dB	
2-Wire to 4-Wire, 4-Wire to 2-Wire						
Frequency Response	200 - 3400Hz Referenced to Absolute Loss at 1kHz and 0dBm Signal Level, $R_P = R_S = 150\Omega$ (Note 4)	-	± 0.02	± 0.05	dB	
Idle Channel Noise	$R_P = R_S = 150\Omega$ (Note 4)	-	1	5	dBrnC	
2-Wire to 4-Wire, 4-Wire to 2-Wire		-	-89	-85	dBm0p	
Absolute Delay	$R_P = R_S = 150\Omega$ (Note 4)	-	-	2	μs	
2-Wire to 4-Wire, 4-Wire to 2-Wire						
Trans Hybrid Loss	Balance Network Set Up for 600Ω Termination at 1kHz, $R_P = R_S = 150\Omega$ (Note 4)	30	40	-	dB	
Overload Level	$V_{B+} = +5V$, $R_P = R_S = 150\Omega$ (Note 4)	1.5	-	-	V_{PEAK}	
2-Wire to 4-Wire, 4-Wire to 2-Wire						
Level Linearity	At 1kHz, (Note 4) Referenced to 0dBm Level, $R_P = R_S = 150\Omega$	-	-	± 0.05	dB	
2-Wire to 4-Wire, 4-Wire to 2-Wire (Note 4)		+3 to -40dBm	-	-	± 0.1	dB
		-40 to -50dBm	-	-	± 0.3	dB
	-50 to -55dBm	-	-		dB	
Power Supply Rejection Ratio	$R_P = R_S = 150\Omega$ (Note 4) 30 - 60Hz, $R_L = 600\Omega$	15	-	-	dB	
V_{B+} to 2-Wire		15	-	-	dB	
V_{B+} to Transmit		15	-	-	dB	
V_{B-} to 2-Wire		15	-	-	dB	
V_{B-} to Transmit						
V_{B+} to 2-Wire	200 - 16kHz, $R_L = 600\Omega$, $R_P = R_S = 150\Omega$	30	-	-	dB	
V_{B+} to Transmit		30	-	-	dB	
V_{B-} to 2-Wire		30	-	-	dB	
V_{B-} to Transmit		30	-	-	dB	
Logic Input Current (RS, RC, PD)	$0V \leq V_{IN} \leq 5V$	-	-	± 100	μA	
Logic Inputs						
Logic '0' V_{IL}		-	-	0.8	V	
Logic '1' V_{IH}		2.0	-	5.5	V	
Logic Outputs						
Logic '0' V_{OL}	$I_{LOAD} 800\mu A$, $V_{B+} = 5V$	-	0.1	0.5	V	
Logic '1' V_{OH}	$I_{LOAD} 40\mu A$, $V_{B+} = 5V$	2.7	-	5.0	V	

HC5503PRC

Electrical Specifications Unless Otherwise Specified, $V_{B-} = -48V$, $V_{B+} = 5V$, $AG = BG = DG = 0V$, $R_P = 50\Omega$, $R_S = 100\Omega$, Typical Parameters. $T_A = 25^\circ C$. Min-Max Parameters are Over Operating Temperature Range **(Continued)**

PARAMETER	CONDITIONS	MIN	TYP	MAX	UNITS
UNCOMMITTED OP AMP SPECIFICATIONS					
Input Offset Voltage		-	± 5	-	mV
Input Offset Current		-	± 10	-	nA
Input Bias Current		-	20	-	nA
Differential Input Resistance	(Note 4)	-	1	-	$M\Omega$
Output Voltage Swing	$R_L = 10K$, $V_{B+} = 5V$	-	± 3	-	V_{PEAK}
Output Resistance	$A_{VCL} = 1$ (Note 4)	-	10	-	Ω
Small Signal GBW	(Note 4)	-	1	-	MHZ

NOTES:

3. I_{LONG} = Longitudinal Current
4. These parameters are controlled by design or process parameters and are not directly tested. These parameters are characterized upon initial design release, upon design changes which would affect these characteristics, and at intervals to assure product quality and specification compliance.

Pin Descriptions

28 PIN PLCC	24 PIN DIP/SOIC	SYMBOL	DESCRIPTION
2	1	TIP	An analog input connected to the TIP (more positive) side of the subscriber loop through a sense resistor (R_S) and a ring relay contact. Functions with the Ring terminal to receive voice signals from the telephone and for loop monitoring purposes.
3	2	RING	An analog input connected to the RING (more negative) side of the subscriber loop through a sense resistor (R_S) and a ring relay contact. Functions with the Tip terminal to receive voice signals from the telephone and for loop monitoring purposes.
4	3	RFS	Senses ring side of loop for ground key and ring trip detection. During ringing, the ring signal is inserted into the line at this node and RF is isolated from RFS via a relay.
5	4	V_{B+}	Positive Voltage Source - Most positive supply. V_{B+} is typically.
6	5	C_1	Capacitor #1 - An external capacitor to be connected between this terminal and analog ground. Required for proper operation of the loop current limiting function, and for filtering V_{B-} . Typical value is $0.3\mu F$, 30V.
7	6	DG	Digital Ground - To be connected to zero potential and serves as a reference for all digital inputs and outputs on the SLIC microcircuit.
9	7	RS	Ring Synchronization Input - A TTL - compatible clock input. The clock should be arranged such that a positive pulse transition occurs on the zero crossing of the ring voltage source, as it appears at the RFS terminal. For Tip side injected systems, the RS pulse should occur on the negative going zero crossing and for Ring injected systems, on the positive going zero crossing. This ensures that the ring relay activates and deactivates when the instantaneous ring voltage is near zero. If synchronization is not required, the pin should be tied to 5V.
10	8	\overline{RD}	Relay Driver - A low active open collector logic output. When enabled, the external ring relay is energized.
11	9	TF	Tip Feed - A low impedance analog output connected to the TIP terminal through a sense resistor (R_S). Functions with the RF terminal to provide loop current, feed voice signals to the telephone set, and sink longitudinal current.
12	10	RF	Ring Feed - A low impedance analog output connected to the RING terminal through a sense resistor (R_S). Functions with the TF terminal to provide loop current, feed voice signals to the telephone set, and sink longitudinal current.
13	11	V_{B-}	Negative Voltage Source - Most negative supply. V_{B-} is typically -48V with an operational range of -42V to -58V. Frequently referred to as "battery".
14	12	BG	Battery Ground - To be connected to zero potential. All loop current and some quiescent current flows into this ground terminal.
16	13	\overline{SHD}	Switch Hook Detection - A low active LS TTL - compatible logic output. This output is enabled for loop currents exceeding the switch hook threshold.
17	14	NC	Used during production test. Leave disconnected.

HC5503PRC

Pin Descriptions (Continued)

28 PIN PLCC	24 PIN DIP/SOIC	SYMBOL	DESCRIPTION
18	15	$\overline{\text{PD}}$	Power Denial - A low active TTL - Compatible logic input. When enabled, the ring feed voltage collapses to the tip feed voltage ($\sim 4\text{V}$). The DC feed is disabled, but the AC transmission is maintained. The switch hook detect (SHD) is not necessarily valid, and the relay driver (RD) output is disabled.
19	16	RC	Ring Command - A low active TTL - Compatible logic input. When enabled, the relay driver ($\overline{\text{RD}}$) output goes low on the next high level of the ring sync (RS) input, as long as the SLIC is not in the power denial state ($\overline{\text{PD}} = 0$) or the subscriber is not already off-hook ($\overline{\text{SHD}} = 0$).
20	17	NC	Leave disconnected.
21	18	OUT	The analog output of the spare operational amplifier.
23	19	-IN	The inverting analog input of the spare operational amplifier.
24	20	+IN	The non-inverting analog input of the spare operational amplifier.
25	21	RX	Receive Input, Four Wire Side - A high impedance analog input which is internally biased. Capacitive coupling to this input is required. AC signals appearing at this input differentially drive the Tip feed and Ring feed terminals.
26	22	C_2	Capacitor #2 - An external capacitor to be connected between this terminal and analog ground. This capacitor is required for the proper operation of ring trip detection. Recommended value $0.82\mu\text{F} \pm 10\%$ 10V non-polarized.
27	23	AG	Analog Ground - To be connected to zero potential and serves as a reference for the transmit output (TX) and receive input (RX) terminals.
28	24	TX	Transmit Output, Four Wire Side - A low impedance analog output proportional to the loop current. Transhybrid balancing must be performed beyond this output to completely implement two to four wire conversion. This output is unbalanced and referenced to analog ground. Since the DC level of this output varies with loop current, capacitive coupling to the next stage is essential.
1, 8, 15, 22		NC	No internal connection.

NOTE: All grounds (AG, BG, and DG) must be applied before $\text{V}_{\text{B}+}$ or $\text{V}_{\text{B}-}$. Failure to do so may result in premature failure of the part. If a user wishes to run separate grounds off a line card, the AG must be applied first.

Functional Diagram

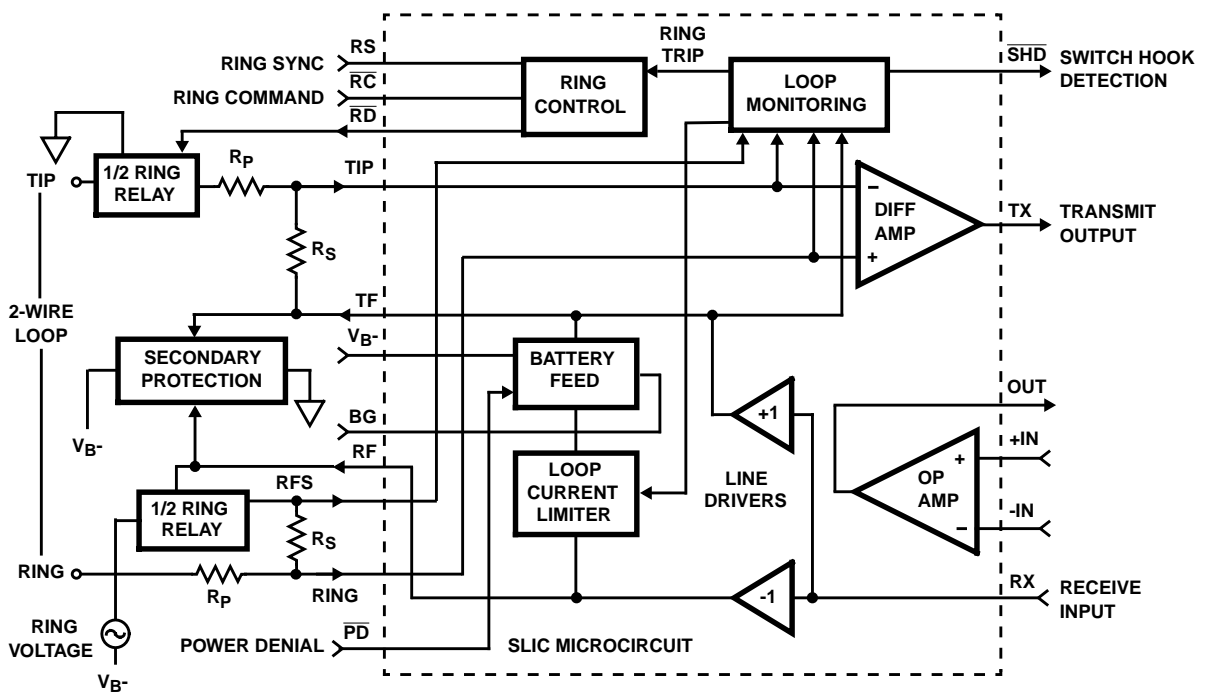

R_S : SENSE RESISTOR
 R_P : PROTECTION RESISTOR

HC5503PRC

SLIC FUNCTIONAL SCHEMATIC SOIC PIN NUMBERS SHOWN

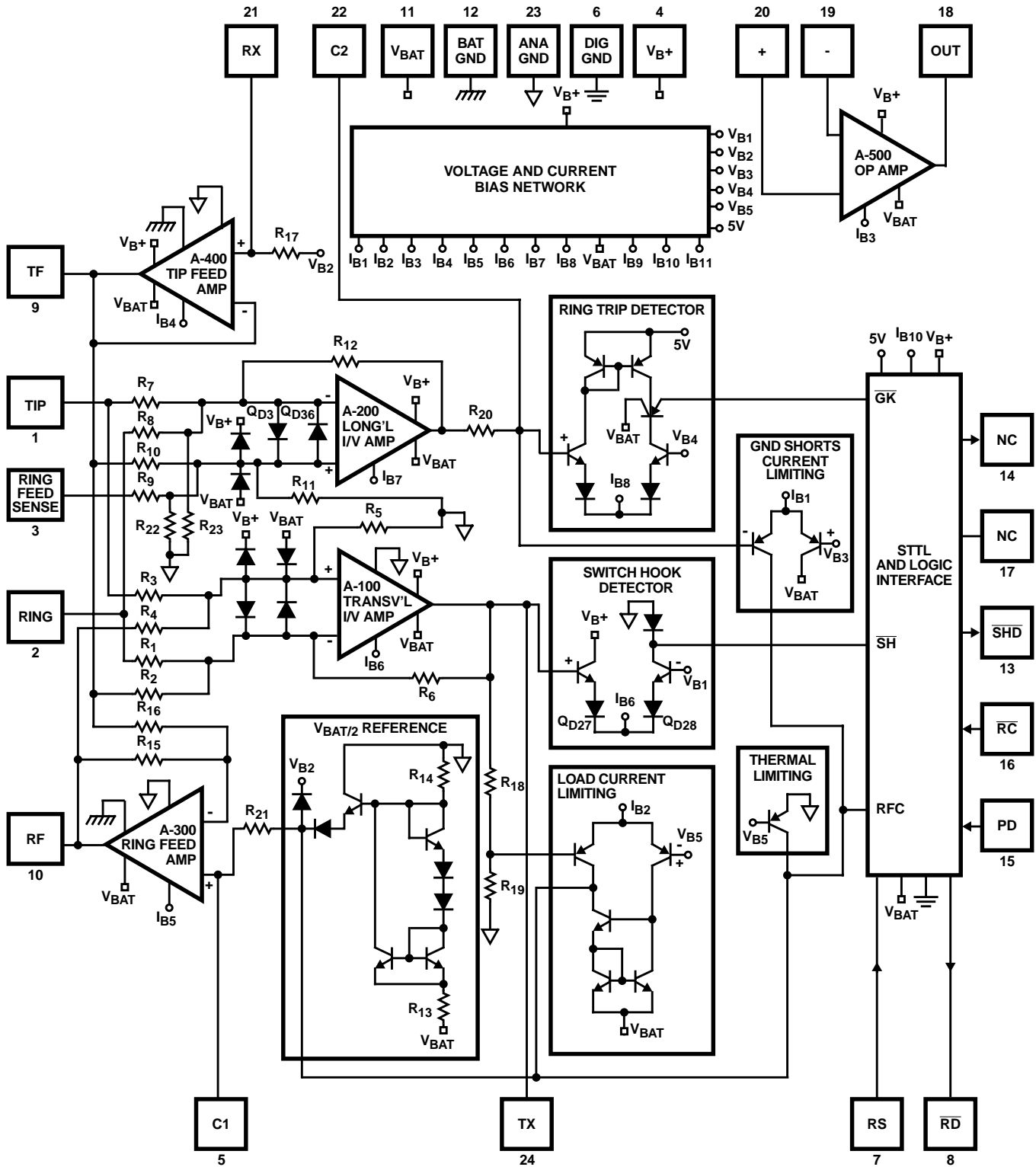

HC5503PRC

LOGIC GATE SCHEMATIC

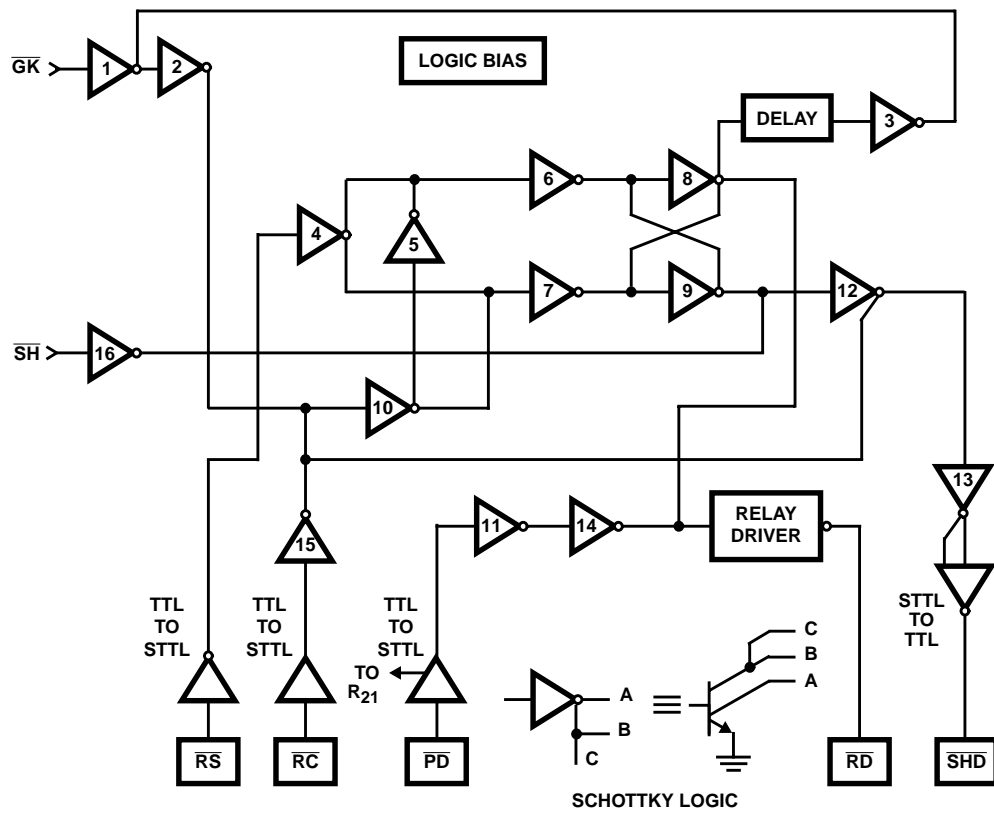

Surge Protection

The SLIC device, in conjunction with an external protection bridge, will withstand high voltage lightning surges and power line crosses.

The voltage withstand capability of pins 'Tip', 'Ring' and 'RFs' is $\pm 450V$ with respect to ground, as shown in Table 1.

This device is intended for use with an appropriate secondary protection circuit scheme.

The SLIC will withstand longitudinal currents up to a maximum of $30mARMS$, $15mARMS$ per leg, without any performance degradation.

TABLE 1.

PARAMETER	TEST CONDITION	PERFORMANCE (MAX)	UNITS
Longitudinal Surge	10 μs Rise/ 1000 μs Fall	± 450 (Plastic)	V_{PEAK}
Metallic Surge	10 μs Rise/ 1000 μs Fall	± 450 (Plastic)	V_{PEAK}
T/GND R/GND	10 μs Rise/ 1000 μs Fall	± 450 (Plastic)	V_{PEAK}
50/60Hz Current T/GND R/GND	11 Cycles Limited to 10 A_{RMS}	315 (Plastic)	V_{RMS}

HC5503PRC

Plastic Leaded Chip Carrier Packages (PLCC)

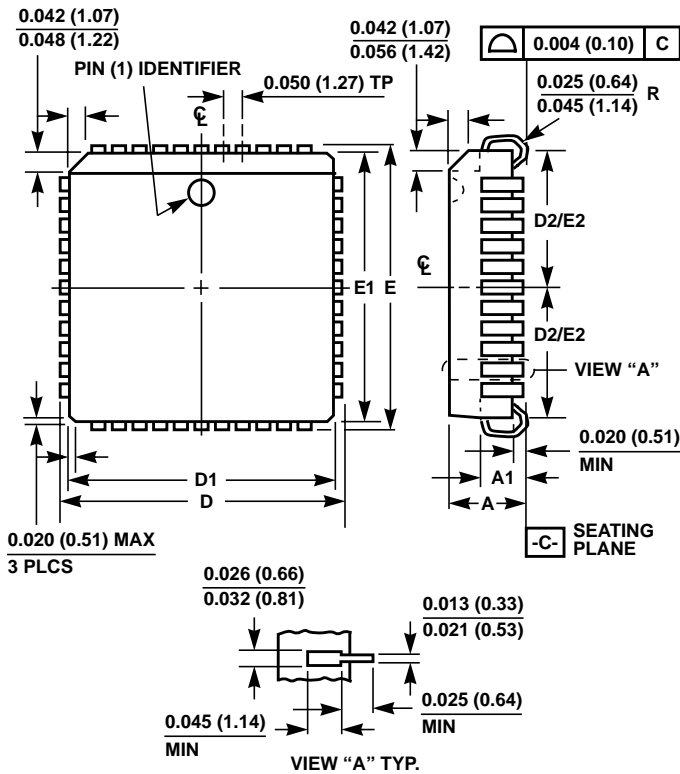

N28.45 (JEDEC MS-018AB ISSUE A) 28 LEAD PLASTIC LEADED CHIP CARRIER PACKAGE

SYMBOL	INCHES		MILLIMETERS		NOTES
	MIN	MAX	MIN	MAX	
A	0.165	0.180	4.20	4.57	-
A1	0.090	0.120	2.29	3.04	-
D	0.485	0.495	12.32	12.57	-
D1	0.450	0.456	11.43	11.58	3
D2	0.191	0.219	4.86	5.56	4, 5
E	0.485	0.495	12.32	12.57	-
E1	0.450	0.456	11.43	11.58	3
E2	0.191	0.219	4.86	5.56	4, 5
N	28		28		6

Rev. 2 11/97

NOTES:

1. Controlling dimension: INCH. Converted millimeter dimensions are not necessarily exact.
2. Dimensions and tolerancing per ANSI Y14.5M-1982.
3. Dimensions D1 and E1 do not include mold protrusions. Allowable mold protrusion is 0.010 inch (0.25mm) per side. Dimensions D1 and E1 include mold mismatch and are measured at the extreme material condition at the body parting line.
4. To be measured at seating plane [-C-] contact point.
5. Centerline to be determined where center leads exit plastic body.
6. "N" is the number of terminal positions.

HC5503PRC

Small Outline Plastic Packages (SOIC)

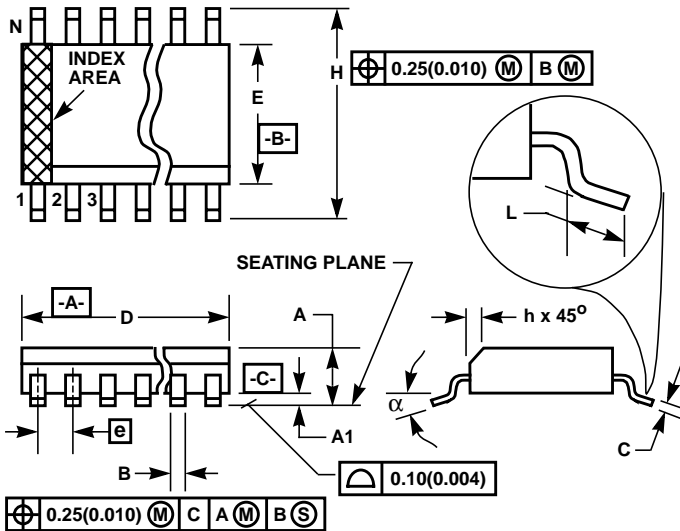

M24.3 (JEDEC MS-013-AD ISSUE C) 24 LEAD WIDE BODY SMALL OUTLINE PLASTIC PACKAGE

SYMBOL	INCHES		MILLIMETERS		NOTES
	MIN	MAX	MIN	MAX	
A	0.0926	0.1043	2.35	2.65	-
A1	0.0040	0.0118	0.10	0.30	-
B	0.013	0.020	0.33	0.51	9
C	0.0091	0.0125	0.23	0.32	-
D	0.5985	0.6141	15.20	15.60	3
E	0.2914	0.2992	7.40	7.60	4
e	0.05 BSC		1.27 BSC		-
H	0.394	0.419	10.00	10.65	-
h	0.010	0.029	0.25	0.75	5
L	0.016	0.050	0.40	1.27	6
N	24		24		7
α	0°	8°	0°	8°	-

NOTES:

- Symbols are defined in the "MO Series Symbol List" in Section 2.2 of Publication Number 95.
- Dimensioning and tolerancing per ANSI Y14.5M-1982.
- Dimension "D" does not include mold flash, protrusions or gate burrs. Mold flash, protrusion and gate burrs shall not exceed 0.15mm (0.006 inch) per side.
- Dimension "E" does not include interlead flash or protrusions. Interlead flash and protrusions shall not exceed 0.25mm (0.010 inch) per side.
- The chamfer on the body is optional. If it is not present, a visual index feature must be located within the crosshatched area.
- "L" is the length of terminal for soldering to a substrate.
- "N" is the number of terminal positions.
- Terminal numbers are shown for reference only.
- The lead width "B", as measured 0.36mm (0.014 inch) or greater above the seating plane, shall not exceed a maximum value of 0.61mm (0.024 inch)
- Controlling dimension: MILLIMETER. Converted inch dimensions are not necessarily exact.

Rev. 0 12/93

All Intersil semiconductor products are manufactured, assembled and tested under **ISO9000** quality systems certification.

Intersil semiconductor products are sold by description only. Intersil Corporation reserves the right to make changes in circuit design and/or specifications at any time without notice. Accordingly, the reader is cautioned to verify that data sheets are current before placing orders. Information furnished by Intersil is believed to be accurate and reliable. However, no responsibility is assumed by Intersil or its subsidiaries for its use; nor for any infringements of patents or other rights of third parties which may result from its use. No license is granted by implication or otherwise under any patent or patent rights of Intersil or its subsidiaries.

For information regarding Intersil Corporation and its products, see web site www.intersil.com

Sales Office Headquarters

NORTH AMERICA

Intersil Corporation
P. O. Box 883, Mail Stop 53-204
Melbourne, FL 32902
TEL: (321) 724-7000
FAX: (321) 724-7240

EUROPE

Intersil SA
Mercure Center
100, Rue de la Fusee
1130 Brussels, Belgium
TEL: (32) 2.724.2111
FAX: (32) 2.724.22.05

ASIA

Intersil (Taiwan) Ltd.
7F-6, No. 101 Fu Hsing North Road
Taipei, Taiwan
Republic of China
TEL: (886) 2 2716 9310
FAX: (886) 2 2715 3029