

10A, 30V, 0.0135 Ohm, Single N-Channel, Logic Level Power MOSFET

This power MOSFET is manufactured using an innovative process. This advanced process technology achieves the lowest possible on-resistance per silicon area, resulting in outstanding performance. This device is capable of withstanding high energy in the avalanche mode and the diode exhibits very low reverse recovery time and stored charge. It was designed for use in applications where power efficiency is important, such as switching regulators, switching converters, motor drivers, relay drivers, low-voltage bus switches, and power management in portable and battery-operated products.

Ordering Information

PART NUMBER	PACKAGE	BRAND
HP4410DY	SO-8	P4410DY

NOTE: When ordering, use the entire part number. Add the suffix T to obtain the variant in tape and reel, e.g., HP4410DYT.

Features

- Logic Level Gate Drive
- 10A, 30V
- $r_{DS(ON)} = 0.0135\Omega$ at $I_D = 10A, V_{GS} = 10V$
- $r_{DS(ON)} = 0.020\Omega$ at $I_D = 8A, V_{GS} = 4.5V$
- Related Literature
 - TB334, "Guidelines for Soldering Surface Mount Components to PC Boards"

Symbol

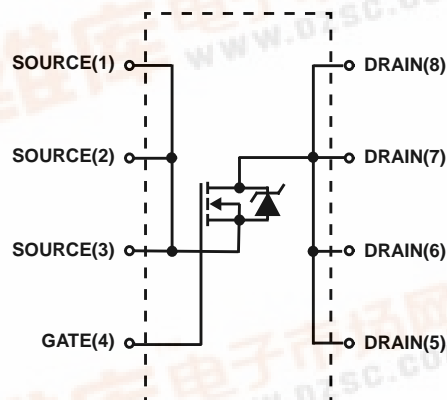

Packaging

SO-8

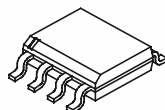

HP4410DY

Absolute Maximum Ratings $T_A = 25^\circ\text{C}$, Unless Otherwise Specified

	HP4410DY	UNITS
Drain to Source Voltage (Note 1)	30	V
Drain to Gate Voltage ($R_{GS} = 20k\Omega$) (Note 1)	30	V
Gate to Source Voltage	± 16	V
Drain Current		
Continuous	10	A
Pulsed Drain Current (10 μ s Pulse Width)	50	A
Power Dissipation	2.5	W
Derate Above 25 $^\circ\text{C}$	0.02	W/ $^\circ\text{C}$
Operating and Storage Temperature	-55 to 150	$^\circ\text{C}$
Maximum Temperature for Soldering		
Leads at 0.063in (1.6mm) from Case for 10s	300	$^\circ\text{C}$
Package Body for 10s, See Techbrief 334	260	$^\circ\text{C}$

CAUTION: Stresses above those listed in "Absolute Maximum Ratings" may cause permanent damage to the device. This is a stress only rating and operation of the device at these or any other conditions above those indicated in the operational sections of this specification is not implied.

NOTE:

1. $T_A = 25^\circ\text{C}$ to 125 $^\circ\text{C}$.

Electrical Specifications $T_A = 25^\circ\text{C}$, Unless Otherwise Specified

PARAMETER	SYMBOL	TEST CONDITIONS	MIN	TYP	MAX	UNITS
Drain to Source Breakdown Voltage	BV_{DSS}	$I_D = 250\mu\text{A}$, $V_{GS} = 0\text{V}$	30	-	-	V
Gate to Source Threshold Voltage	$V_{GS(TH)}$	$V_{GS} = V_{DS}$, $I_D = 250\mu\text{A}$ (Figure 9)	1	-	-	V
Zero Gate Voltage Drain Current	I_{DSS}	$V_{DS} = 30\text{V}$, $V_{GS} = 0\text{V}$	-	-	1	μA
		$V_{DS} = 30\text{V}$, $V_{GS} = 0\text{V}$, $T_A = 55^\circ\text{C}$	-	-	25	μA
Gate to Source Leakage Current	I_{GSS}	$V_{GS} = \pm 16\text{V}$	-	-	100	nA
Drain to Source On Resistance	$r_{DS(ON)}$	$I_D = 8\text{A}$, $V_{GS} = 4.5\text{V}$ (Figures 6, 8)	-	0.015	0.020	Ω
		$I_D = 10\text{A}$, $V_{GS} = 10\text{V}$ (Figures 6, 8)	-	0.011	0.0135	Ω
Turn-On Delay Time	$t_{d(ON)}$	$V_{DD} = 25\text{V}$, $I_D \cong 1\text{A}$, $R_L = 25\Omega$, $V_{GEN} = 10\text{V}$, $R_{GS} = 6\Omega$	-	15	30	ns
Rise Time	t_r		-	9	20	ns
Turn-Off Delay Time	$t_{d(OFF)}$		-	70	100	ns
Fall Time	t_f		-	20	80	ns
Total Gate Charge	$Q_{g(TOT)}$	$V_{DS} = 15\text{V}$, $V_{GS} = 10\text{V}$, $I_D \cong 10\text{A}$	-	35	60	nC
Gate to Source Charge	Q_{gs}		-	7.5	-	nC
Gate to Drain Charge	Q_{gd}		-	5.8	-	nC
Input Capacitance	C_{ISS}	$V_{DS} = 25\text{V}$, $V_{GS} = 0\text{V}$, $f = 1\text{MHz}$ (Figure 4)	-	1600	-	pF
Output Capacitance	C_{OSS}		-	685	-	pF
Reverse Transfer Capacitance	C_{RSS}		-	115	-	pF
Thermal Resistance Junction to Ambient	$R_{\theta JA}$	Pulse Width < 10s (Figure 11) Device Mounted on FR-4 Material	-	-	50	$^\circ\text{C/W}$

Source to Drain Diode Specifications

PARAMETER	SYMBOL	TEST CONDITIONS	MIN	TYP	MAX	UNITS
Source to Drain Diode Voltage	V_{SD}	$I_{SD} = 2.3\text{A}$ (Figure 7)	-	0.75	1.1	V
Reverse Recovery Time	t_{rr}	$I_{SD} = 2.3\text{A}$, $dI_{SD}/dt = 100\text{A}/\mu\text{s}$	-	50	80	ns

HP4410DY

Typical Performance Curves Unless Otherwise Specified

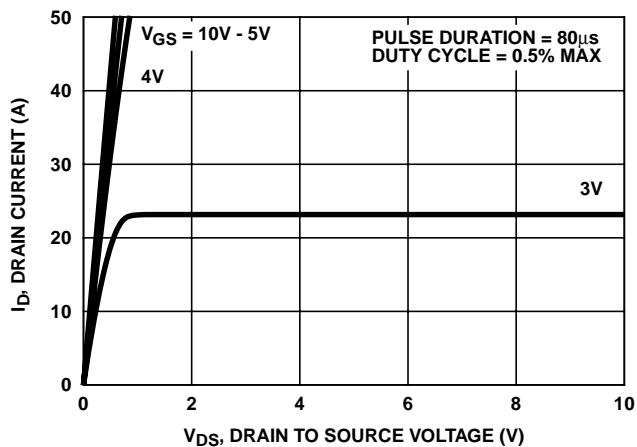

FIGURE 1. OUTPUT CHARACTERISTICS

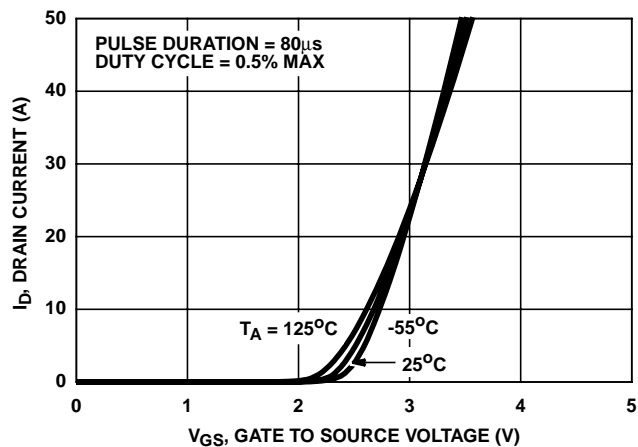

FIGURE 2. TRANSFER CHARACTERISTICS

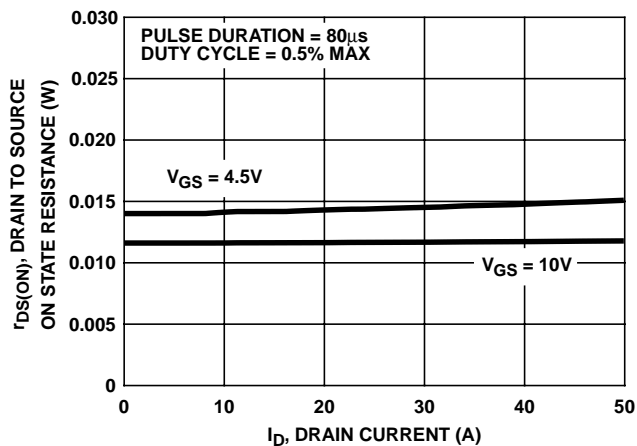

FIGURE 3. DRAIN TO SOURCE ON RESISTANCE vs GATE VOLTAGE AND DRAIN CURRENT

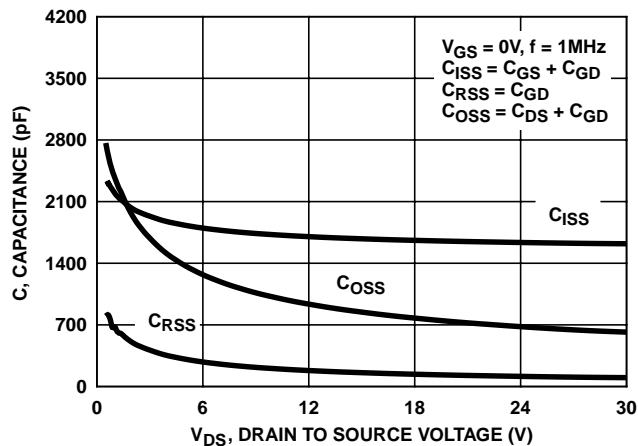

FIGURE 4. CAPACITANCE vs DRAIN TO SOURCE VOLTAGE

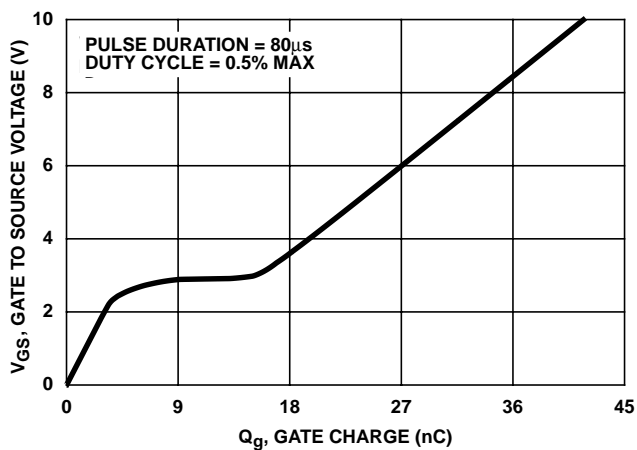

FIGURE 5. GATE TO SOURCE VOLTAGE vs GATE CHARGE

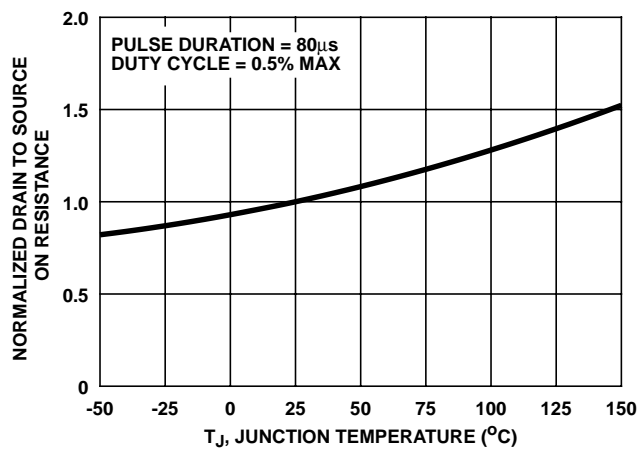

FIGURE 6. NORMALIZED DRAIN TO SOURCE ON RESISTANCE vs JUNCTION TEMPERATURE

HP4410DY

Typical Performance Curves Unless Otherwise Specified (Continued)

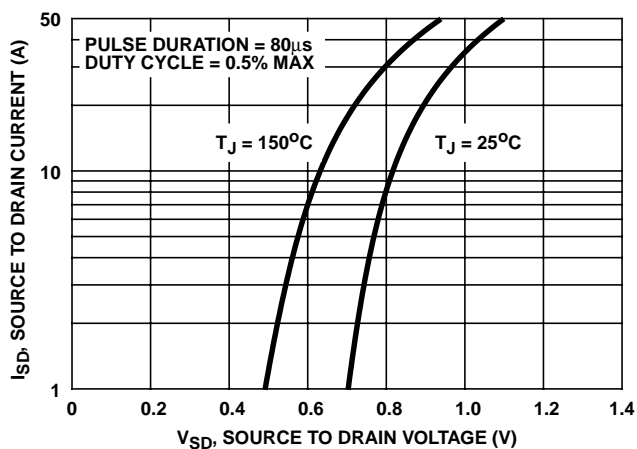

FIGURE 7. SOURCE TO DRAIN DIODE VOLTAGE

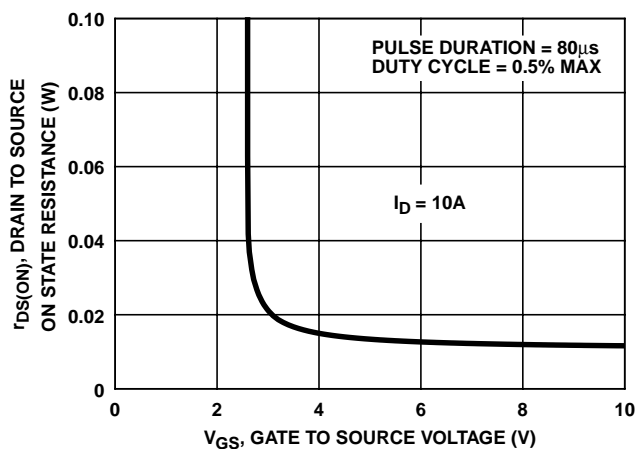

FIGURE 8. DRAIN TO SOURCE ON RESISTANCE vs GATE TO SOURCE VOLTAGE

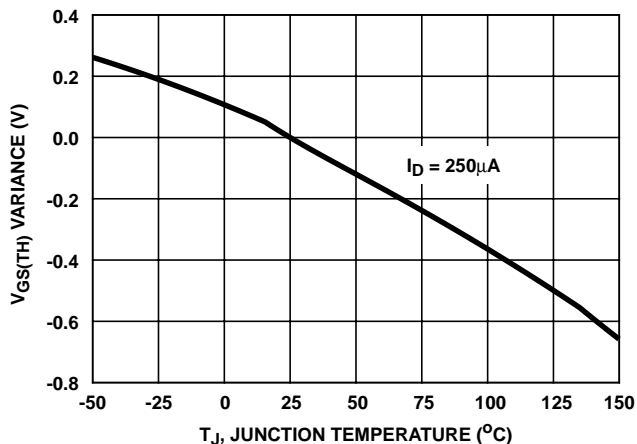

FIGURE 9. GATE THRESHOLD VOLTAGE VARIANCE vs JUNCTION TEMPERATURE

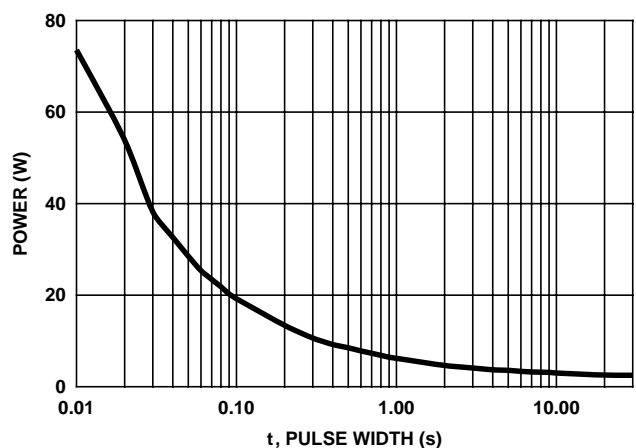

FIGURE 10. SINGLE PULSE POWER CAPABILITY vs PULSE WIDTH

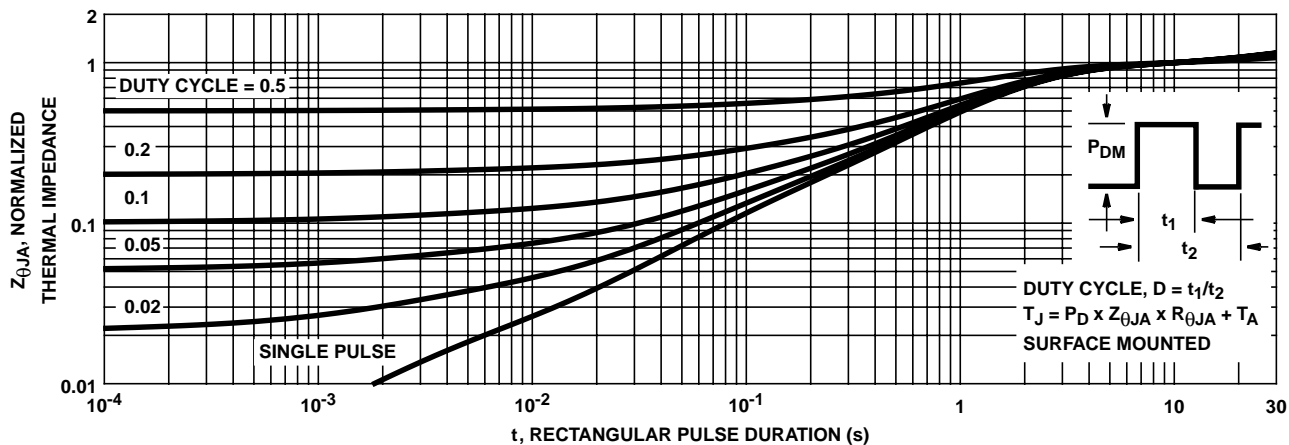

FIGURE 11. NORMALIZED MAXIMUM TRANSIENT THERMAL IMPEDANCE

Test Circuits and Waveforms

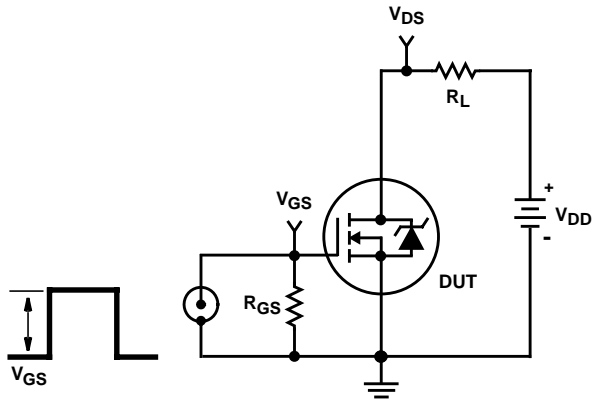

FIGURE 12. SWITCHING TIME TEST CIRCUIT

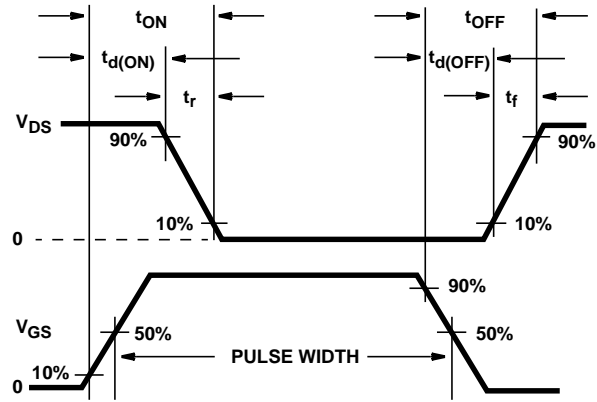

FIGURE 13. SWITCHING TIME WAVEFORM

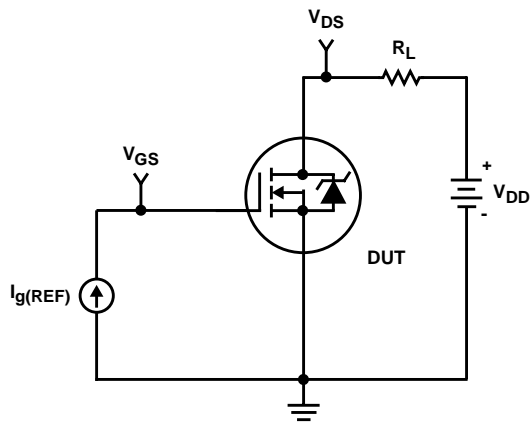

FIGURE 14. GATE CHARGE TEST CIRCUIT

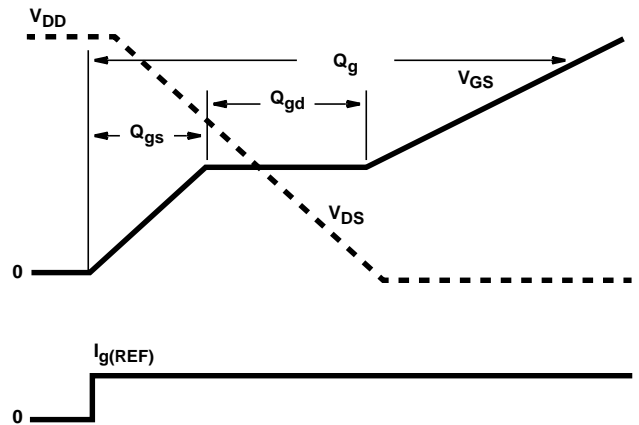

FIGURE 15. GATE CHARGE WAVEFORMS

All Intersil semiconductor products are manufactured, assembled and tested under ISO9000 quality systems certification.

Intersil semiconductor products are sold by description only. Intersil Corporation reserves the right to make changes in circuit design and/or specifications at any time without notice. Accordingly, the reader is cautioned to verify that data sheets are current before placing orders. Information furnished by Intersil is believed to be accurate and reliable. However, no responsibility is assumed by Intersil or its subsidiaries for its use; nor for any infringements of patents or other rights of third parties which may result from its use. No license is granted by implication or otherwise under any patent or patent rights of Intersil or its subsidiaries.

For information regarding Intersil Corporation and its products, see web site <http://www.intersil.com>

Sales Office Headquarters

NORTH AMERICA
 Intersil Corporation
 P. O. Box 883, Mail Stop 53-204
 Melbourne, FL 32902
 TEL: (407) 724-7000
 FAX: (407) 724-7240

EUROPE
 Intersil SA
 Mercure Center
 100, Rue de la Fusee
 1130 Brussels, Belgium
 TEL: (32) 2.724.2111
 FAX: (32) 2.724.22.05

ASIA
 Intersil (Taiwan) Ltd.
 7F-6, No. 101 Fu Hsing North Road
 Taipei, Taiwan
 Republic of China
 TEL: (886) 2 2716 9310
 FAX: (886) 2 2715 3029