

High-Voltage Ring Generator

Ordering Information

Operating Voltage	Package Options
V_{NN1}	SOW-16
-220V	HV450WG

Features

- ❑ Integrated high voltage transistors
- ❑ 67V_{RMS} ring signal
- ❑ Output over current protection
- ❑ Can drive external MOSFETs for larger loads

Applications

- ❑ High voltage ring generator
- ❑ Set-top/Street box ring generator
- ❑ Pair gain ring generator

General Description

The Supertex HV450 is a PWM high voltage ring generator. The high voltage output P- and N-channel transistors are controlled independently by the logic inputs P_{IN} and N_{IN}. For application where a single control pin (N_{IN}) is desired, the mode pin should be connected to Gnd. This adds a 200ns deadband on the control logic to avoid cross conduction on the high voltage output. A logic high on N_{IN} will turn the high voltage P-Channel on and the N-Channel off. The outputs can drive up to 5 RENS. The HV450 can drive external MOSFETs for applications requiring larger loads. The IC can be powered down by connecting the enable pin to V_{DD}. The high voltage outputs have pulse by pulse over current protection.

Pin Configuration

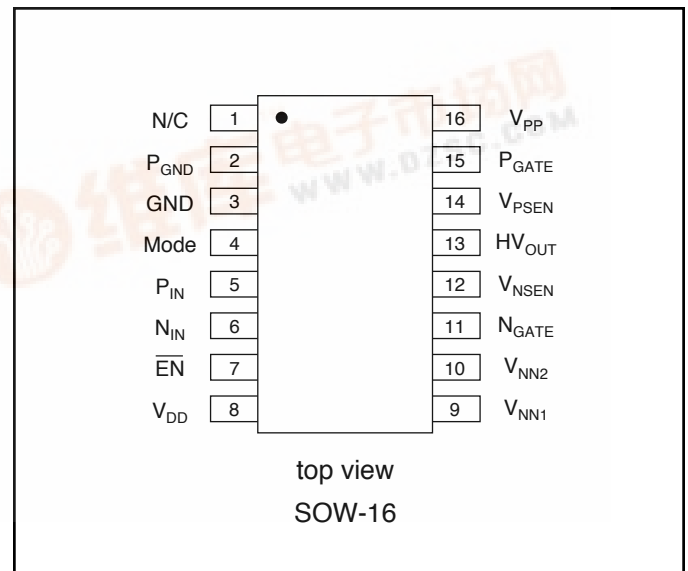

Absolute Maximum Ratings*

V_{NN1} , power supply voltage	-240V
V_{PP} , P-channel gate voltage supply	-20V
V_{NN2} , N-channel gate voltage supply	$V_{NN1}+20V$
V_{DD} , logic supply	+7.5V
Storage temperature	-65°C to +150°C
Power dissipation	600mW

*All voltages referenced to ground

Electrical Characteristics

(Over operating supply voltages unless otherwise specified, $T_A = -40^\circ\text{C}$ to $+85^\circ\text{C}$.)

Symbol	Parameters	Min	Typ	Max	Unit	Conditions
V_{PP}	P-channel linear regulator output voltage	-10		-18	V	
V_{NN1}	High voltage negative supply	- 220		-110	V	
V_{NN2}	Negative linear regulator output voltage	$V_{NN1} + 6.0$		$V_{NN1} + 10.0$	V	
V_{DD}	Logic supply voltage	4.5		5.5	V	
I_{NN1Q}	V_{NN1} quiescent current		300	500	μA	$P_{IN} = N_{IN} = \overline{EN} = L$
				25		$P_{IN} = N_{IN} = L, \overline{EN} = H$
I_{DDQ}	V_{DD1} quiescent current		90	200	μA	$P_{IN} = N_{IN} = \overline{EN} = L$
			35	100		$P_{IN} = N_{IN} = L, \overline{EN} = H$
I_{NN1}	V_{NN1} operating current		1.4		mA	No load, V_{OUTP} and V_{OUTN} switching at 100KHz
I_{DD}	V_{DD} operating current			1.0	mA	
I_{IL}	Mode logic input low current		25		μA	Mode = 0V
V_{IL}	Logic input low voltage	0		1.0	V	$V_{DD} = 5.0\text{V}$
V_{IH}	Logic input high voltage	4.0		5.0	V	$V_{DD} = 5.0\text{V}$

High Voltage Output

Symbol	Parameters	Min	Typ	Max	Unit	Conditions
R_{SOURCE}	V_{OUTP} source resistance		65		Ω	$I_{OUT} = 100\text{mA}$
R_{SINK}	V_{OUTP} sink resistance		65		Ω	$I_{OUT} = -100\text{mA}$
$t_{d(ON)}$	HV_{OUT} delay time		150		ns	$P_{IN} = \text{high to low, Mode} = \text{high}$
t_{rise}	HV_{OUT} rise time		50		ns	$P_{IN} = \text{high to low}$
$t_{d(OFF)}$	HV_{OUT} delay time		200		ns	$N_{IN} = \text{low to high, Mode} = \text{high}$
t_{fall}	HV_{OUT} fall time		50		ns	$N_{IN} = \text{low to high}$
t_{db}	Logic deadband time		250		ns	Mode = low
V_{psen}	HV_{OUT} current source sense voltage	-1.2		-0.8	V	
V_{nsen}	HV_{OUT} current sink sense voltage	$V_{NN1} + 0.8$		$V_{NN1} + 1.2$	V	
t_{shortP}	HV_{OUT} off delay time when current source sense is activated		70	150	ns	
t_{shortN}	HV_{OUT} off delay time when current sink sense is activated		70	150	ns	
t_{whout}	Minimum pulse width for HV_{OUT} at P_{GND}			500	ns	
t_{wlout}	Minimum pulse width for HV_{OUT} at V_{NN1}			500	ns	

Truth Table

N_{IN}	P_{IN}	Mode	\overline{EN}	HV_{OUT}
L	L	H	L	Pgnd
L	H	H	L	High Z
H*	L*	H	L	*
H	H	H	L	V_{NN1}
L	X	L	L	V_{NN1}
H	X	L	L	Pgnd
X	X	X	H	High Z

*This state will short V_{NN1} to Pgnd and should therefore be avoided.

Block Diagram

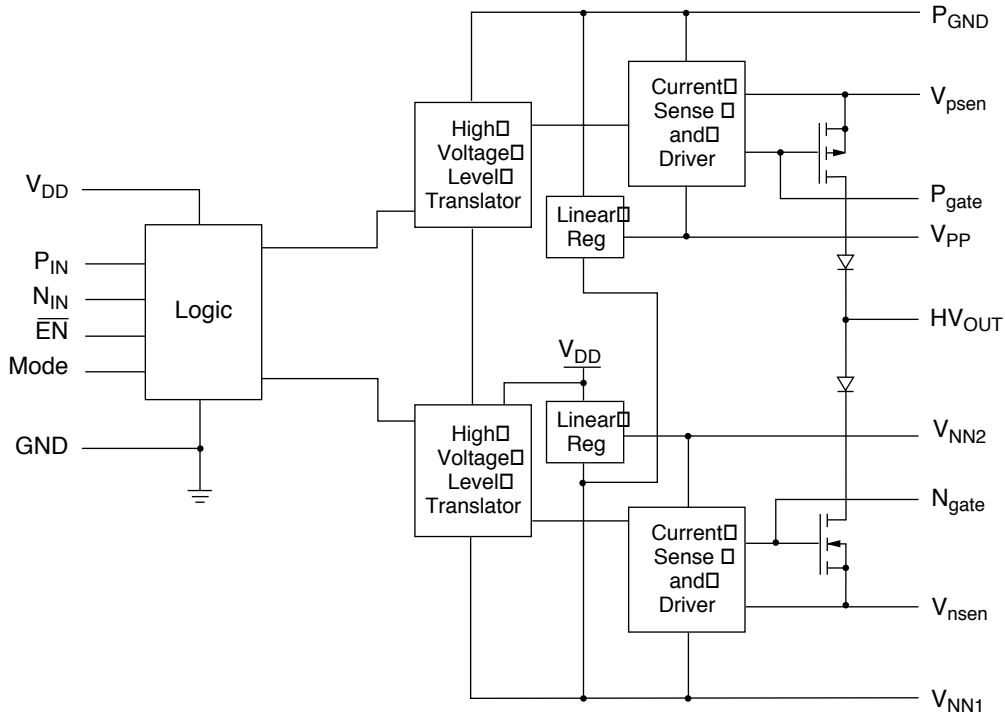

Pin Description

V _{PP}	P-channel gate voltage supply. Generated by an internal linear regulator. A 0.1µF capacitor should be connected between P _{GND} and V _{PP} .
V _{NN1}	Negative high voltage supply.
V _{NN2}	N-channel gate voltage supply. Generated by an internal linear regulator. A 0.1µF capacitor should be connected between V _{NN2} and V _{NN1} .
V _{DD}	Logic supply voltage.
GND	Low voltage ground.
P _{GND}	High voltage power ground.
P _{IN}	Logic control input. When mode is high, logic input high turns OFF output high voltage P-Channel.
N _{IN}	Logic control input. When mode is high, logic input high turns ON output high voltage N-Channel.
EN	Logic enable input. Logic low enables IC.
Mode	Logic mode input. Logic low activates 200nsec deadband. When mode is low, N _{IN} turns on and off the high voltage N- and P-Channels. Pin is not used and should be connected to V _{DD} or ground.
HV _{OUT}	High voltage output. Voltage swings from P _{GND} to V _{NN1} .
V _{psen}	Pulse by pulse over current sensing for P-Channel MOSFET.
V _{nsen}	Pulse by pulse over current sensing for N-Channel MOSFET.
P _{gate}	Gate drive for external P-channel MOSFET.
N _{gate}	Gate drive for external N-channel MOSFET.

