

Supertex inc.

HV823

High Voltage EL Lamp Driver

Ordering Information

| Device | Input Voltage | Package Options | |
|--------|---------------|-----------------|--------|
| | | 8-Lead SO | Die |
| HV823 | 2.0V to 9.5V | HV823LG | HV823X |

Features

- Processed with HVC MOS[®] technology
- 2.0V to 9.5V operating supply voltage
- DC to AC conversion
- 180V peak-to-peak typical output voltage
- Large output load capability typically 50nF
- Permits the use of high-resistance elastomeric lamp components
- Adjustable output lamp frequency to control lamp color, lamp life, and power consumption
- Adjustable converter frequency to eliminate harmonics and optimize power consumption
- Enable/disable function
- Low current draw under no load condition

Applications

- Handheld personal computers
- Electronic personal organizers
- GPS units
- Pagers
- Cellular phones
- Portable instrumentation

Absolute Maximum Ratings*

| | |
|-----------------------------|-----------------|
| Supply Voltage, V_{DD} | -0.5V to +10V |
| Output Voltage, V_{CS} | -0.5V to +120V |
| Operating Temperature Range | -25°C to +85°C |
| Storage Temperature Range | -65°C to +150°C |
| Power Dissipation | 400mW |

Note:
All voltages are referenced to GND.

General Description

The Supertex HV823 is a high-voltage driver designed for driving EL lamps of up to 50nF. EL lamps greater than 50nF can be driven for applications not requiring high brightness. The input supply voltage range is from 2.0 to 9.5V. The device uses a single inductor and a minimum number of passive components. The nominal regulated output voltage that is applied to the EL lamp is $\pm 90V$. The chip can be enabled by connecting the resistors on R_{SW-osc} and R_{EL-osc} to V_{DD} and disabled when connected to GND.

The HV823 has two internal oscillators, a switching MOSFET, and a high-voltage EL lamp driver. The frequency for the switching converter MOSFET is set by an external resistor connected between the R_{SW-osc} pin and the supply pin V_{DD} . The EL lamp driver frequency is set by an external resistor connected between R_{EL-osc} pin and the V_{DD} pin. An external inductor is connected between the L_x and V_{DD} pins. A 0.01 μF to 0.1 μF capacitor is connected between C_s and GND. The EL lamp is connected between V_A and V_B .

The switching MOSFET charges the external inductor and discharges it into the C_s capacitor. The voltage at C_s will start to increase. Once the voltage at C_s reaches a nominal value of 90V, the switching MOSFET is turned OFF to conserve power. The outputs V_A and V_B are configured as an H-bridge and are switched in opposite states to achieve 180V peak-to-peak across the EL lamp.

Pin Configuration

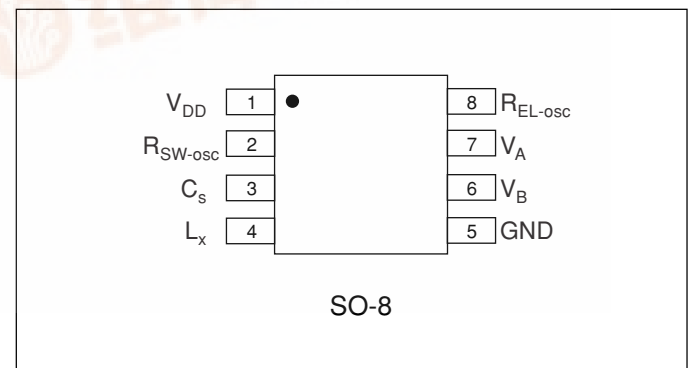

Electrical Characteristics

DC Characteristics ($V_{IN} = 3.0V$, $R_{SW} = 750K\Omega$, $R_{EL} = 2.0M\Omega$, $T_A = 25^\circ C$ unless otherwise specified)

| Symbol | Parameter | Min | Typ | Max | Units | Conditions |
|--------------|---|-----|-----|-----|----------|---------------------------------|
| $R_{DS(on)}$ | On-resistance of switching transistor | | 2 | 6 | Ω | $I = 100mA$ |
| V_{CS} | Output voltage V_{CS} Regulation | 80 | 90 | 100 | V | $V_{IN} = 2.0$ to $9.5V$ |
| $V_A - V_B$ | Output peak to peak voltage | 160 | 180 | 200 | V | $V_{IN} = 2.0V$ to $9.5V$ |
| I_{DDQ} | Quiescent V_{DD} supply current, disabled | | 30 | 100 | nA | $R_{SW-osc} = Low$ |
| I_{DD} | Input current going into the V_{DD} pin | | 150 | 200 | μA | $V_{IN} = 3.0V$. See Figure 1. |
| | | | | 300 | μA | $V_{IN} = 5.0V$. See Figure 2. |
| | | | | 500 | μA | $V_{IN} = 9.0V$. See Figure 3. |
| I_{IN} | Input current including inductor current | | 25 | 33 | mA | $V_{IN} = 3.0V$. See Figure 1. |
| V_{CS} | Output voltage on V_{CS} | 60 | 70 | 85 | V | $V_{IN} = 3.0V$. See Figure 1. |
| f_{EL} | V_{A-B} output drive frequency | 330 | 380 | 450 | Hz | $V_{IN} = 3.0V$. See Figure 1. |
| f_{SW} | Switching transistor frequency | 50 | 60 | 70 | KHz | $V_{IN} = 3.0V$. See Figure 1. |
| D | Switching transistor duty cycle | | 88 | | % | |

Recommended Operating Conditions

| Symbol | Parameter | Min | Typ | Max | Units | Conditions |
|----------|-----------------------|-----|-----|-----|------------|------------|
| V_{DD} | Supply voltage | 2.0 | | 9.5 | V | |
| T_A | Operating temperature | -25 | | +85 | $^\circ C$ | |

Enable/Disable Table (See Figure 4)

| R_{SW} resistor | HV823 |
|-------------------|---------|
| V_{DD} | Enable |
| 0V | Disable |

Block Diagram

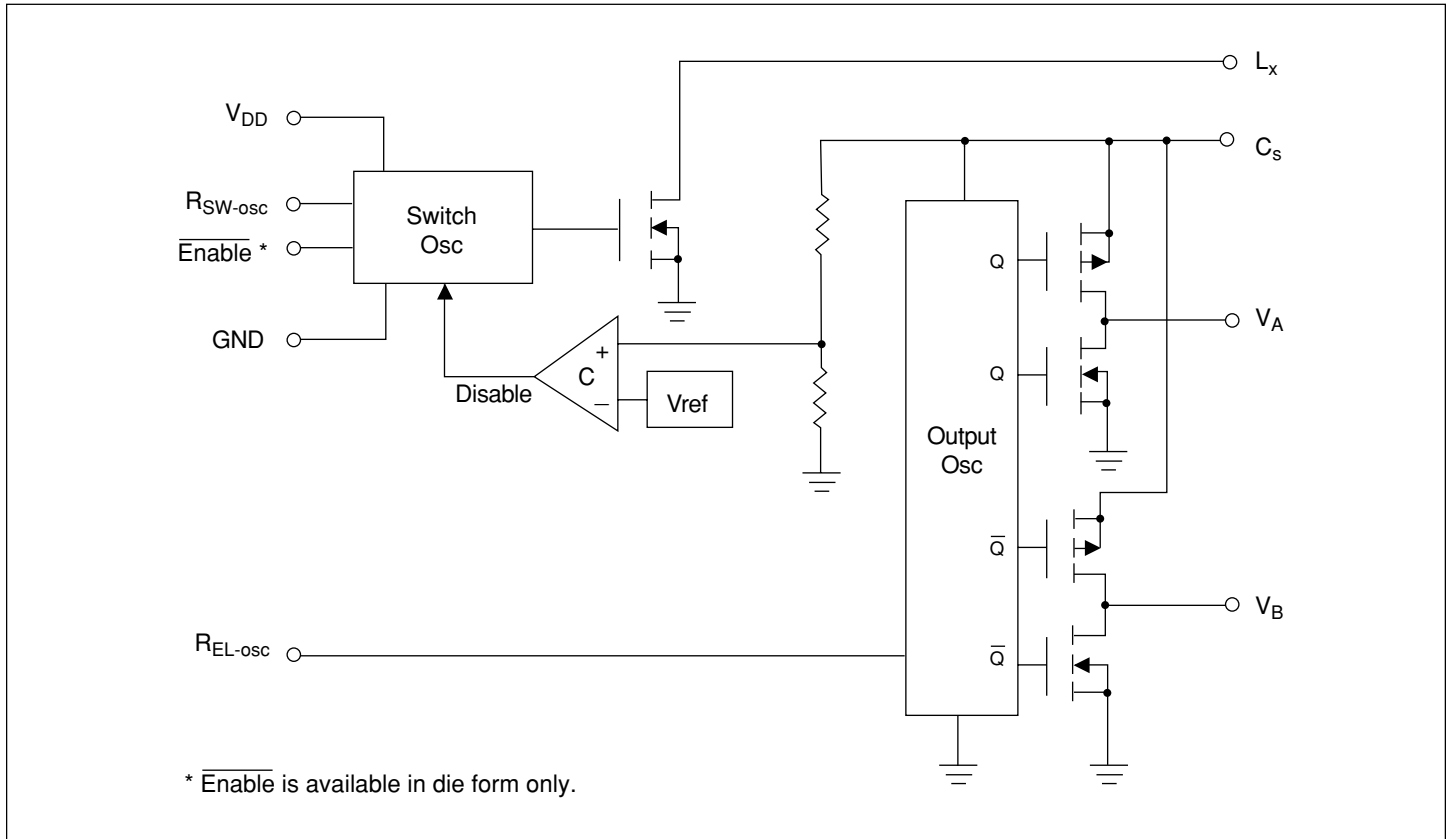
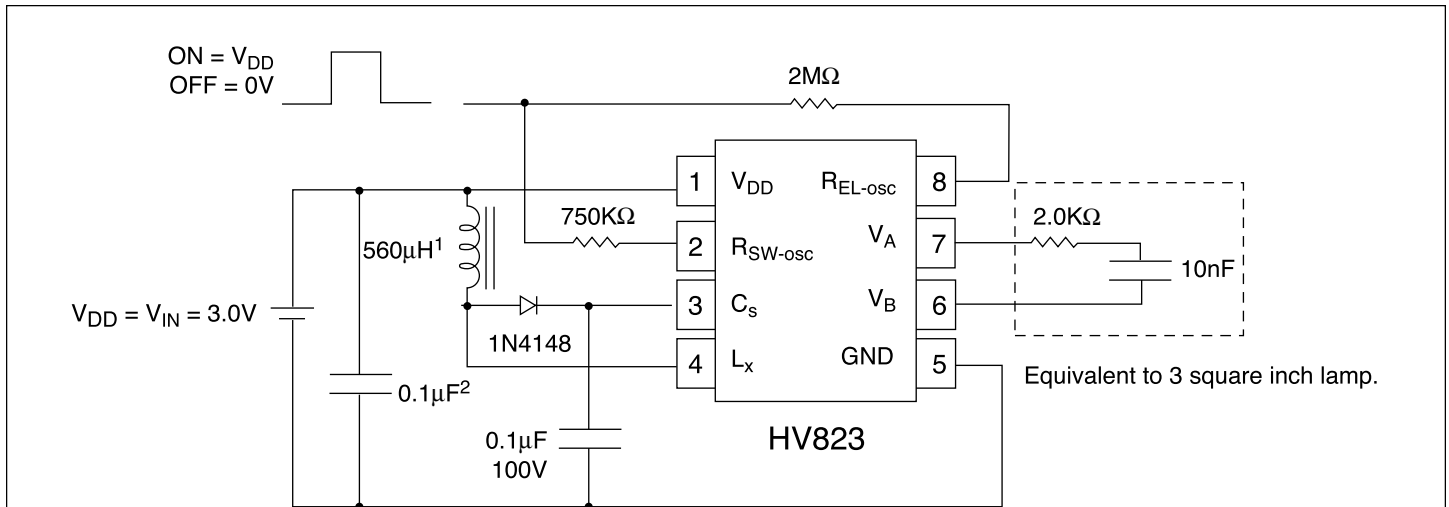

Figure 1: Test Circuit, $V_{IN} = 3.0V$ (Low input current with moderate output brightness).



Typical Performance

| Lamp Size | V_{IN} | I_{IN} | V_{CS} | f_{EL} | Brightness |
|---------------------|----------|----------|----------|----------|------------|
| 3.0 in ² | 3.0v | 25mA | 65v | 385Hz | 6.5ft-lm |

Notes:

- Murata part # LQH4N561K04 (DC resistance < 14.5Ω)
- Larger values may be required depending upon supply impedance.

Typical Performance Curves for Figure 1 using 3in² EL Lamp.

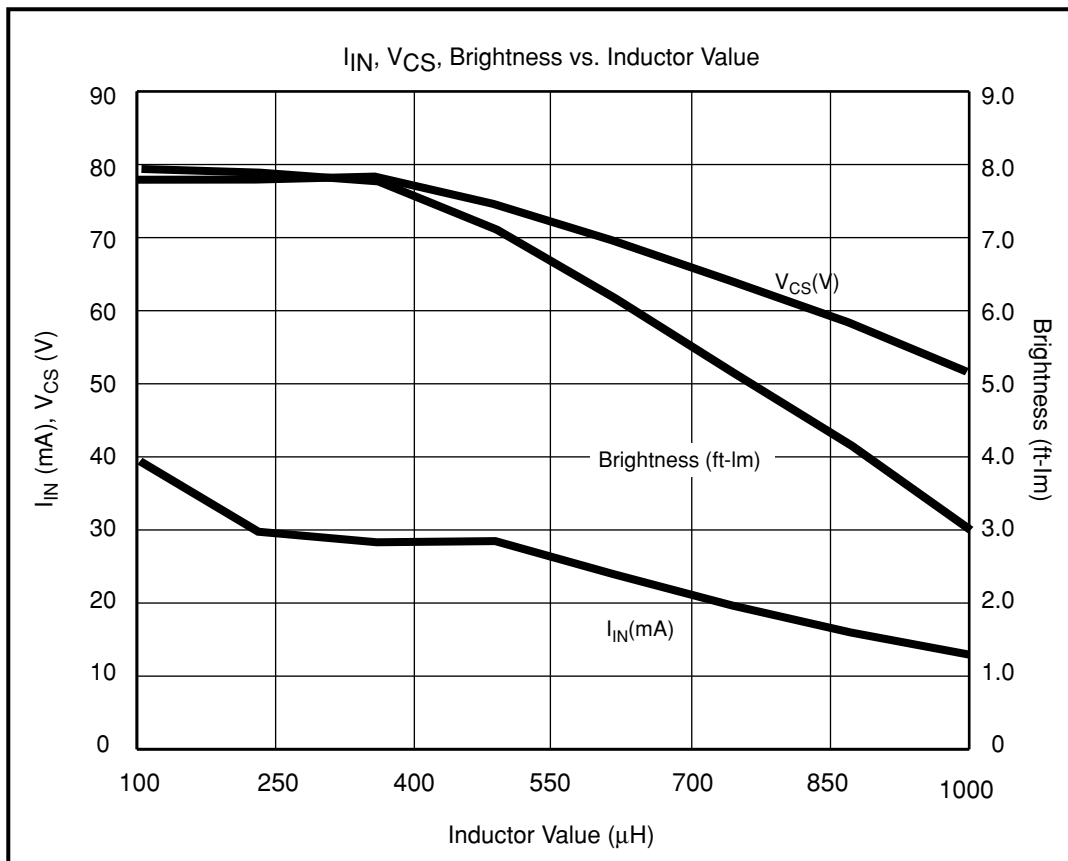
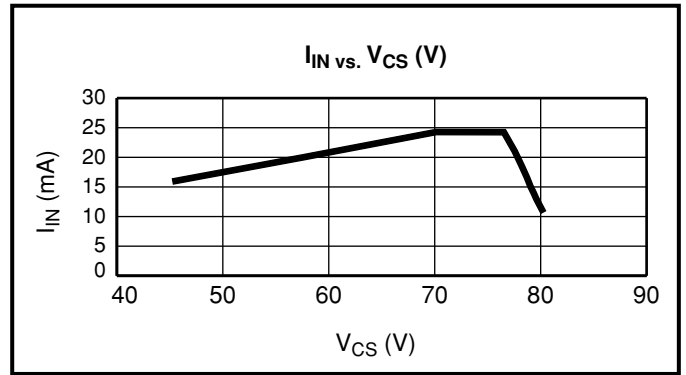
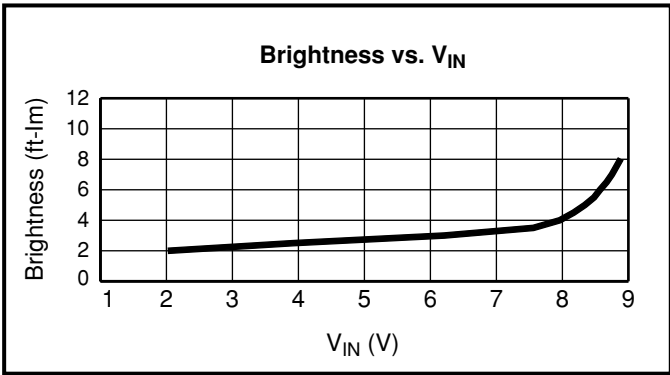
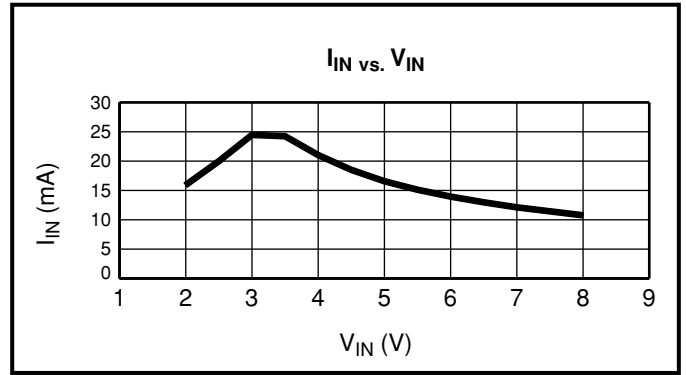
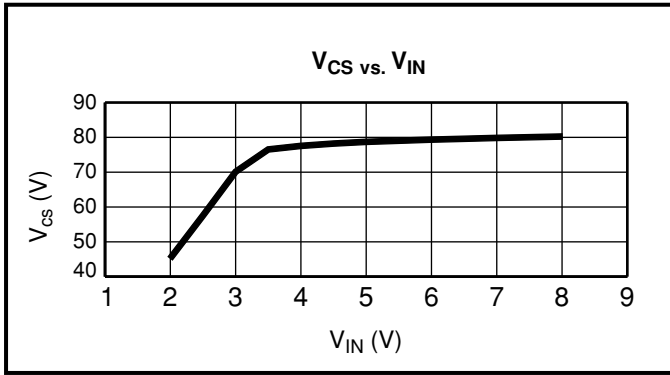
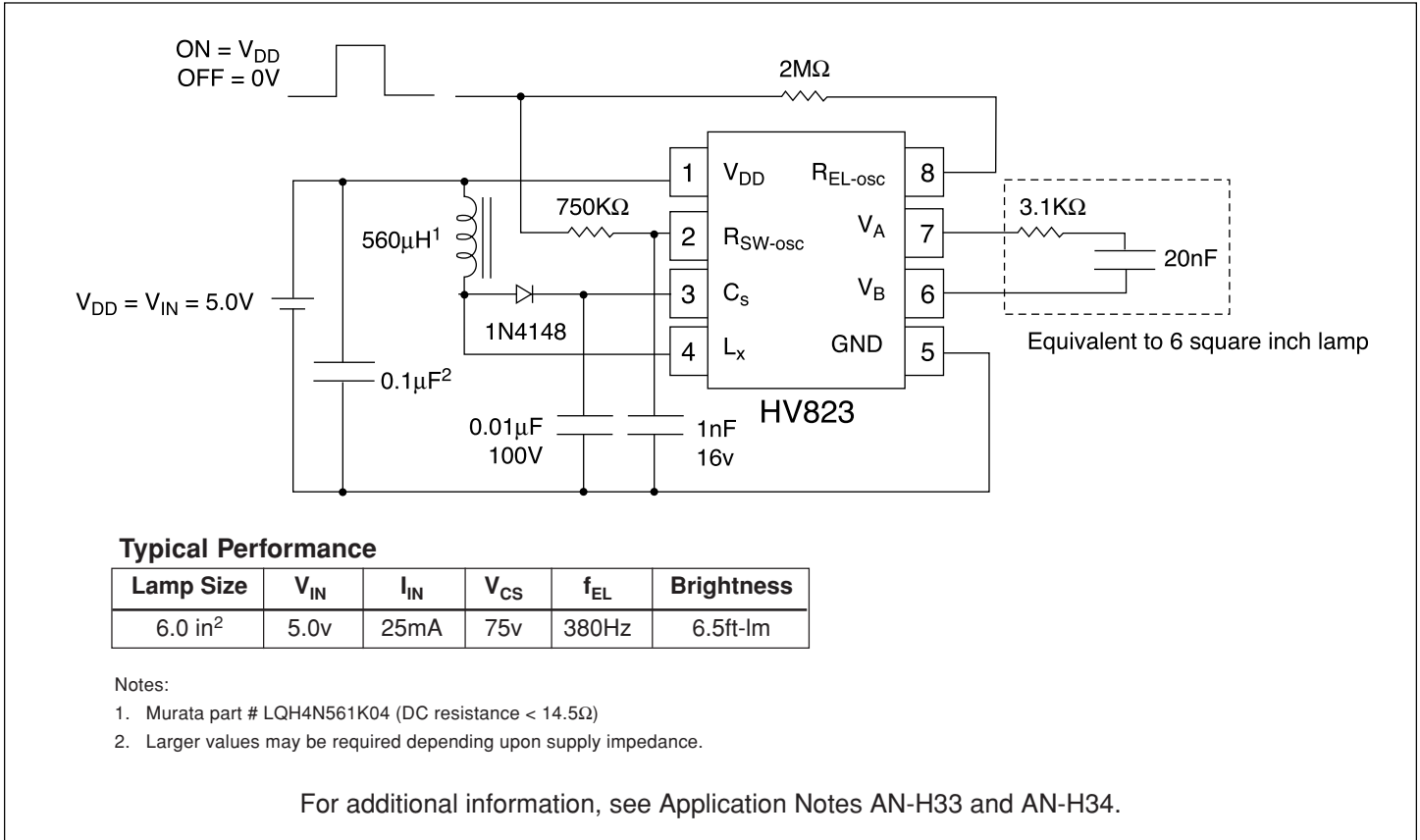

Figure 2: Typical 5.0V Application



Typical Performance Curves for Figure 2

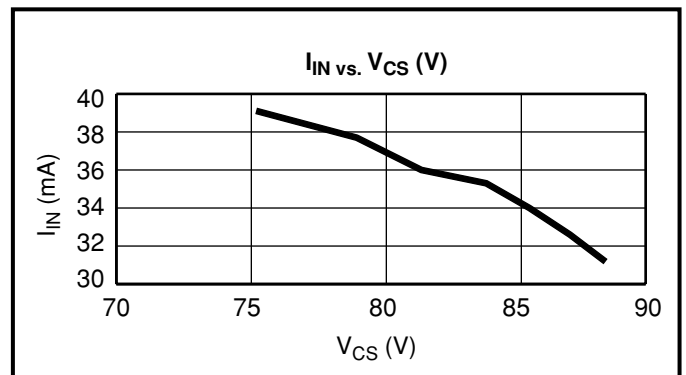
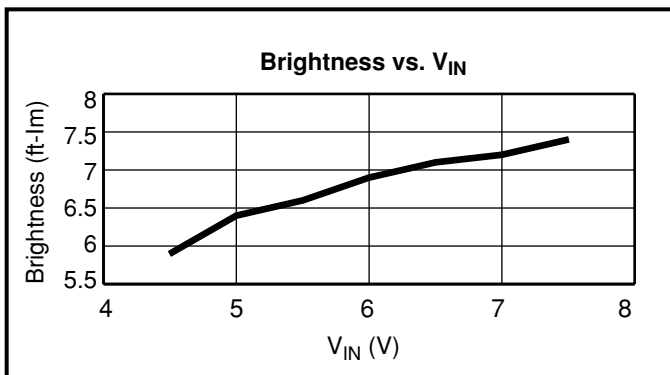
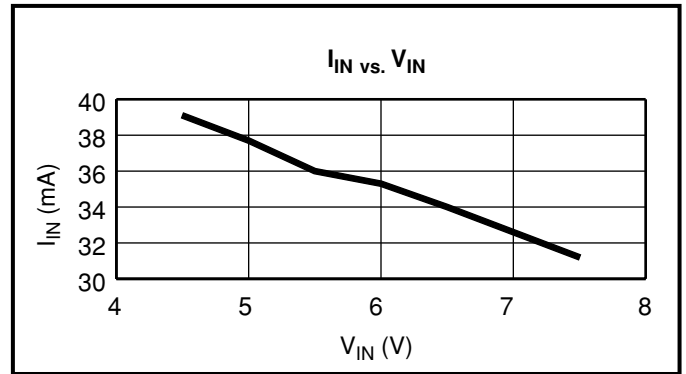
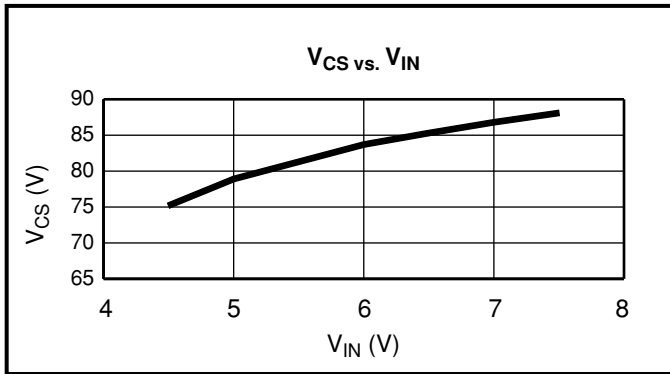
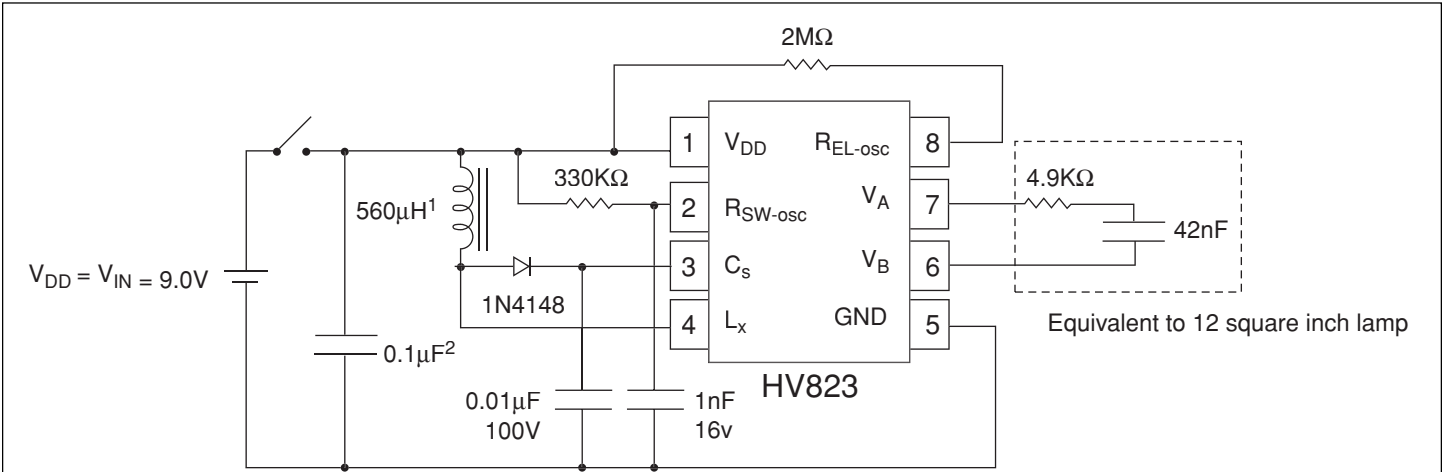

Figure 3: Typical 9.0V Application*



Typical Performance

| Lamp Size | V _{IN} | I _{IN} | V _{CS} | f _{EL} | Brightness |
|----------------------|-----------------|-----------------|-----------------|-----------------|------------|
| 12.0 in ² | 9.0v | 30mA | 75v | 380Hz | 8.5ft-lm |

Notes:

1. Murata part # LQH4N561K04 (DC resistance < 14.5Ω)
2. Larger values may be required depending upon supply impedance.

For additional information, see Application Notes AN-H33 and AN-H34.

Typical Performance Curves for Figure 3

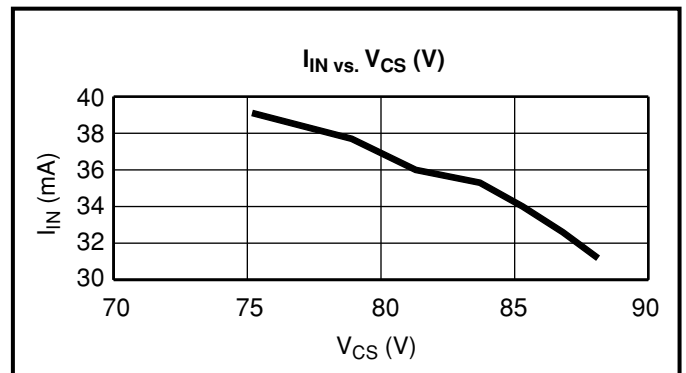
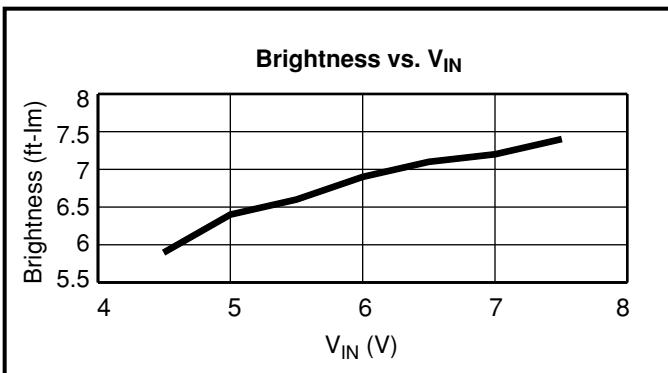
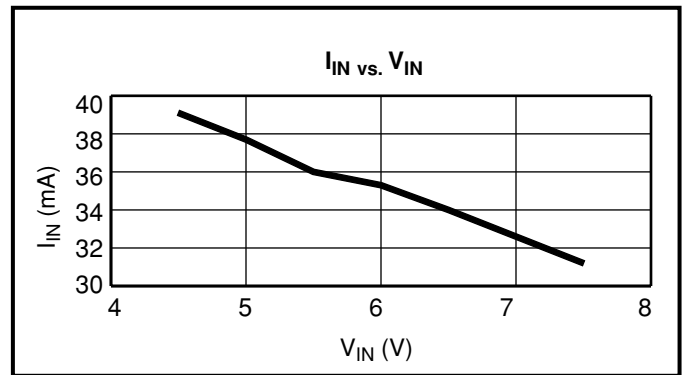
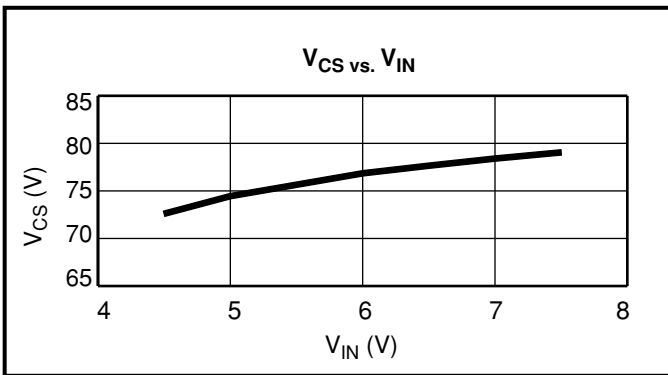

External Component Description

| External Component | Selection Guide Line |
|---------------------------|---|
| Diode | Fast reverse recovery diode, 1N4148 or equivalent. |
| C _S Capacitor | 0.01μF to 0.1μF, 100V capacitor to GND is used to store the energy transferred from the inductor. |
| R _{EL-osc} | The EL lamp frequency is controlled via an external R _{EL} resistor connected between R _{EL-osc} and V _{DD} of the device. The lamp frequency increases as R _{EL} decreases. As the EL lamp frequency increases, the amount of current drawn from the battery will increase and the output voltage V _{CS} will decrease. The color of the EL lamp is dependent upon its frequency. A 2MΩ resistor would provide lamp frequency of 330 to 450Hz. Decreasing the R _{EL-osc} by a factor of 2 will increase the lamp frequency by a factor of 2. |
| R _{SW-osc} | The switching frequency of the converter is controlled via an external resistor, R _{SW} between R _{SW-osc} and V _{DD} of the device. The switching frequency increases as R _{SW} decreases. With a given inductor, as the switching frequency increases, the amount of current drawn from the battery will decrease and the output voltage, V _{CS} , will also decrease. |
| C _{SW} Capacitor | A 1nF capacitor is recommended on R _{SW-osc} to GND when a 0.01μF C _S capacitor is used. This capacitor is used to shunt any switching noise that may couple into the R _{SW-osc} pin. The C _{SW} capacitor may also be needed when driving large EL lamp due to increase in switching noise. |
| L _x Inductor | The inductor L _x is used to boost the low input voltage by inductive flyback. When the internal switch is on, the inductor is being charged. When the internal switch is off, the charge stored in the inductor will be transferred to the high voltage capacitor C _S . The energy stored in the capacitor is connected to the internal H-bridge and therefore to the EL lamp. In general, smaller value inductors, which can handle more current, are more suitable to drive larger size lamps. As the inductor value decreases, the switching frequency of the inductor (controlled by R _{SW}) should be increased to avoid saturation. 560μH Murata inductors with 14.5Ω series DC resistance is typically recommended. For inductors with the same inductance value but with lower series DC resistance, lower R _{SW} value is needed to prevent high current draw and inductor saturation. |
| Lamp | As the EL lamp size increases, more current will be drawn from the battery to maintain high voltage across the EL lamp. The input power, (V _{IN} × I _{IN}), will also increase. If the input power is greater than the power dissipation of the package (400mW), an external resistor in series with one side of the lamp is recommended to help reduce the package power dissipation. |

Enable/Disable Configuration

The HV823 can be easily enabled and disabled via a logic control signal on the R_{SW} and R_{EL} resistors as shown in Figure 4 below. The control signal can be from a microprocessor. R_{SW} and R_{EL} are typically very high values. Therefore, only 10's of microam-

peres will be drawn from the logic signal when it is at a logic high (enable) state. When the microprocessor signal is high the device is enabled and when the signal is low, it is disabled.

Figure 4: Enable/Disable Configuration

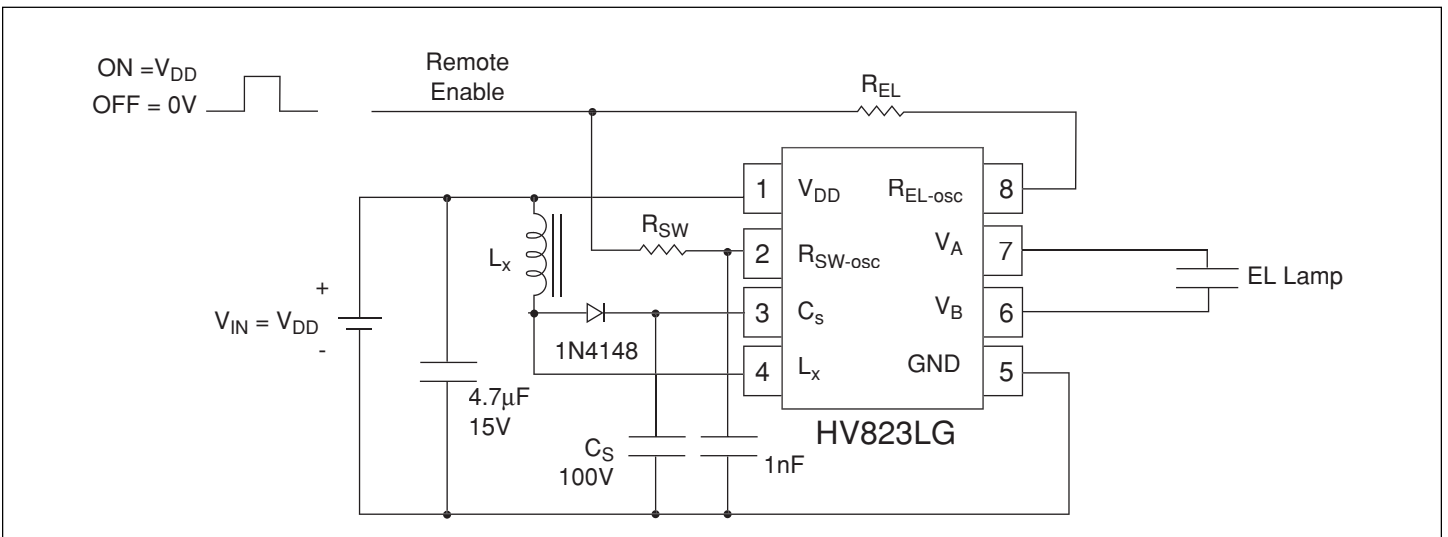

Split Supply Configuration Using a Single Cell (1.5V) Battery

The HV823 can also be used for handheld devices operating from a single cell 1.5V battery where a regulated voltage is available. This is shown in Figure 5. The regulated voltage can be used to run the internal logic of the HV823. The amount of current necessary to run the internal logic is typically 100µA at a V_{DD} of 3.0V. Therefore, the regulated voltage could easily provide the current without being loaded down. The HV823 used in this configuration can also be enabled/disabled via logic control signal on the R_{SW} and R_{EL} resistors as shown in Figure 4.

Split Supply Configuration for Battery Voltages of Higher than 9.5V

Figure 5 can also be used with high battery voltages such as 12V as long as the input voltage, V_{DD} , to the HV823 device is within its specifications of 2.0V to 9.5V.

Figure 5: Split Supply Configuration

