



High Voltage EL Lamp Driver

Features

- ❑ 1.8V to 6.5V operating supply voltage
- ❑ DC to AC conversion
- ❑ Separately adjustable lamp and converter frequency
- ❑ Output voltage regulation
- ❑ Enable/disable function
- ❑ Patented output timing for high efficiency
- ❑ <100nA shutdown current
- ❑ Split supply capability
- ❑ LCD backlighting

Applications

- ❑ Portable Transceivers
- ❑ Remote Control Units
- ❑ Calculators
- ❑ PDAs
- ❑ Global Positioning Systems (GPS)

General Description

The Supertex HV833 is a high voltage driver designed for driving EL lamps of up to 35nF (10-12in²). The input supply voltage range is from 1.8V to 6.5V. The device uses a single inductor and a minimum number of passive components. The nominal regulated output voltage that is applied to the EL lamp is ±90V. The chip can be enabled/disabled by connecting the resistor on R_{SW-osc} to V_{DD}/ground.

The HV833 has two internal oscillators, a switching MOSFET, and a high voltage EL lamp driver. The frequency for the switching MOSFET is set by an external resistor connected between the R_{SW-osc} pin and the supply pin V_{DD}. The EL lamp driver frequency is set by an external resistor connected between R_{EL-osc} pin and the V_{DD} pin. An external inductor is connected between the L_x and V_{DD} or V_{IN} pins. A 0.003-0.1μF capacitor is connected between C_s and ground. The EL lamp is connected between V_A and V_B.

The switching MOSFET charges the external inductor and discharges it into the capacitor at C_s. The voltage at C_s will start to increase. Once the voltage at C_s reaches a nominal value of 90V, the switching MOSFET is turned OFF to conserve power. The outputs V_A and V_B are configured as an H bridge and are switching in opposite states to achieve 180V peak-to-peak across the EL lamp.

Typical Application

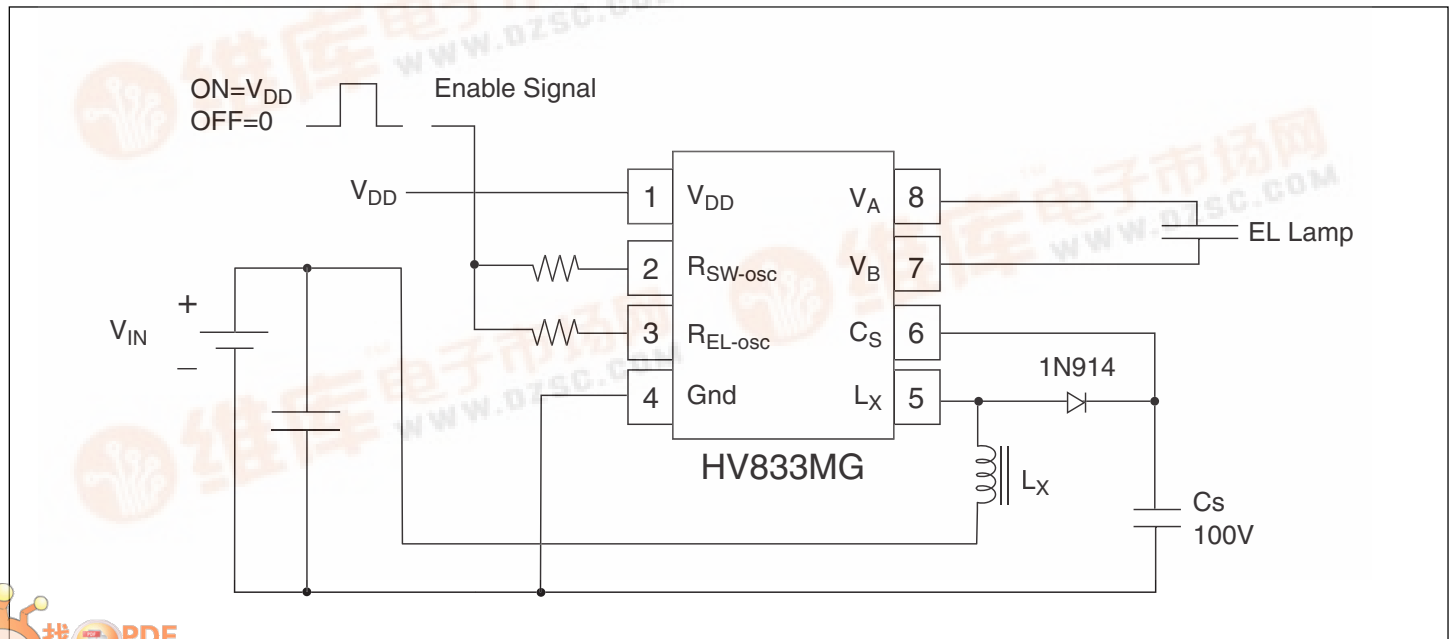

Ordering Information

Device	Package Options	
	MSOP-8	Die
HV833	HV833MG*	HV833X

* Product supplied on 2500 piece carrier tape reels.

Absolute Maximum Ratings*

Supply Voltage, V_{DD}	-0.5V to +7.5V
Output Voltage, V_{CS}	-0.5V to +100V
Operating Temperature Range	-25° to +85°C
Storage Temperature Range	-65°C to +150°C
MSOP-8 Power Dissipation	300mW

Note:

*All voltages are referenced to GND.

Pin Configuration

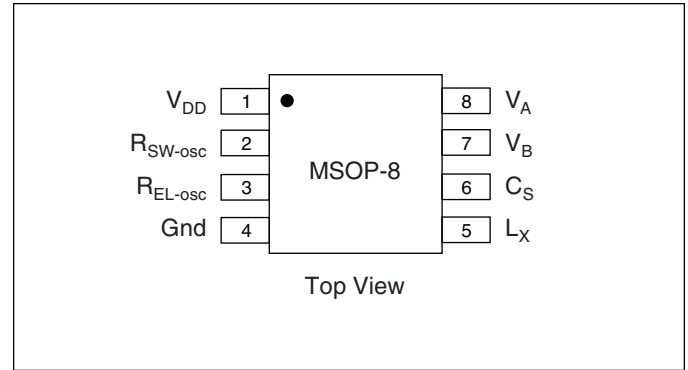

Enable/Disable Table

(See Typical Application on Front Page)

R_{SW} resistor	HV833
V_{DD}	Enable
0V	Disable

Electrical Characteristics

DC Characteristics (Over recommended operating conditions unless otherwise specified, $T_A=25^\circ\text{C}$)

Symbol	Parameter	Min	Typ	Max	Units	Conditions
$R_{DS(on)}$	On-resistance of switching transistor			4.0	Ω	$I=100\text{mA}$
V_{CS}	Max. output regulation voltage	80	90	100	V	$V_{DD}=1.8\text{V to }6.5\text{V}$
V_{A-B}	Max. of differential output voltage across lamp	160	180	200	V	$V_{DD}=1.8\text{V to }6.5\text{V}$
I_{DDQ}	Quiescent V_{DD} supply current			100	nA	$R_{SW-osc} = \text{Low}$
I_{DD}	Input current going into the V_{DD} pin			150	μA	$V_{DD}=1.8\text{V to }6.5\text{V}$. See Figure 1.
I_{IN}	Input current including inductor current		56	64	mA	$V_{IN}=3.3\text{V}$. See Figure 1.
V_{CS}	Output voltage on V_{CS}	63	72	81	V	$V_{IN}=3.3\text{V}$. See Figure 1.
f_{EL}	V_{A-B} output drive frequency	240	270	300	Hz	$V_{IN}=3.3\text{V}$. See Figure 1.
f_{SW}	Switching transistor frequency	55	65	75	KHz	$V_{IN}=3.3\text{V}$. See Figure 1.
D	Switching transistor duty cycle		88		%	See figure 1.

Recommended Operating Conditions

Symbol	Parameter	Min	Typ	Max	Units	Conditions
V_{DD}	Supply voltage	1.8		6.5	V	
f_{EL}	V_{A-B} output drive frequency	60		1000	Hz	
T_A	Operating temperature	-25		85	$^\circ\text{C}$	

Enable/Disable Function Table

Symbol	Parameter	Min	Typ	Max	Units	Conditions
EN-L	Logic input low voltage	0		0.5	V	$V_{DD}=1.8\text{V to }6.5\text{V}$
EN-H	Logic input high voltage	$V_{DD}-0.5$		V_{DD}	V	$V_{DD}=1.8\text{V to }6.5\text{V}$

Block Diagram

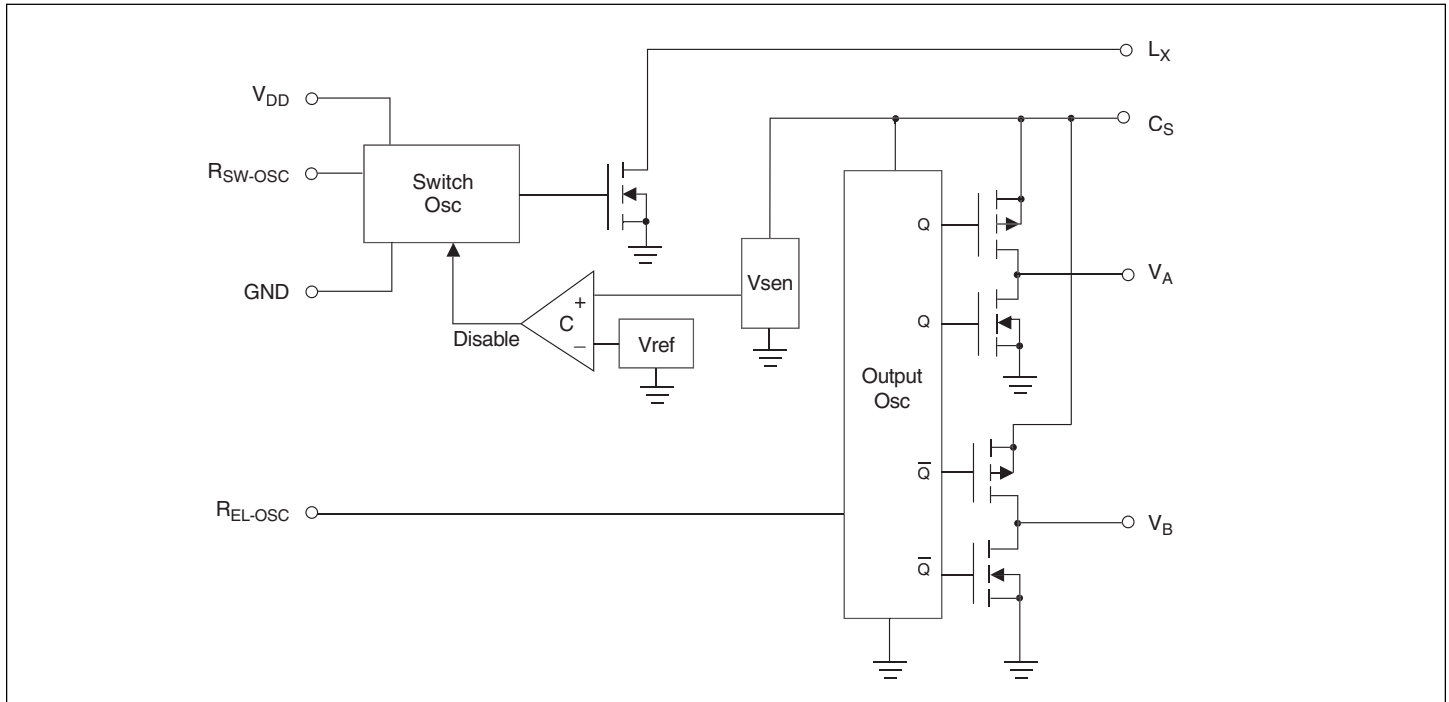
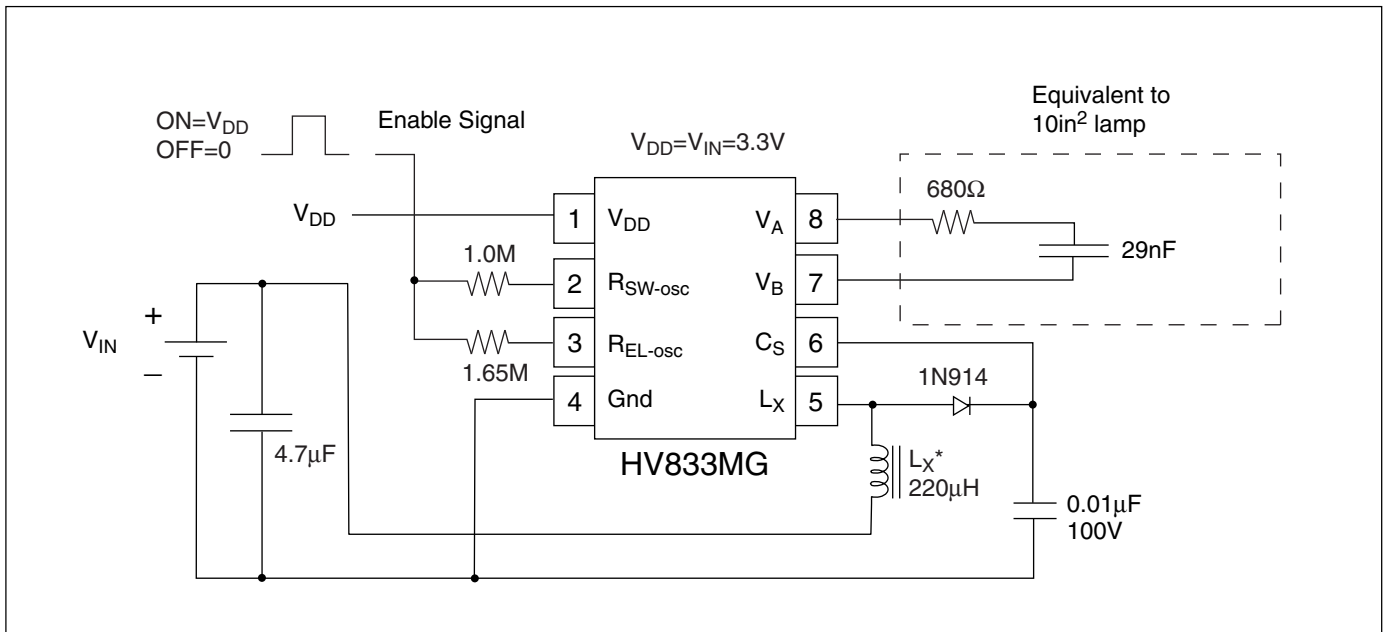

Figure 1: Typical Application



* Lx = 220µH Murata LQH43MN221K01

Typical Performance

Device	Lamp Size	V _{IN}	I _{IN}	V _{CS}	f _{EL}	Brightness	T _A
HV833MG	10 in ²	3.3V	56mA	72V	270Hz	5.0ft-lm	-25°C to +85°C

Typical Performance Curves for Figure 1 (EL Lamp= 10.0 in², V_{IN}=V_{DD}).

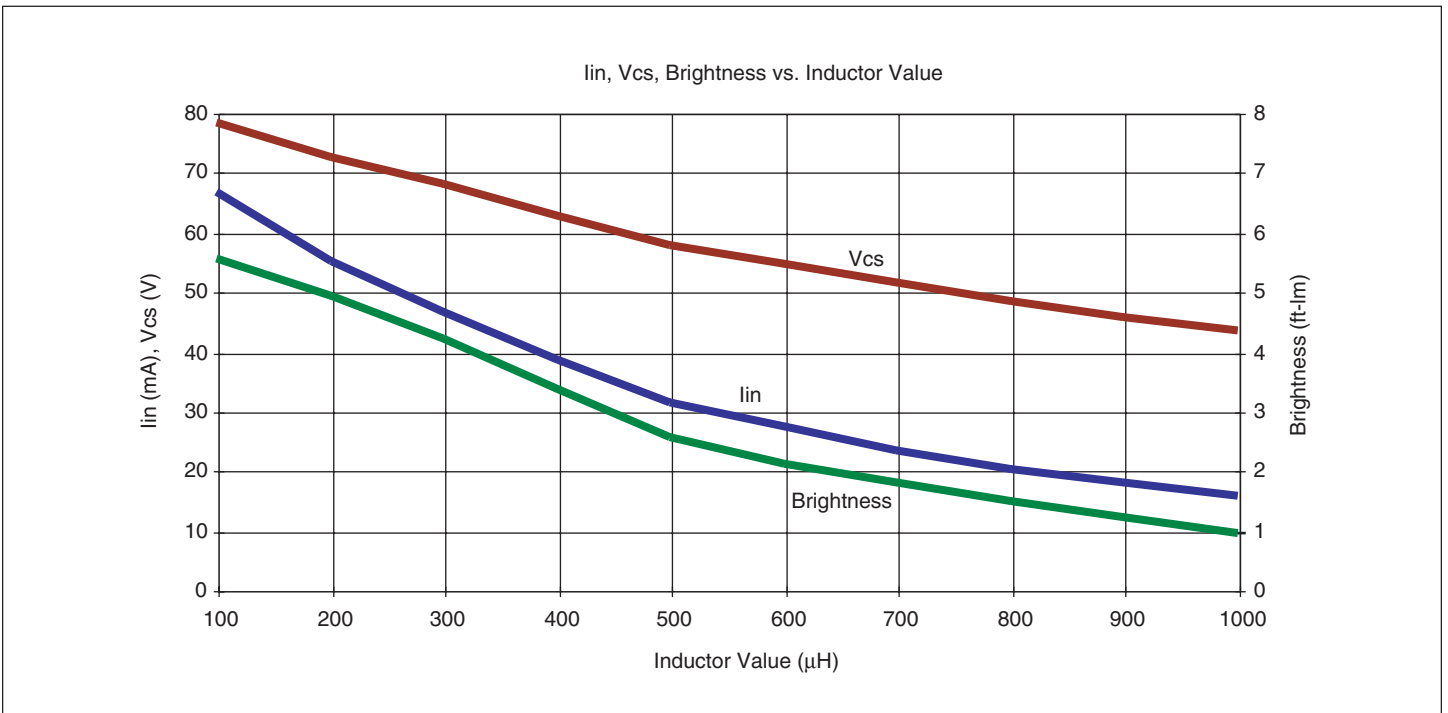
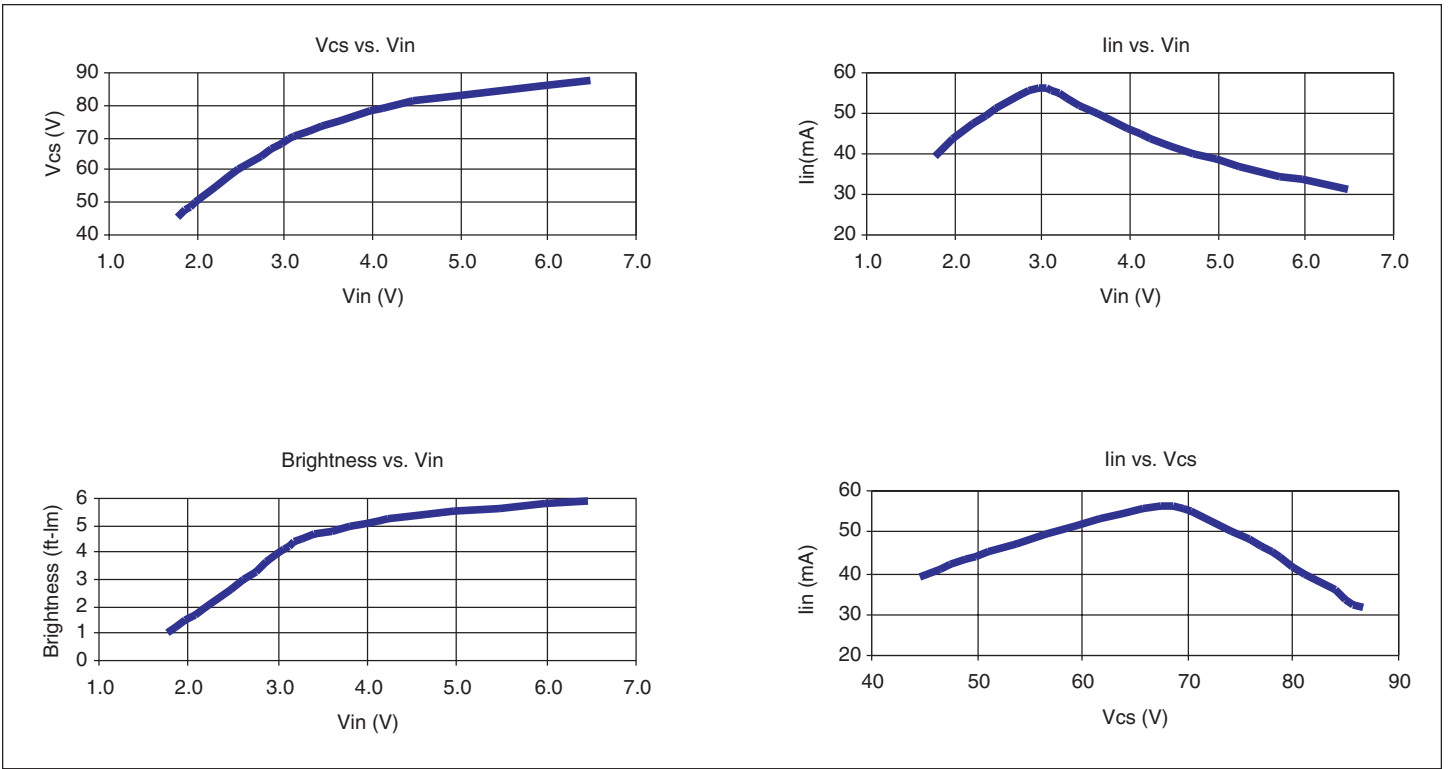
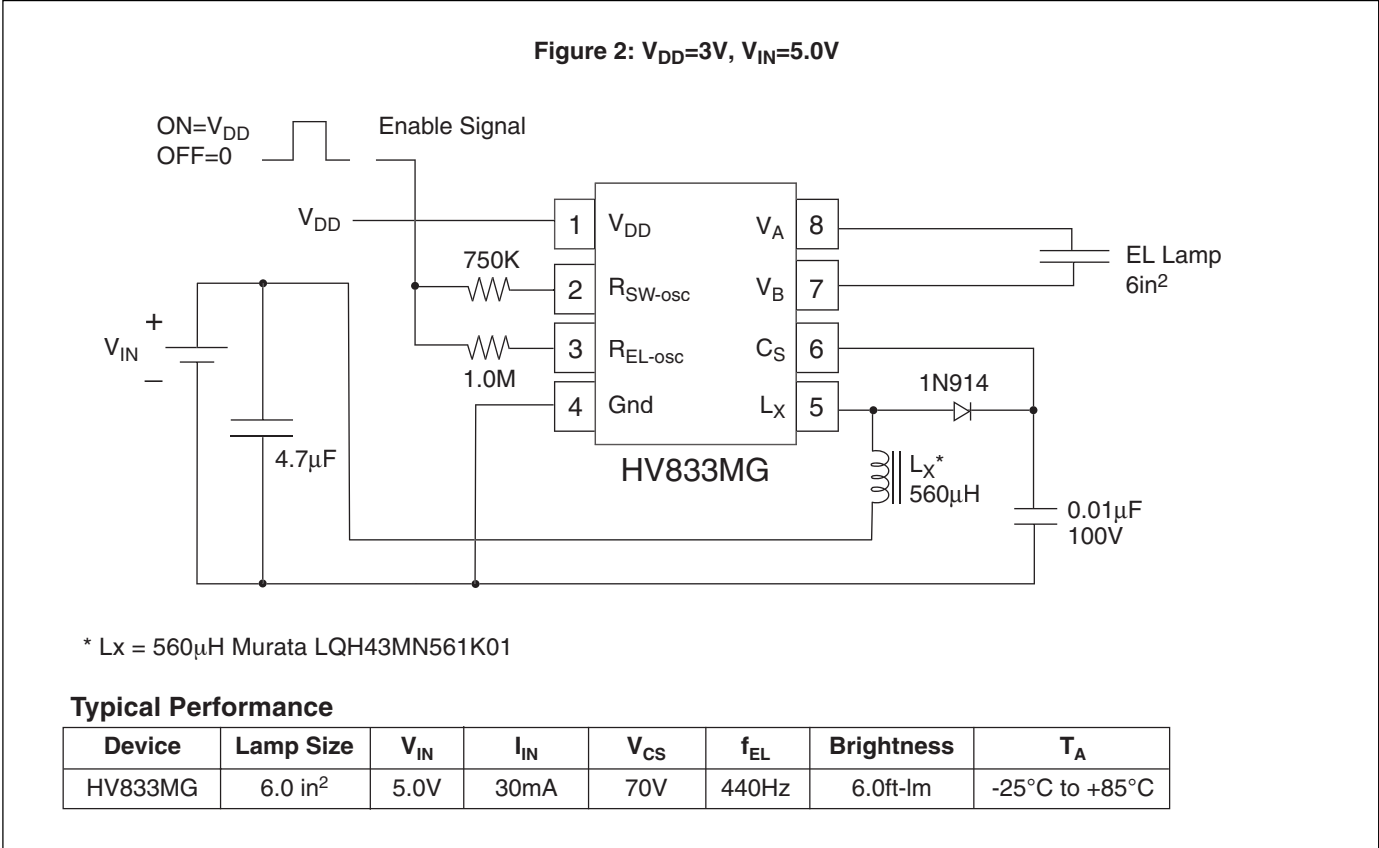

Figure 2: Typical Application



Typical Performance Curves for Figure 2 (EL Lamp= 6.0 in², V_{DDκ}=3.0V).

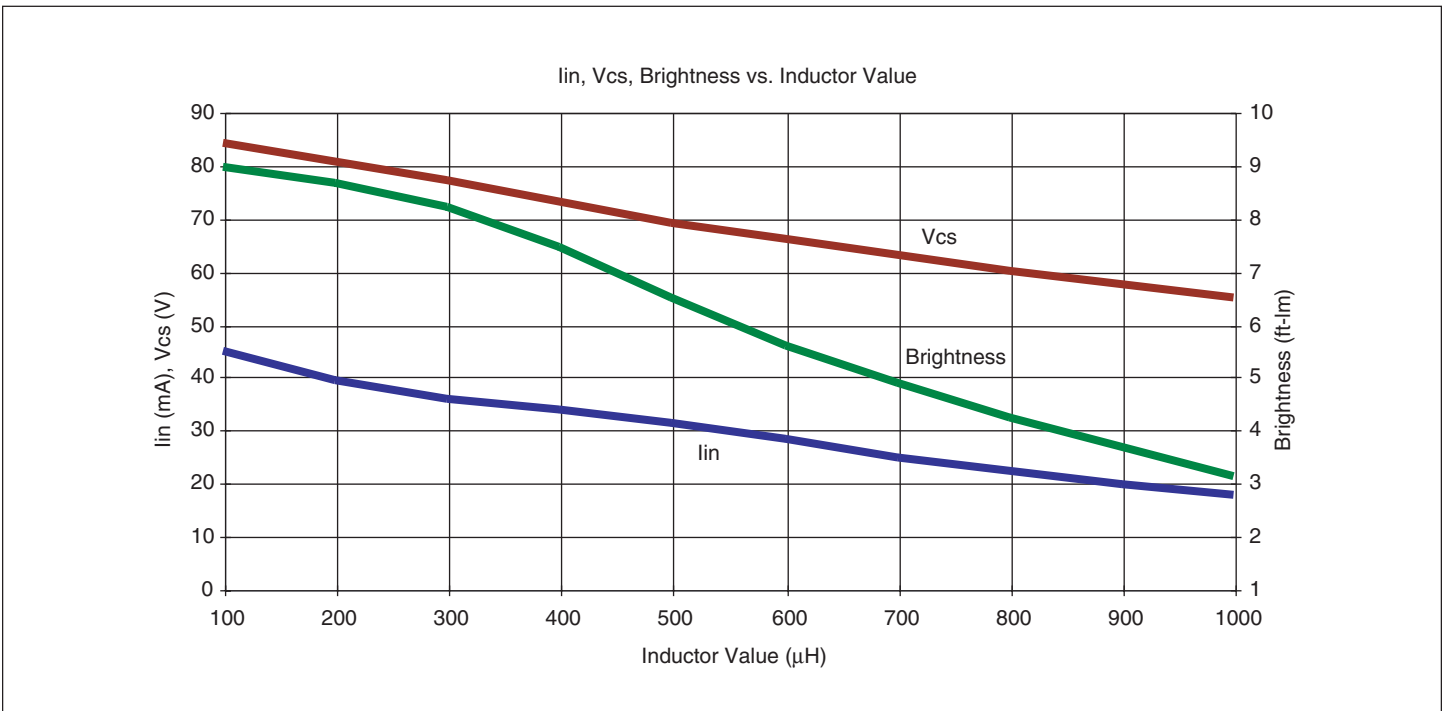
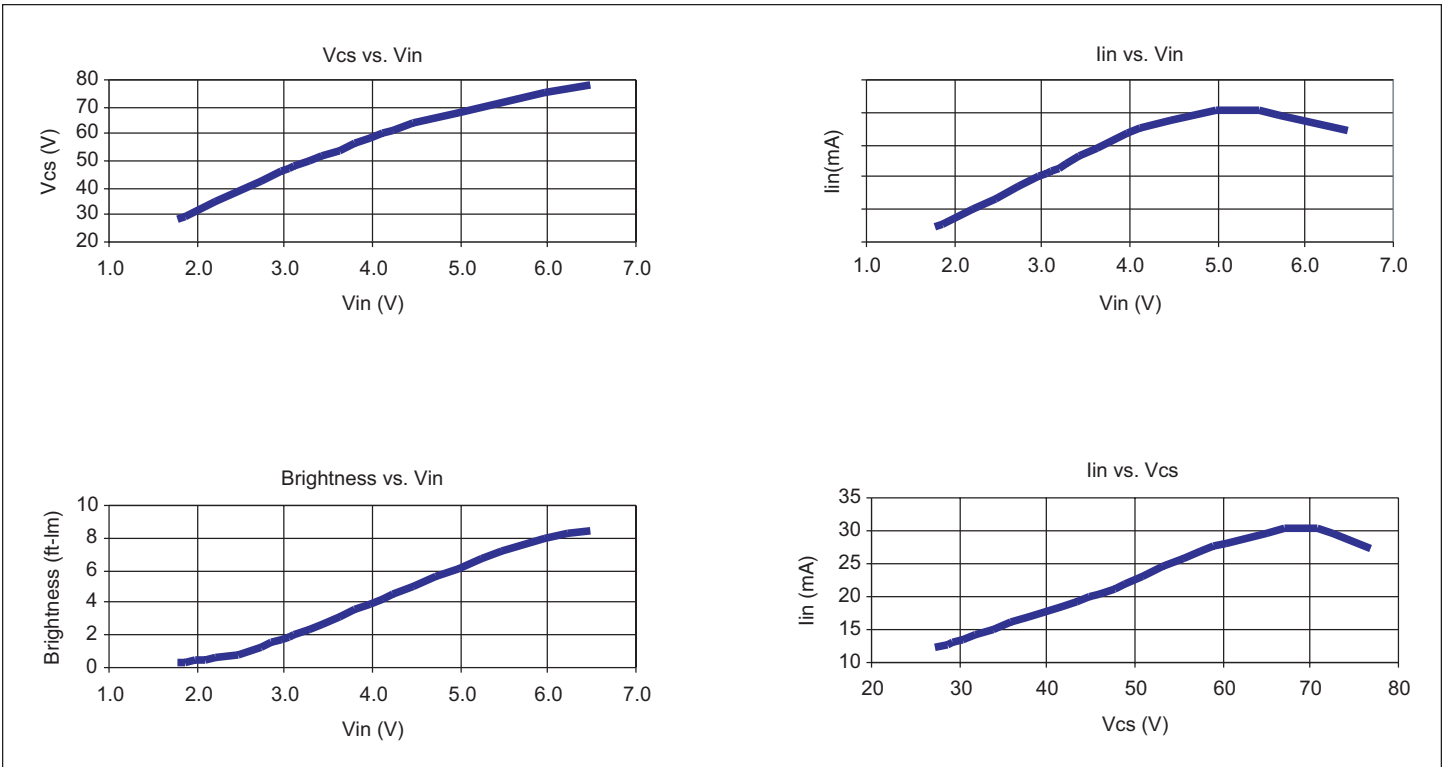
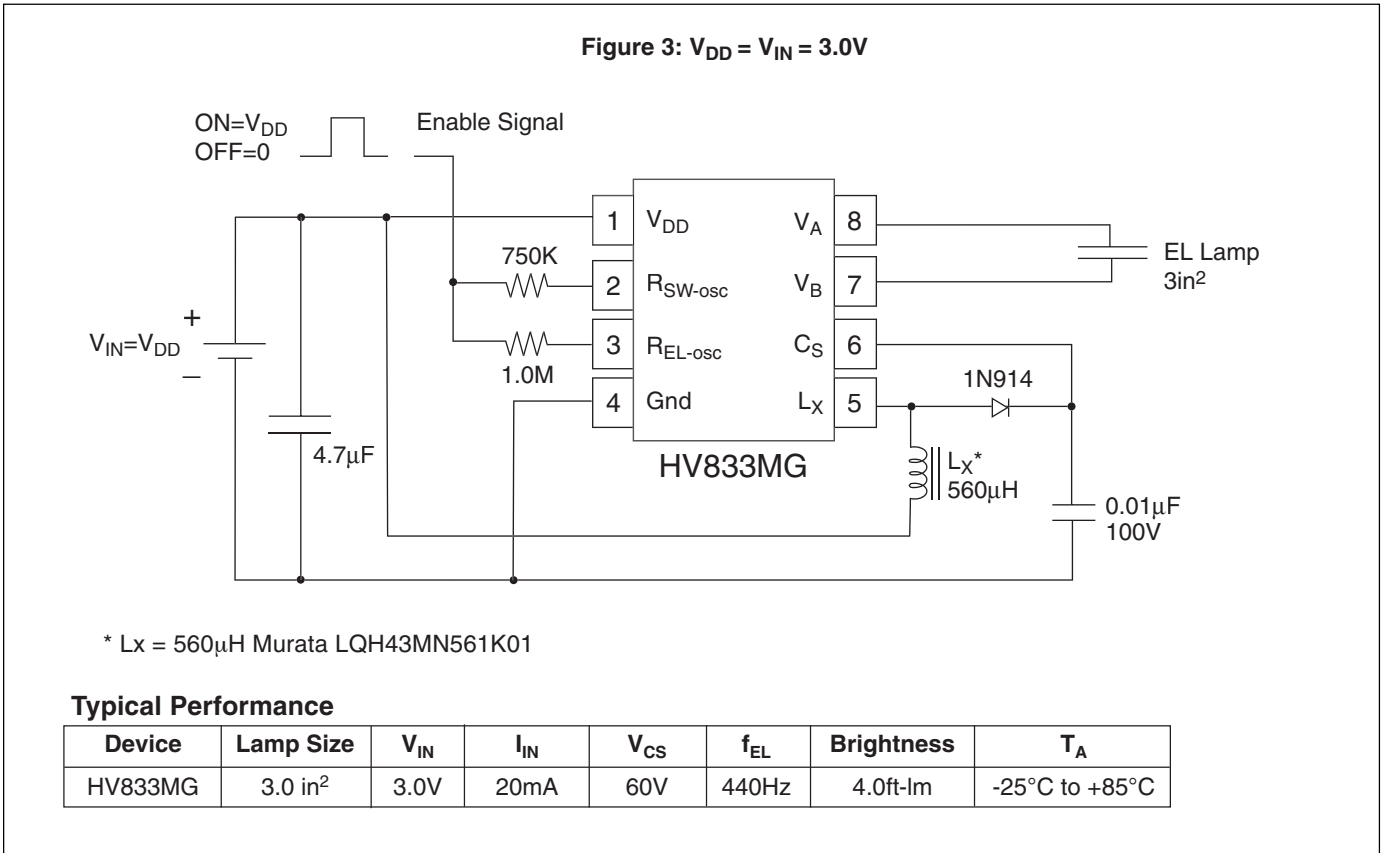
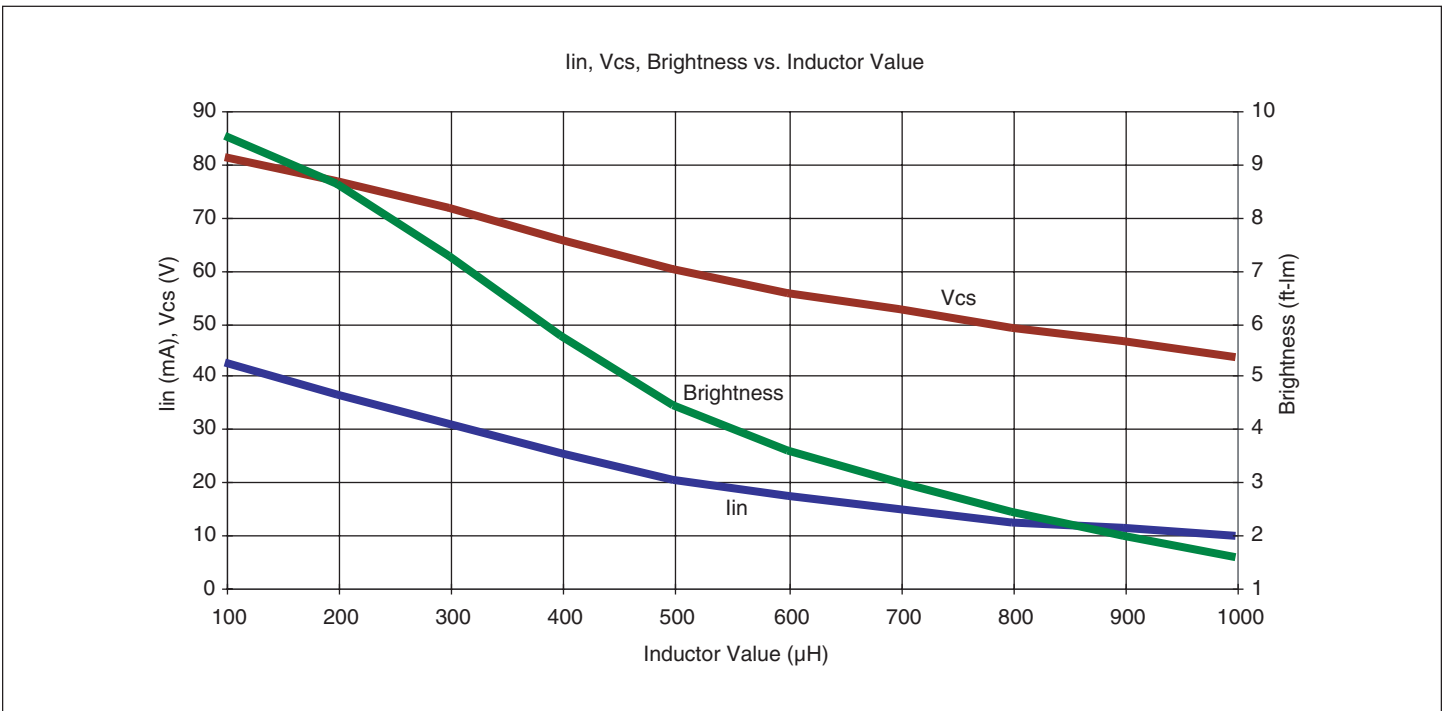
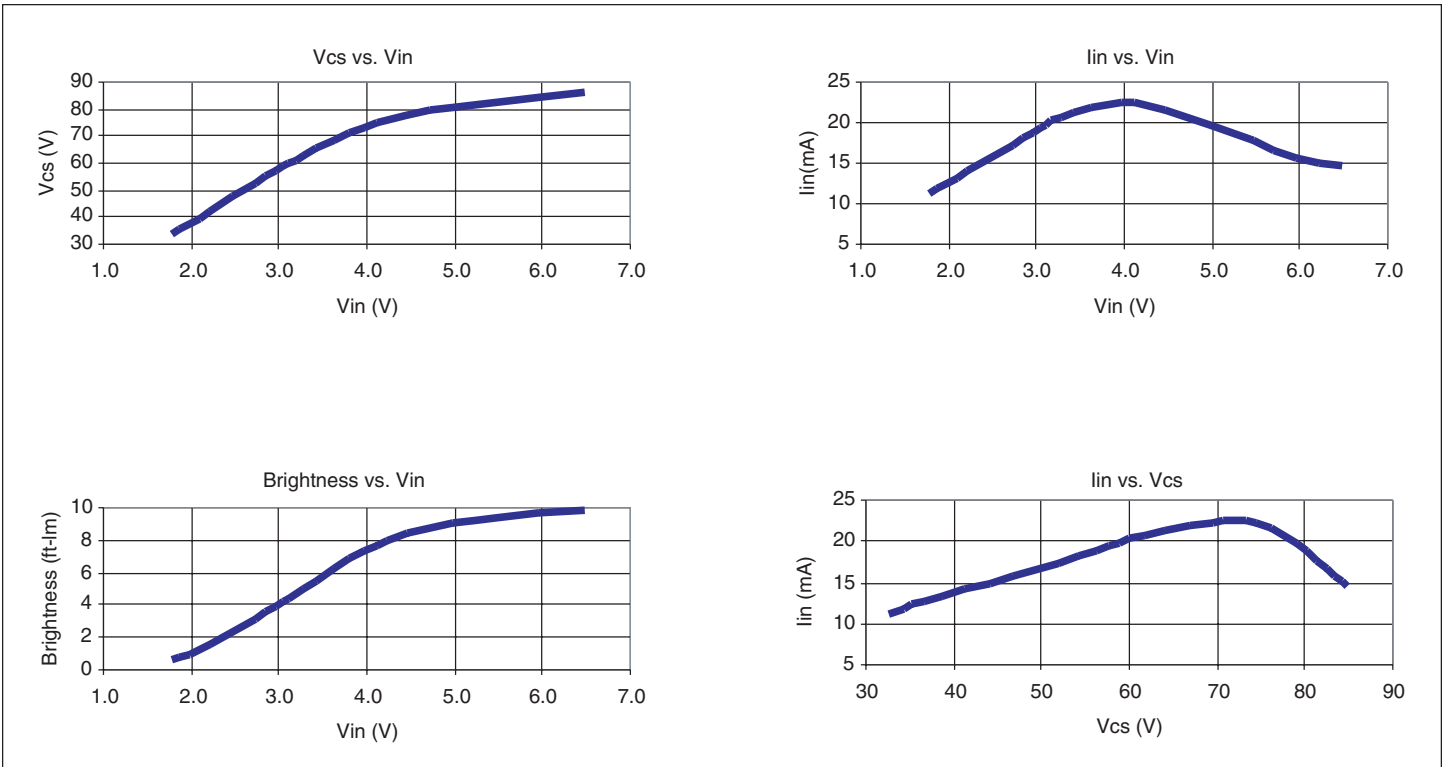

Figure 3: Typical Application



Typical Performance Curves for Figure 3 (EL Lamp= 3.0 in², V_{IN}=V_{DD}).



External Component Description

External Component	Selection Guide Line
Diode	Fast reverse recovery diode, 100V 1N4148 or equivalent.
Cs Capacitor	0.003 μ F to 0.1 μ F, 100V capacitor to GND is used to store the energy transferred from the inductor.
R _{EL-osc}	The EL lamp frequency is controlled via an external R _{EL} resistor connected between R _{EL-osc} and V _{DD} of the device. The lamp frequency increases as R _{EL} decreases. As the EL lamp frequency increases, the amount of current drawn from the battery will increase and the output voltage V _{CS} will decrease. The color of the EL lamp is dependent upon its frequency.
R _{SW-osc}	The switching frequency of the converter is controlled via an external resistor, R _{SW} between R _{SW-osc} and V _{DD} of the device. The switching frequency increases as R _{SW} decreases. With a given inductor, as the switching frequency increases, the amount of current drawn from the battery will decrease and the output voltage, V _{CS} , will also decrease.
Lx Inductor	<p>The inductor L_x is used to boost the low input voltage by inductive flyback. When the internal switch is on, the inductor is being charged. When the internal switch is off, the charge stored in the inductor will be transferred to the high voltage capacitor C_s. The energy stored in the capacitor is connected to the internal H-bridge and therefore to the EL lamp. In general, smaller value inductors, which can handle more current, are more suitable to drive larger size lamps. As the inductor value decreases, the switching frequency of the inductor (controlled by R_{SW}) should be increased to avoid saturation.</p> <p>220μH Murata (LQH43MN221) inductors with 5.4Ω series DC resistance is typically recommended. For inductors with the same inductance value but with lower series DC resistance, lower R_{SW} value is needed to prevent high current draw and inductor saturation.</p>
Lamp	As the EL lamp size increases, more current will be drawn from the battery to maintain high voltage across the EL lamp. The input power, (V _{IN} x I _{IN}), will also increase. If the input power is greater than the power dissipation of the package (300mW), an external resistor in series with one side of the lamp is recommended to help reduce the package power dissipation.

Enable/Disable Configuration

The HV833 can be easily enabled and disabled via a logic control signal on the R_{SW} and R_{EL} resistors as shown in the Typical Application Circuit on the front page. The control signal can be from a microprocessor. R_{SW} and R_{EL} are typically very high values. Therefore, only 10's of microamperes will be drawn from the logic signal when it is at a logic high (enable) state. When the microprocessor signal is high the device is enabled and when the signal is low, it is disabled.

Split Supply Configuration for Battery Voltages of Higher than 6.5V

The Typical Application Circuit on the first page can also be used with high battery voltages such as 12V as long as the input voltage, V_{DD}, to the HV833 device is within its specifications of 1.8V to 6.5V.