

Introduction

The Supertex HV833DB1 demo board contains all necessary circuitry to demonstrate the features of the HV833 EL lamp driver.

Simply connect it to a power supply and a lamp as shown below. For additional assistance in designing EL driver circuits, please refer to application notes AN-H33 (effect of external components on performance of Supertex EL drivers) and AN-H45 (EL lamp driver circuits to reduce lamp audible noise).

Specifications

Input Voltage	1.8V to 6.5V
Supply Current	45mA
Lamp Size Range	5.5in ² and 10in ²
Lamp Frequency	250Hz
Converter frequency	70KHz

Board Layout and Connections

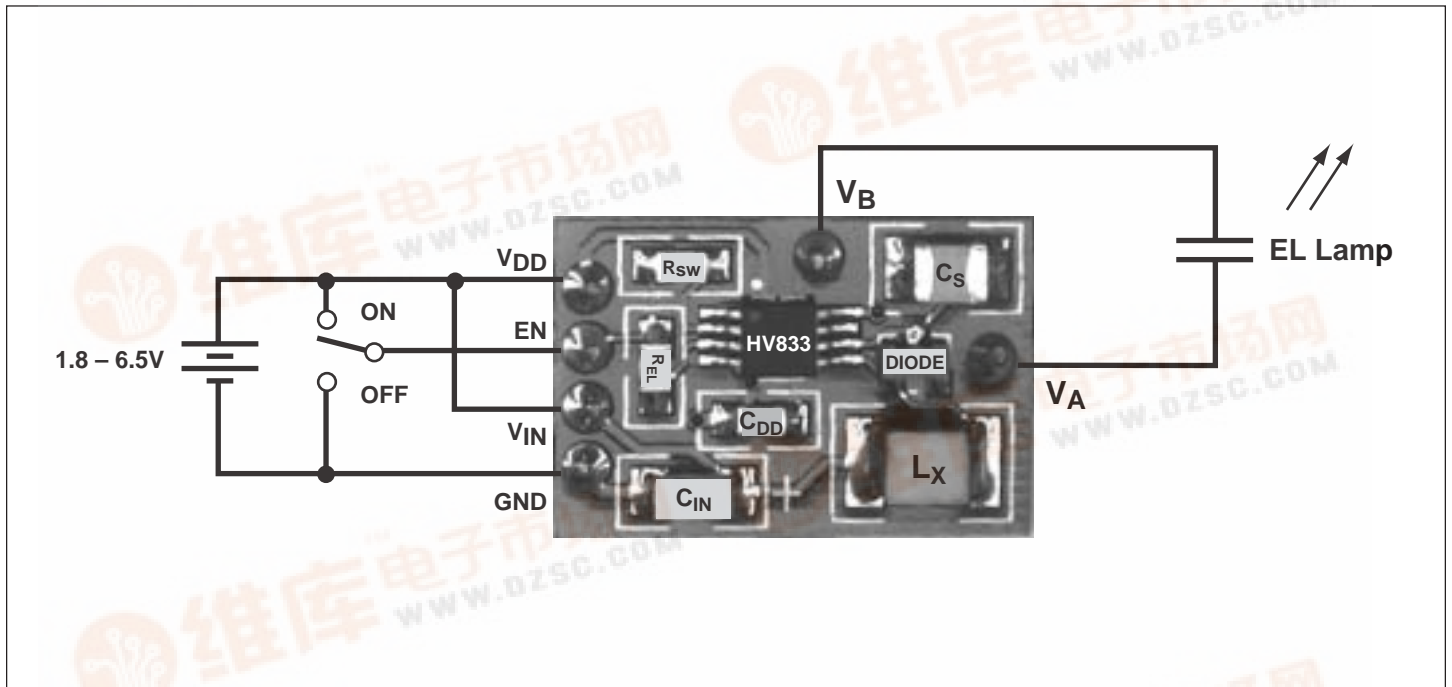

EN Enable Input

Enables/Disables the lamp driver. A logic high (V_{DD}) enables the driver and a logic low (GND) disables the driver. This input may be connected to a mechanical switch, or to a logic circuit output that has a source impedance of less than 20K Ω .

V_{DD} IC Supply

Supplies the HV833 EL driver IC. The supplied circuit is optimized for 1.8 to 6.5 volt operations.

V_{IN} Inductor Supply

Supplies the high voltage power converter.

GND Circuit Ground

Connect to V_{DD} and V_{IN} negative terminals. Supply bypass capacitor for both V_{DD} and V_{IN} are provided on the demo board. External supply bypass capacitors are not necessary.

V_A and V_B Lamp Connections

Connects to an EL lamp. Polarity is irrelevant.

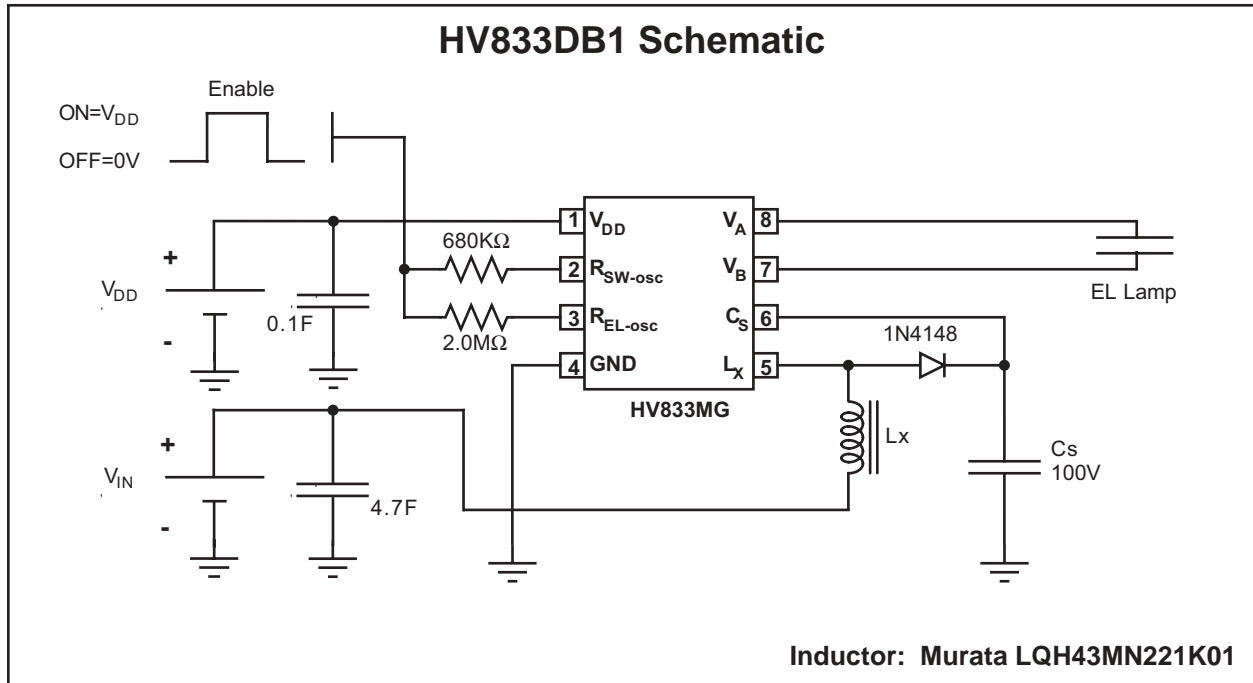

Typical Performance

The specific external components used in the above circuit are: Lx=220mH Murata (LQH43MN221K01), Cs= 10nF 100V NPO.

The following was observed when driving a 10in² Green lamp.

V _{IN} (V)	I _{IN} (mA)	V _{CS} (V)	f _{EL} (Hz)	Brightness	
				ft-lm	cd/ m ²
2.0	31.1	49.7	232	1.4	4.7
3.0	41.5	67.8	232	3.4	11.5
4.0	34.0	77.2	232	4.3	14.7
5.0	27.7	81.5	232	4.5	15.5
6.0	24.4	84.3	232	4.7	16.0
6.5	24.2	85.3	232	4.8	16.3

The following was observed when driving a 5.5in² Green lamp.

V _{IN} (V)	I _{IN} (mA)	V _{CS} (V)	f _{EL} (Hz)	Brightness	
				ft-lm	cd/ m ²
1.8	26.1	56.3	232	2.3	7.9
2.0	29.1	61.9	232	3.0	10.3
3.0	25.2	78.2	232	4.9	16.8
4.0	18.5	82.7	232	5.2	17.8
5.0	14.7	84.6	232	5.2	17.5
6.0	13.5	85.4	232	5.3	18.1
6.5	12.0	86.9	232	5.4	18.5