

查询5962-8515519SA供应商 TIBPAL16L8-7C, TIBPAL16R4-7C, TIBPAL16R6-7C, TIBPAL16R8-7C
 TIBPAL16L8-10M, TIBPAL16R4-10M, TIBPAL16R6-10M, TIBPAL16R8-10M
 HIGH-PERFORMANCE **IMPACT-X™** PAL® CIRCUITS

SRPS006D – D3115, MAY 1988 – REVISED MARCH 1992

- **High-Performance Operation:**
 - f_{max} (no feedback)
 - TIBPAL16R'-7C Series . . . 100 MHz Min
 - TIBPAL16R'-10M Series . . . 62.5 MHz Min
 - f_{max} (internal feedback)
 - TIBPAL16R'-7C Series . . . 100 MHz Min
 - TIBPAL16R'-10M Series . . . 62.5 MHz Min
 - f_{max} (external feedback)
 - TIBPAL16R'-7C Series . . . 74 MHz Min
 - TIBPAL16R'-10M Series . . . 52.5 MHz Min
 - Propagation Delay
 - TIBPAL16L'-7C Series . . . 7 ns Max
 - TIBPAL16L'-10M Series . . . 10 ns Max

- **Functionally Equivalent, but Faster than, Existing 20-Pin PLDs**
- **Preload Capability on Output Registers Simplifies Testing**
- **Power-Up Clear on Registered Devices (All Register Outputs are Set Low, but Voltage Levels at the Output Pins Go High)**
- **Package Options Include Both Plastic and Ceramic Chip Carriers in Addition to Plastic and Ceramic DIPs**
- **Security Fuse Prevents Duplication**
- **Dependable Texas Instruments Quality and Reliability**

DEVICE	I INPUTS	3-STATE O OUTPUTS	REGISTERED Q OUTPUTS	I/O PORTS
PAL16L8	10	2	0	6
PAL16R4	8	0	4 (3-state buffers)	4
PAL16R6	8	0	6 (3-state buffers)	2
PAL16R8	8	0	8 (3-state buffers)	0

description

These programmable array logic devices feature high speed and functional equivalency when compared with currently available devices. These IMPACT-X™ circuits combine the latest Advanced Low-Power Schottky technology with proven titanium-tungsten fuses to provide reliable, high-performance substitutes for conventional TTL logic. Their easy programmability allows for quick design of custom functions and typically results in a more compact circuit board. In addition, chip carriers are available for further reduction in board space.

All of the register outputs are set to a low level during power-up. Extra circuitry has been provided to allow loading of each register asynchronously to either a high or low state. This feature simplifies testing because the registers can be set to an initial state prior to executing the test sequence.

The TIBPAL16' C series is characterized from 0°C to 75°C. The TIBPAL16' M series is characterized for operation over the full military temperature range of -55°C to 125°C.

These devices are covered by U.S. Patent 4,410,987.
 IMPACT-X is a trademark of Texas Instruments Incorporated.
 PAL is a registered trademark of Advanced Micro Devices Inc.

TIBPAL16L8'
 C SUFFIX . . . J OR N PACKAGE
 M SUFFIX . . . J PACKAGE

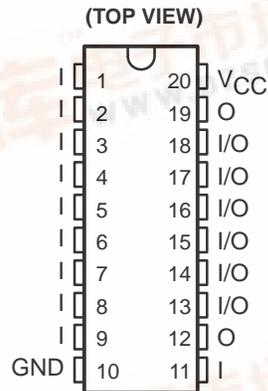

TIBPAL16L8'
 C SUFFIX . . . FN PACKAGE
 M SUFFIX . . . FK PACKAGE

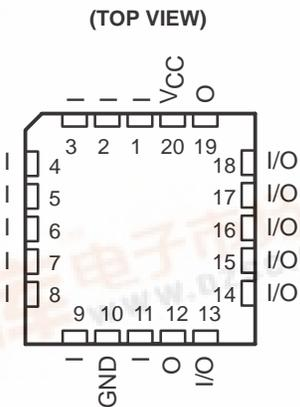

Pin assignments in operating mode

TIBPAL16R4-7C, TIBPAL16R6-7C, TIBPAL16R8-7C
TIBPAL16R4-10M, TIBPAL16R6-10M, TIBPAL16R8-10M
HIGH-PERFORMANCE *IMPACT-X*™ PAL® CIRCUITS

SRPS006D – D3115, MAY 1988 – REVISED MARCH 1992

TIBPAL16R4'
C SUFFIX . . . J OR N PACKAGE
M SUFFIX . . . J PACKAGE

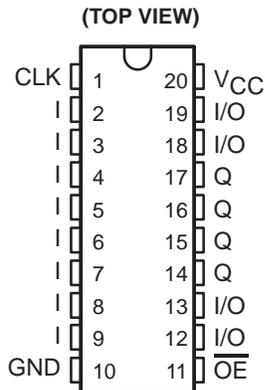

TIBPAL16R4'
C SUFFIX . . . FN PACKAGE
M SUFFIX . . . FK PACKAGE

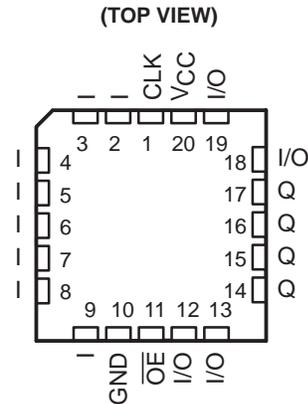

TIBPAL16R6'
C SUFFIX . . . J OR N PACKAGE
M SUFFIX . . . J PACKAGE

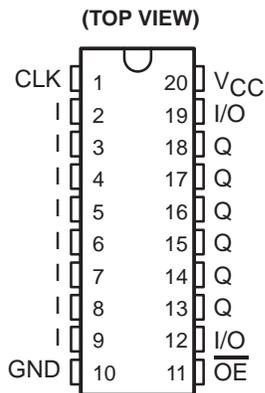

TIBPAL16R6'
C SUFFIX . . . FN PACKAGE
M SUFFIX . . . FK PACKAGE

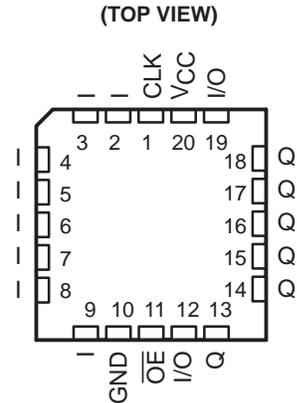

TIBPAL16R8'
C SUFFIX . . . J OR N PACKAGE
M SUFFIX . . . J PACKAGE

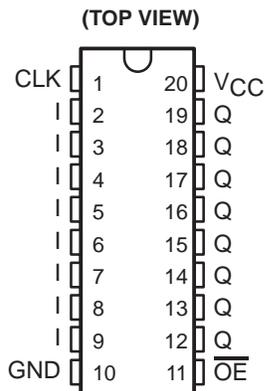

TIBPAL16R8'
C SUFFIX . . . FN PACKAGE
M SUFFIX . . . FK PACKAGE

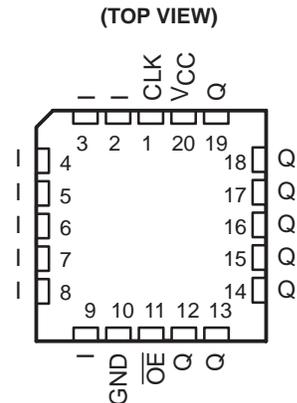

Pin assignments in operating mode

TIBPAL16L8-7C, TIBPAL16R4-7C
TIBPAL16L8-10M, TIBPAL16R4-10M
HIGH-PERFORMANCE *IMPACT-X*™ PAL® CIRCUITS
SRPS006D – D3115, MAY 1988 – REVISED MARCH 1992

functional block diagrams (positive logic)

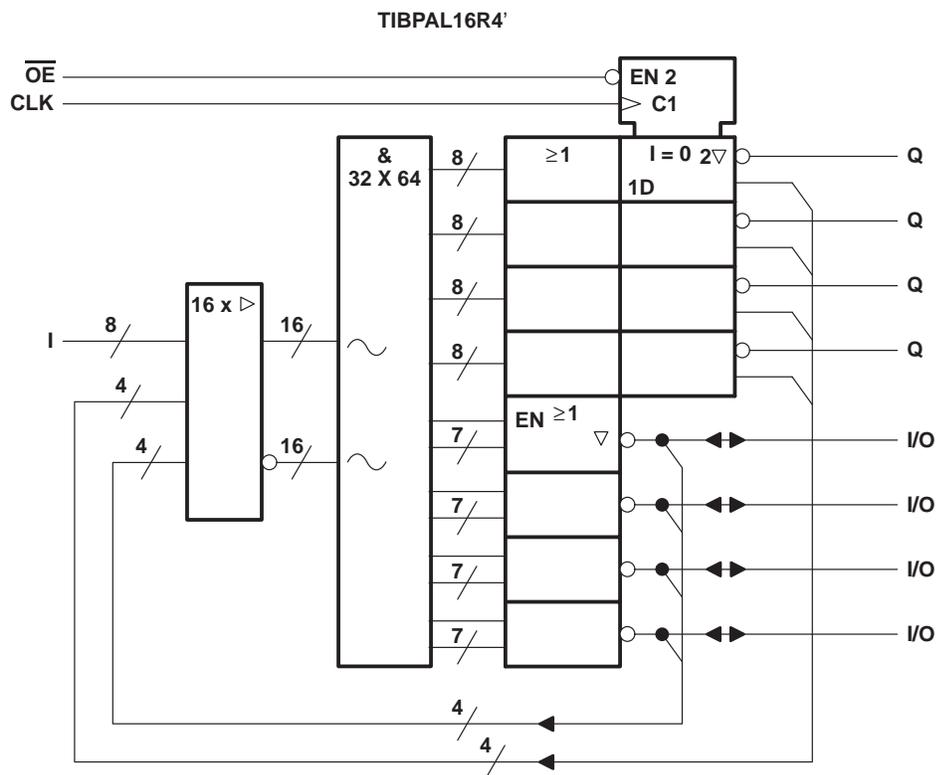
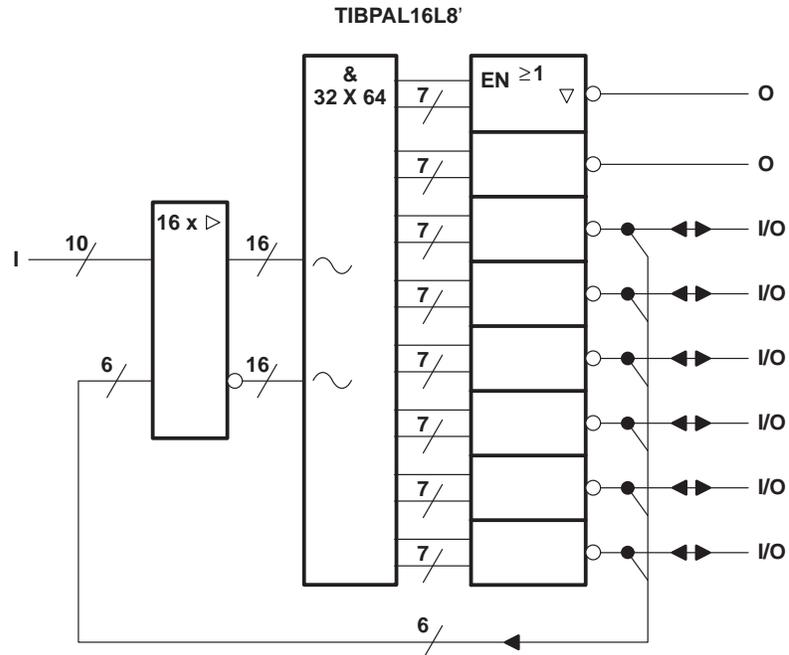

~ denotes fused inputs

TIBPAL16R6-7C, TIBPAL16R8-7C
 TIBPAL16R6-10M, TIBPAL16R8-10M
 HIGH-PERFORMANCE *IMPACT-X*™ *PAL*® CIRCUITS
 SRPS006D – D3115, MAY 1988 – REVISED MARCH 1992

functional block diagrams (positive logic)

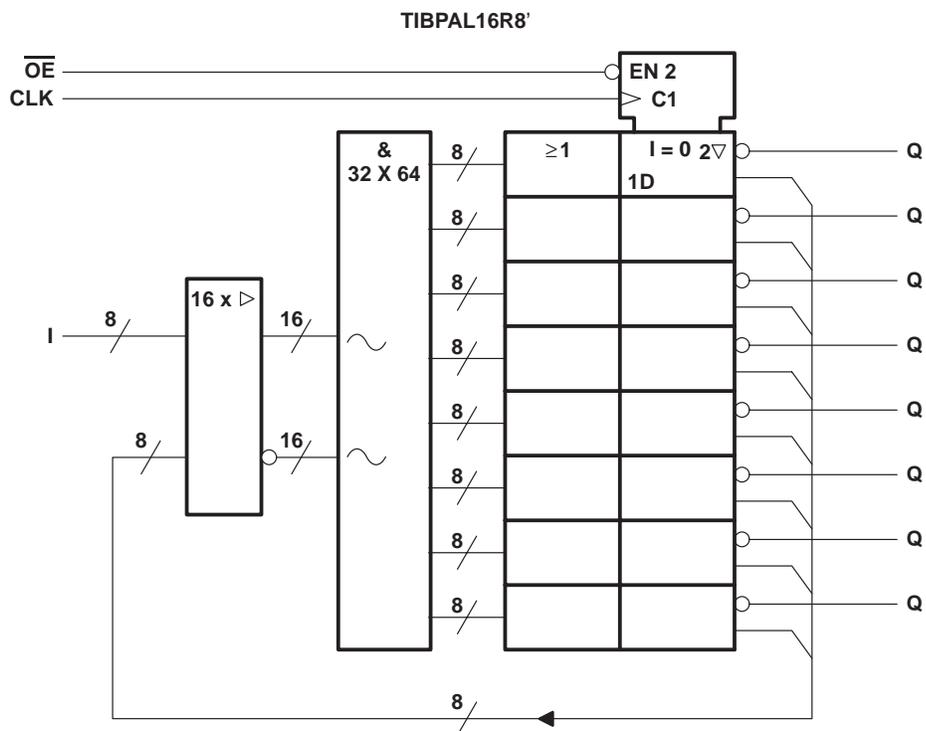
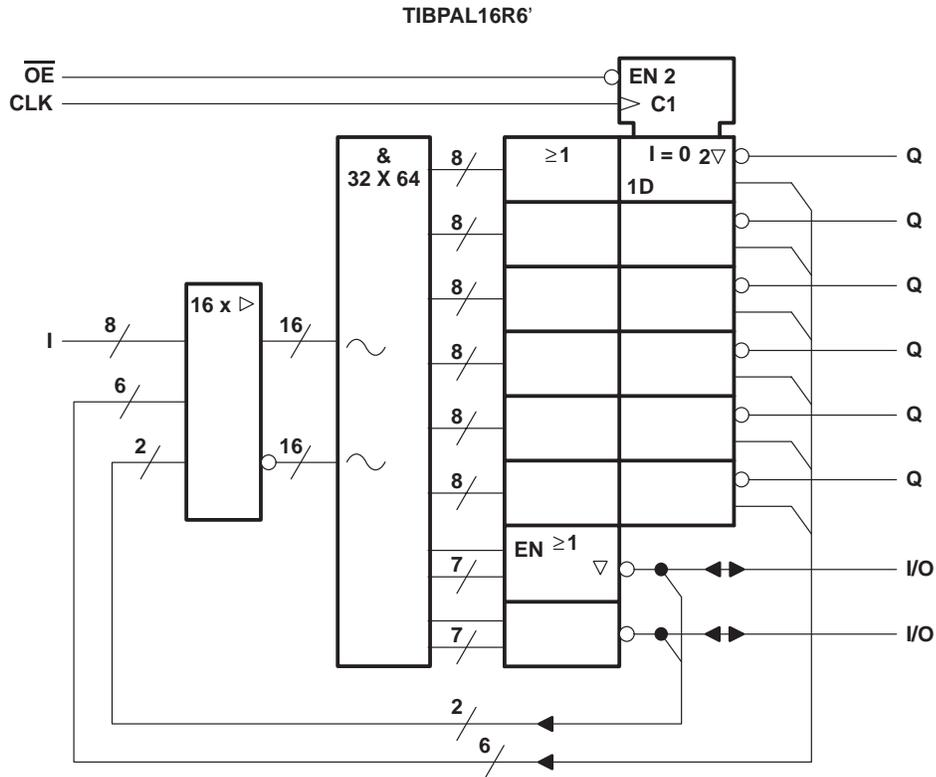

~ denotes fused inputs

logic diagram (positive logic)

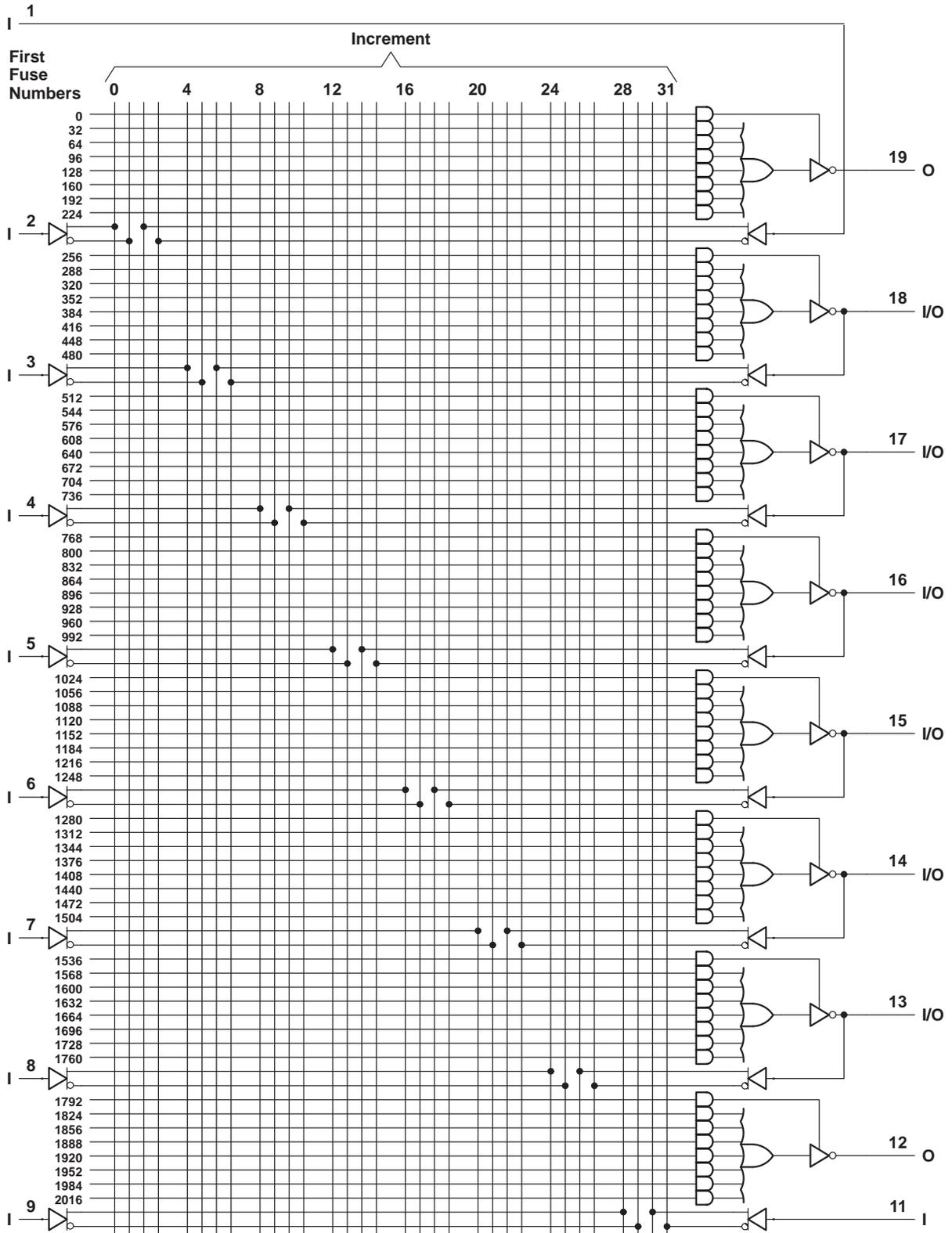

Fuse number = First fuse number + Increment

TIBPAL16R4-7C
TIBPAL16R4-10M
HIGH-PERFORMANCE *IMPACT-X*™ PAL® CIRCUITS
 SRPS006D – D3115, MAY 1988 – REVISED MARCH 1992

logic diagram (positive logic)

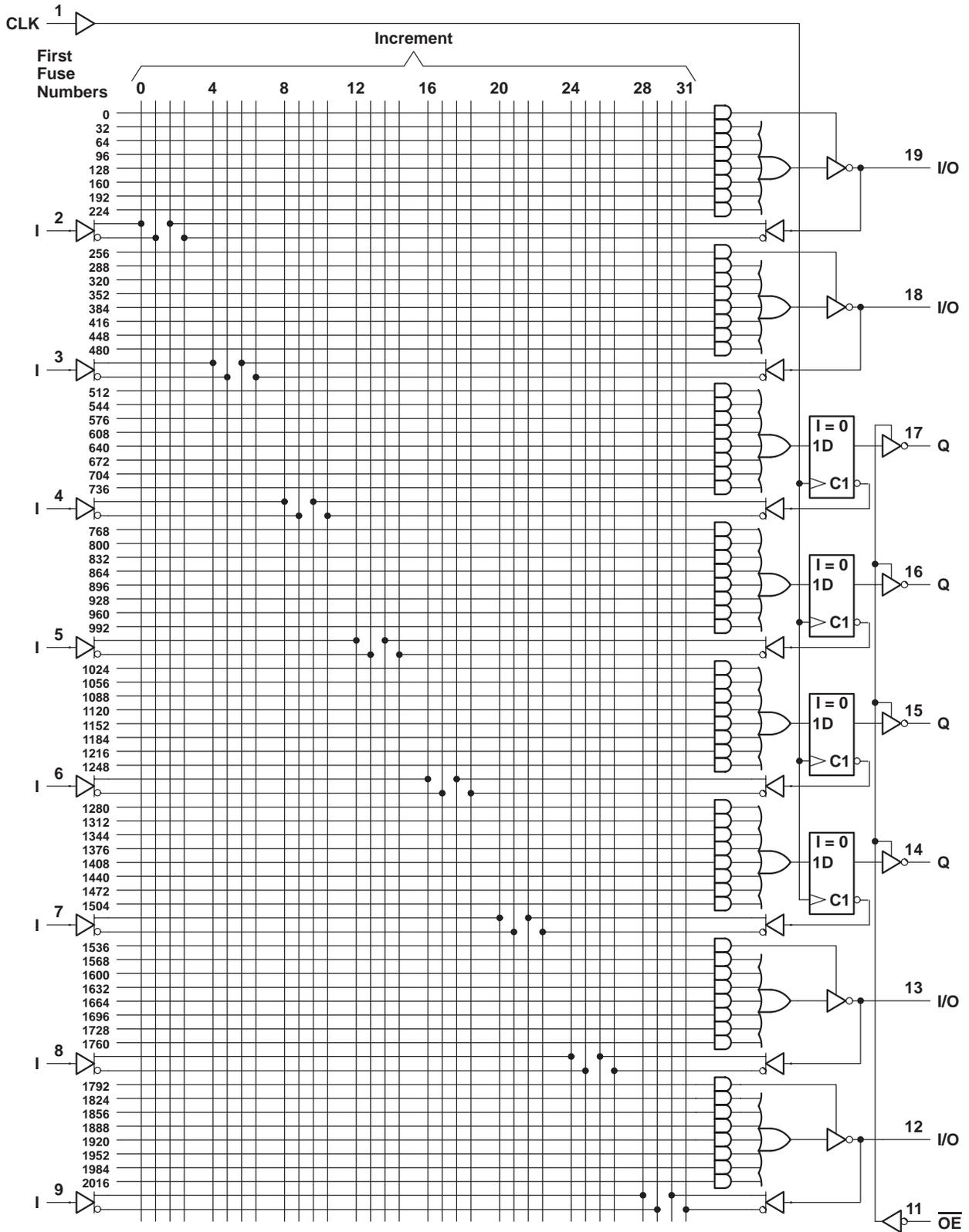

logic diagram (positive logic)

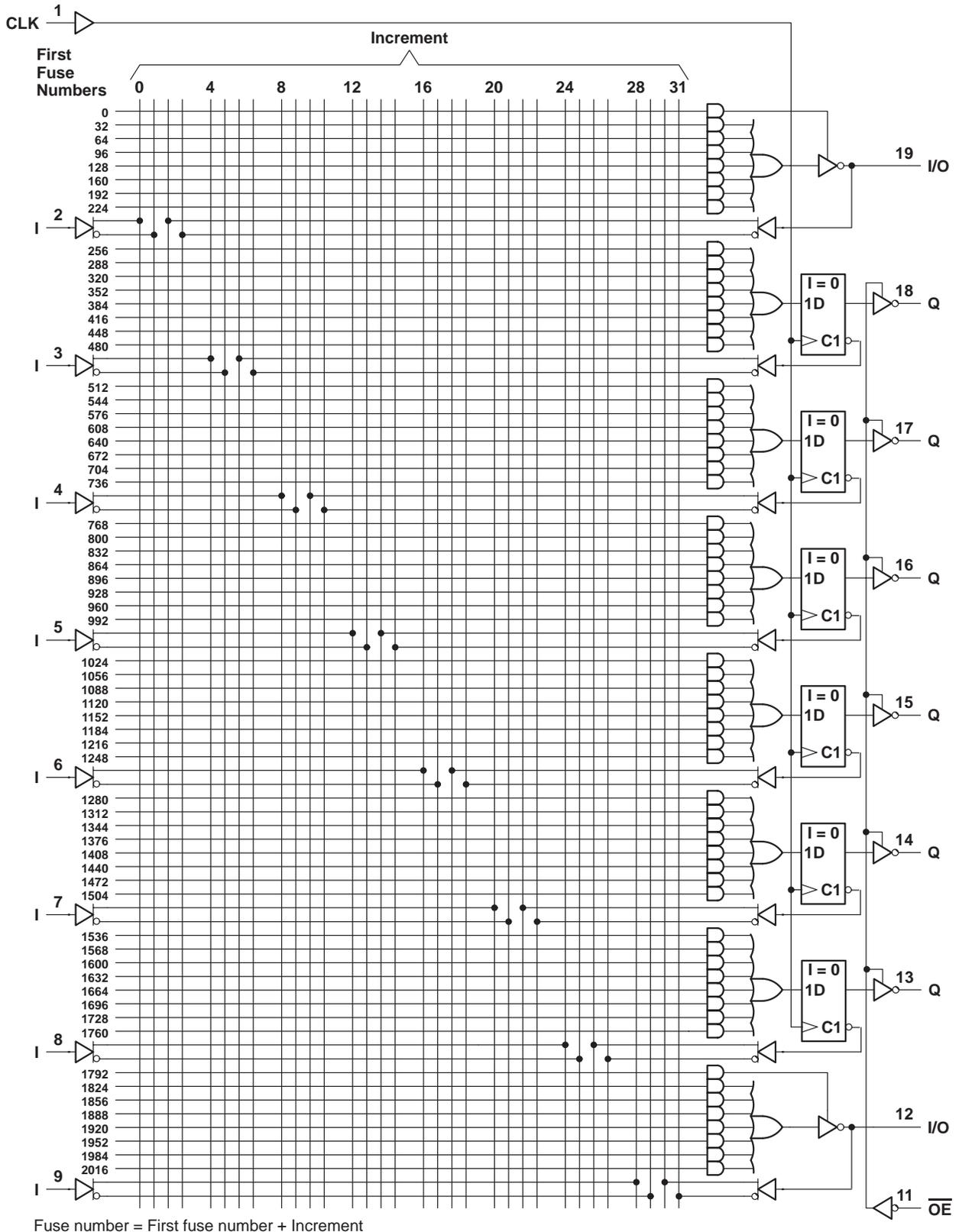

TIBPAL16R8-7C
TIBPAL16R8-10M
HIGH-PERFORMANCE *IMPACT-X*™ PAL® CIRCUITS
 SRPS006D – D3115, MAY 1988 – REVISED MARCH 1992

logic diagram (positive logic)

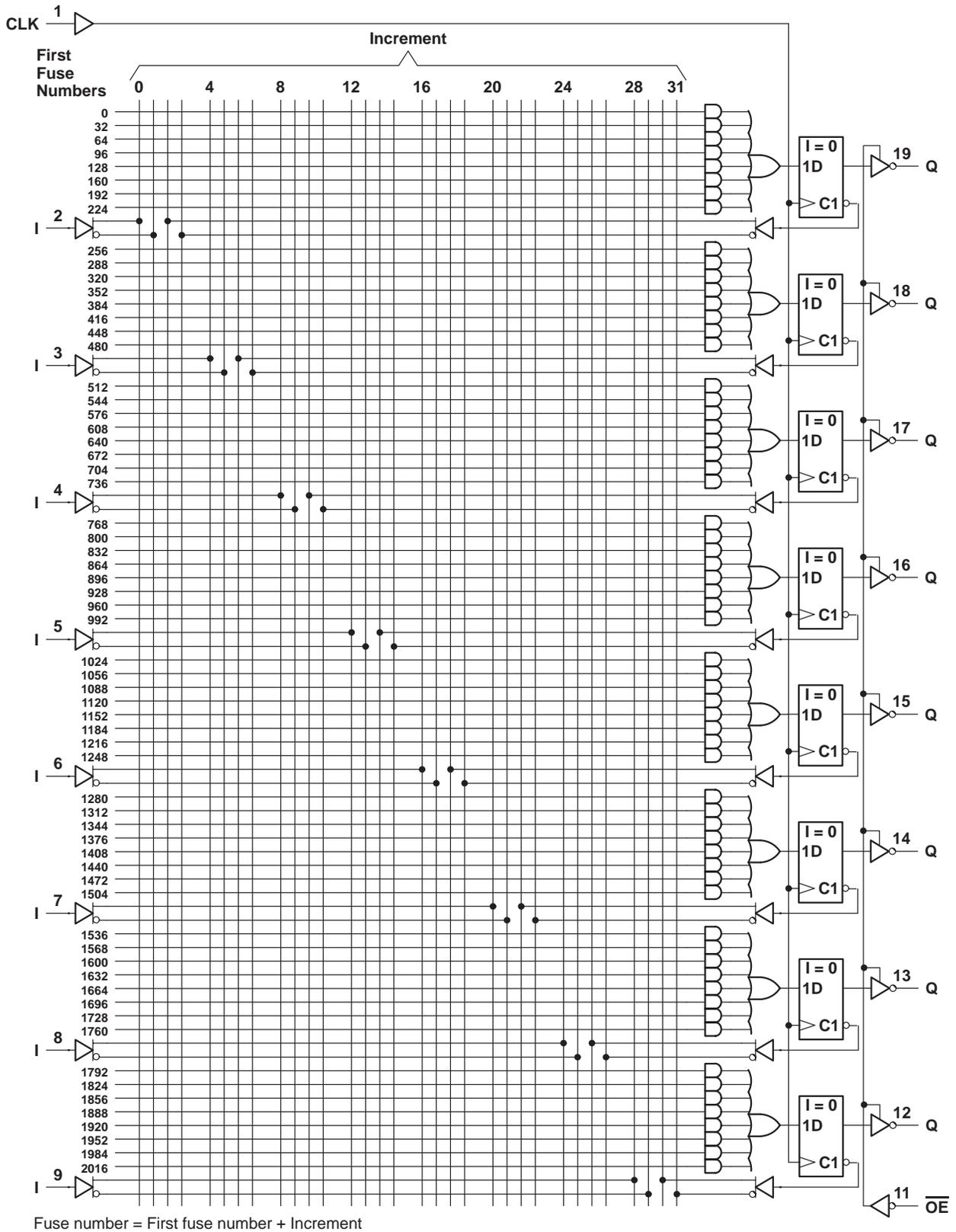

TIBPAL16L8-7C, TIBPAL16R4-7C, TIBPAL16R6-7C, TIBPAL16R8-7C HIGH-PERFORMANCE *IMPACT-X*[™] PAL[®] CIRCUITS

SRPS006D – D3115, MAY 1988 – REVISED MARCH 1992

absolute maximum ratings over operating free-air temperature range (unless otherwise noted)

Supply voltage, V_{CC} (see Note 1)	7 V
Input voltage (see Note 1)	5.5 V
Voltage applied to disabled output (see Note 1)	5.5 V
Operating free-air temperature range	0°C to 75°C
Storage temperature range	–65°C to 150°C

NOTE 1: These ratings apply except for programming pins during a programming cycle.

recommended operating conditions

		MIN	NOM	MAX	UNIT
V_{CC}	Supply voltage	4.75	5	5.25	V
V_{IH}	High-level input voltage (see Note 2)	2		5.5	V
V_{IL}	Low-level input voltage (see Note 2)			0.8	V
I_{OH}	High-level output current			–3.2	mA
I_{OL}	Low-level output current			24	mA
f_{clock}	Clock frequency	0		100	MHz
t_w	Pulse duration, clock (see Note 2)	High		5	ns
		Low		5	
t_{su}	Setup time, input or feedback before clock [†]	7			ns
t_h	Hold time, input or feedback after clock [†]	0			ns
T_A	Operating free-air temperature	0	25	75	°C

NOTE 2: These are absolute voltage levels with respect to the ground pin of the device and include all overshoots due to system and/or tester noise. Testing these parameters should not be attempted without suitable equipment.

electrical characteristics over recommended operating free-air temperature range

PARAMETER	TEST CONDITIONS		MIN	TYP [†]	MAX	UNIT
V_{IK}	$V_{CC} = 4.75$ V,	$I_I = -18$ mA		–0.8	–1.5	V
V_{OH}	$V_{CC} = 4.75$ V,	$I_{OH} = -3.2$ mA	2.4	3.2		V
V_{OL}	$V_{CC} = 4.75$ V,	$I_{OL} = 24$ mA		0.3	0.5	V
I_{OZH}^{\ddagger}	$V_{CC} = 5.25$ V,	$V_O = 2.7$ V			100	μA
I_{OZL}^{\ddagger}	$V_{CC} = 5.25$ V,	$V_O = 0.4$ V			–100	μA
I_I	$V_{CC} = 5.25$ V,	$V_I = 5.5$ V			100	μA
I_{IH}^{\ddagger}	$V_{CC} = 5.25$ V,	$V_I = 2.7$ V			25	μA
I_{IL}^{\ddagger}	$V_{CC} = 5.25$ V,	$V_I = 0.4$ V		–80	–250	μA
I_{OS}^{\S}	$V_{CC} = 5.25$ V,	$V_O = 0.5$ V	–30	–70	–130	mA
I_{CC}	$V_{CC} = 5.25$ V,	$V_I = 0$, Outputs open		160	180	mA
C_i	$f = 1$ MHz,	$V_I = 2$ V		5		pF
C_o	$f = 1$ MHz,	$V_O = 2$ V		6		pF
C_{clk}	$f = 1$ MHz,	$V_{CLK} = 2$ V		6		pF

[†] All typical values are at $V_{CC} = 5$ V, $T_A = 25^\circ\text{C}$.

[‡] I/O leakage is the worst case of I_{OZL} and I_{IL} or I_{OZH} and I_{IH} respectively.

[§] Not more than one output should be shorted at a time, and the duration of the short circuit should not exceed one second. V_O is set at 0.5 V to avoid test problems caused by test equipment ground degradation.

TIBPAL16L8-7C, TIBPAL16R4-7C, TIBPAL16R6-7C, TIBPAL16R8-7C HIGH-PERFORMANCE *IMPACT-X*™ *PAL*® CIRCUITS

SRPS006D – D3115, MAY 1988 – REVISED MARCH 1992

switching characteristics over recommended ranges of supply voltage and operating free-air temperature (unless otherwise noted)

PARAMETER	FROM (INPUT)	TO (OUTPUT)	TEST CONDITION	MIN	TYP†	MAX	UNIT	
f_{max}^{\ddagger}	without feedback		R1 = 200 Ω , R2 = 390 Ω , See Figure 6	100			MHz	
	with internal feedback (counter configuration)			100				
	with external feedback			74				
t_{pd}	I, I/O	O, I/O		1 or 2 outputs switching	3	5.5	7	ns
				8 outputs switching	3	6	7.5	
t_{pd}	CLK \uparrow	Q			2	4	6.5	ns
t_{pd}^{\S}	CLK \uparrow	Feedback input					3	ns
t_{en}	OE \downarrow	Q				4	7.5	ns
t_{dis}	OE \uparrow	Q				4	7.5	ns
t_{en}	I, I/O	O, I/O				6	9	ns
t_{dis}	I, I/O	O, I/O			6	9	ns	
$t_{sk(o)}^{\parallel}$	Skew between registered outputs				0.5		ns	

† All typical values are at $V_{CC} = 5\text{ V}$, $T_A = 25^\circ\text{C}$.

‡ See section for f_{max} specifications.

§ This parameter applies to TIBPAL16R4' and TIBPAL16R6' only (see Figure 4 for illustration) and is calculated from the measured f_{max} with internal feedback in the counter configuration.

¶ This parameter is the measurement of the difference between the fastest and slowest t_{pd} (CLK-to-Q) observed when multiple registered outputs are switching in the same direction.

TIBPAL16L8-10M, TIBPAL16R4-10M, TIBPAL16R6-10M, TIBPAL16R8-10M HIGH-PERFORMANCE *IMPACT-X*[™] PAL[®] CIRCUITS

SRPS006D – D3115, MAY 1988 – REVISED MARCH 1992

absolute maximum ratings over operating free-air temperature range (unless otherwise noted)

Supply voltage, V_{CC} (see Note 1)	7 V
Input voltage (see Note 1)	5.5 V
Voltage applied to disabled output (see Note 1)	5.5 V
Operating free-air temperature range	–55°C to 125°C
Storage temperature range	–65°C to 150°C

NOTE 1: These ratings apply except for programming pins during a programming cycle.

recommended operating conditions

		MIN	NOM	MAX	UNIT
V_{CC}	Supply voltage	4.5	5	5.5	V
V_{IH}	High-level input voltage	2		5.5	V
V_{IL}	Low-level input voltage			0.8	V
I_{OH}	High-level output current			–2	mA
I_{OL}	Low-level output current			12	mA
f_{clock}^{\dagger}	Clock frequency	0		62.5	MHz
t_w	Pulse duration, clock (see Note 2)	High		8	ns
		Low		8	
t_{su}^{\dagger}	Setup time, input or feedback before clock \uparrow	10			ns
t_h^{\dagger}	Hold time, input or feedback after clock \uparrow	0			ns
T_A	Operating free-air temperature	–55	25	125	°C

NOTE 2: These are absolute voltage levels with respect to the ground pin of the device and include all overshoots due to system and/or tester noise. Testing these parameters should not be attempted without suitable equipment.

electrical characteristics over recommended operating free-air temperature range

PARAMETER	TEST CONDITIONS		MIN	TYP [†]	MAX	UNIT
V_{IK}	$V_{CC} = 4.5$ V,	$I_I = -18$ mA		–0.8	–1.5	V
V_{OH}	$V_{CC} = 4.5$ V,	$I_{OH} = -2$ mA	2.4	3.2		V
V_{OL}	$V_{CC} = 4.5$ V,	$I_{OL} = 12$ mA		0.3	0.5	V
I_{OZH}^{\ddagger}	$V_{CC} = 5.5$ V,	$V_O = 2.7$ V			100	μA
I_{OZL}^{\ddagger}	0, Q outputs	$V_{CC} = 5.5$ V,	$V_O = 0.4$ V		–0.1	mA
	I/O ports				–0.25	
I_I	$V_{CC} = 5.5$ V,	$V_I = 5.5$ V			1	mA
I_{IH}	I/O ports	$V_{CC} = 5.5$ V,	$V_I = 2.7$ V		100	μA
	All others				25	
I_{IL}^{\ddagger}	$V_{CC} = 5.5$ V,	$V_I = 0.4$ V		–0.08	–0.25	mA
I_{OS}^{\S}	$V_{CC} = 5.5$ V,	$V_O = 0.5$ V	–30	–70	–130	mA
I_{CC}	$V_{CC} = 5.5$ V,	$V_I = GND$, Outputs open		140	200	mA
C_i	$f = 1$ MHz,	$V_I = 2$ V		5		pF
C_o	$f = 1$ MHz,	$V_O = 2$ V		6		pF
$C_{clk/oe}$	$f = 1$ MHz,	$V_{CLK/OE} = 2$ V		6		pF

[†] All typical values are at $V_{CC} = 5$ V, $T_A = 25^\circ\text{C}$.

[‡] I/O leakage is the worst case of I_{OZL} and I_{IL} or I_{OZH} and I_{IH} respectively.

[§] Not more than one output should be shorted at a time, and the duration of the short circuit should not exceed one second. V_O is set at 0.5 V to avoid test problems caused by test equipment ground degradation.

TIBPAL16L8-10M, TIBPAL16R4-10M, TIBPAL16R6-10M, TIBPAL16R8-10M HIGH-PERFORMANCE *IMPACT-X*[™] PAL[®] CIRCUITS

SRPS006C – D3115, MAY 1988 – REVISED OCTOBER 1990

switching characteristics over recommended ranges of supply voltage and operating free-air temperature (unless otherwise noted)

PARAMETER	FROM (INPUT)	TO (OUTPUT)	TEST CONDITION	MIN	TYP†	MAX	UNIT	
f_{\max}^{\ddagger}	without feedback		R1 = 390 Ω , R2 = 750 Ω , See Figure 6	62.5			MHz	
	with internal feedback (counter configuration)			62.5				
	with external feedback			52.5				
t_{pd}	I, I/O	O, I/O		2	6	10	ns	
t_{pd}	CLK \uparrow	Q		1	4	9	ns	
t_{pd}^{\S}	CLK \uparrow	Feedback input					5	ns
t_{en}	OE \downarrow	Q		1	4	10	ns	
t_{dis}	OE \uparrow	Q		1	4	10	ns	
t_{en}	I, I/O	O, I/O	2	6	12	ns		
t_{dis}	I, I/O	O, I/O	1	6	10	ns		

† All typical values are at $V_{CC} = 5\text{ V}$, $T_A = 25^\circ\text{C}$.

‡ See section for f_{\max} specifications. f_{\max} with external feedback is not production tested but is calculated from the equation found in the f_{\max} section.

§ This parameter applies to TIBPAL16R4' and TIBPAL16R6' only (see Figure 4 for illustration) and is calculated from the measured f_{\max} with internal feedback in the counter configuration.

**TIBPAL16L8-7C, TIBPAL16R4-7C, TIBPAL16R6-7C, TIBPAL16R8-7C
TIBPAL16L8-10M, TIBPAL16R4-10M, TIBPAL16R6-10M, TIBPAL16R8-10M
HIGH-PERFORMANCE *IMPACT-X*™ PAL® CIRCUITS**

SRPS006D – D3115, MAY 1988 – REVISED MARCH 1992

programming information

Texas Instruments programmable logic devices can be programmed using widely available software and inexpensive device programmers.

Complete programming specifications, algorithms, and the latest information on hardware, software, and firmware are available upon request. Information on programmers capable of programming Texas Instruments programmable logic is also available, upon request, from the nearest TI field sales office, local authorized TI distributor, or by calling Texas Instruments at (214) 997-5666.

preload procedure for registered outputs (see Figure 1 and Note 3)

The output registers can be preloaded to any desired state during device testing. This permits any state to be tested without having to step through the entire state-machine sequence. Each register is preloaded individually by following the steps given below.

- Step 1. With V_{CC} at 5 volts and Pin 1 at V_{IL} , raise Pin 11 to V_{IHH} .
- Step 2. Apply either V_{IL} or V_{IH} to the output corresponding to the register to be preloaded.
- Step 3. Pulse Pin 1, clocking in preload data.
- Step 4. Remove output voltage, then lower Pin 11 to V_{IL} . Preload can be verified by observing the voltage level at the output pin.

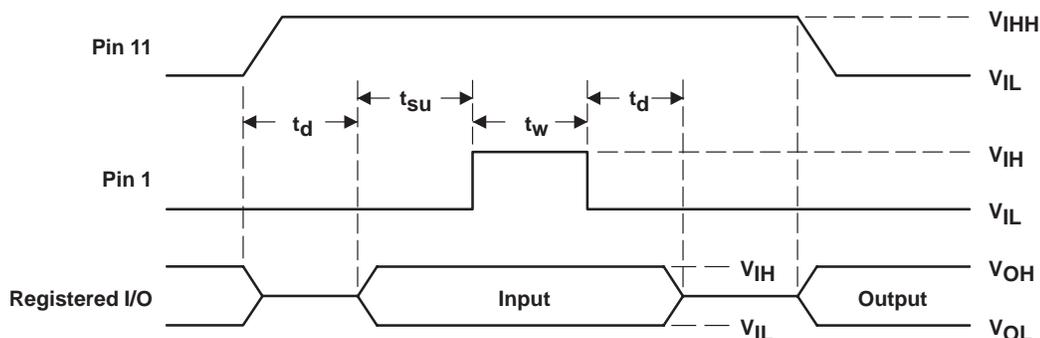

Figure 1. Preload Waveforms

NOTE 3: $t_d = t_{su} = t_h = 100 \text{ ns to } 1000 \text{ ns}$ $V_{IHH} = 10.25 \text{ V to } 10.75 \text{ v}$

TIBPAL16L8-7C, TIBPAL16R4-7C, TIBPAL16R6-7C, TIBPAL16R8-7C
TIBPAL16L8-10M, TIBPAL16R4-10M, TIBPAL16R6-10M, TIBPAL16R8-10M
HIGH-PERFORMANCE *IMPACT-X*[™] PAL[®] CIRCUITS
SRPS006D – D3115, MAY 1988 – REVISED MARCH 1992

power-up reset (see Figure 2)

Following power up, all registers are reset to zero. This feature provides extra flexibility to the system designer and is especially valuable in simplifying state-machine initialization. To ensure a valid power-up reset, it is important that the rise of V_{CC} be monotonic. Following power-up reset, a low-to-high clock transition must not occur until all applicable input and feedback setup times are met.

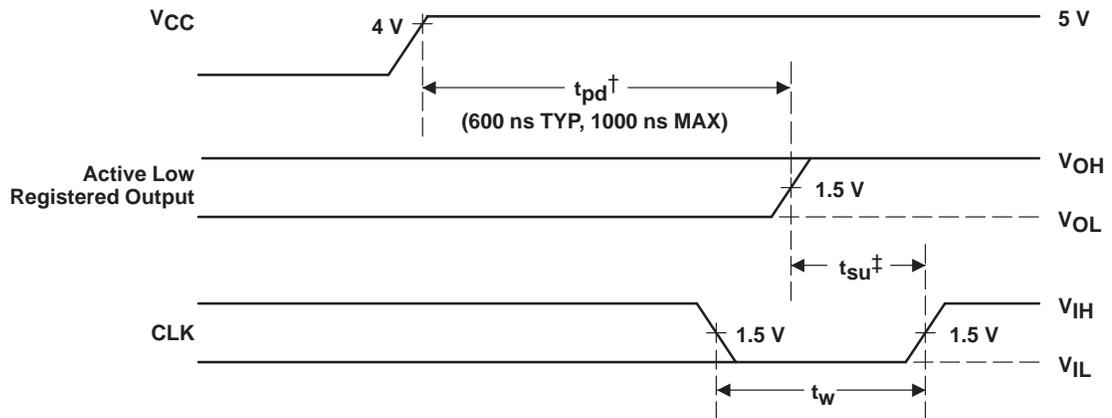

† This is the power-up reset time and applies to registered outputs only. The values shown are from characterization data.

‡ This is the setup time for input or feedback.

Figure 2. Power-Up Reset Waveforms

f_{\max} SPECIFICATIONS

f_{\max} without feedback, see Figure 3

In this mode, data is presented at the input to the flip-flop and clocked through to the Q output with no feedback. Under this condition, the clock period is limited by the sum of the data setup time and the data hold time ($t_{su} + t_h$). However, the minimum f_{\max} is determined by the minimum clock period ($t_w \text{ high} + t_w \text{ low}$).

$$\text{Thus, } f_{\max} \text{ without feedback} = \frac{1}{(t_{w\text{high}} + t_{w\text{low}})} \text{ or } \frac{1}{(t_{su} + t_h)}$$

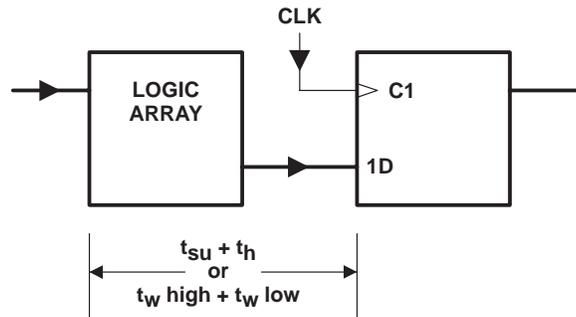

Figure 3. f_{\max} Without Feedback

f_{\max} with internal feedback, see Figure 4

This configuration is most popular in counters and on-chip state-machine designs. The flip-flop inputs are defined by the device inputs and flip-flop outputs. Under this condition, the period is limited by the internal delay from the flip-flop outputs through the internal feedback and logic array to the inputs of the next flip-flop.

$$\text{Thus, } f_{\max} \text{ with internal feedback} = \frac{1}{(t_{su} + t_{pd} \text{ CLK-to-FB})}$$

Where $t_{pd} \text{ CLK-to-FB}$ is the deduced value of the delay from CLK to the input of the logic array.

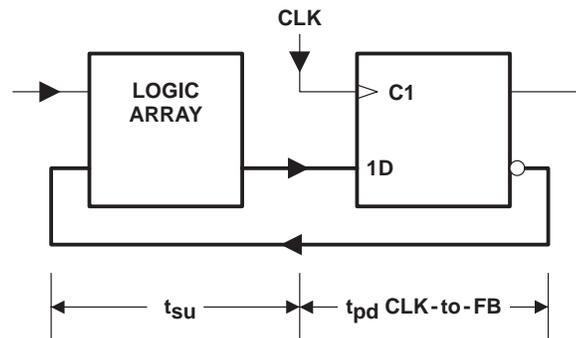

Figure 4. f_{\max} With Internal Feedback

f_{max} SPECIFICATIONS

f_{max} with external feedback, see Figure 5

This configuration is a typical state-machine design with feedback signals sent off-chip. This external feedback could go back to the device inputs or to a second device in a multi-chip state machine. The slowest path defining the period is the sum of the clock-to-output time and the input setup time for the external signals ($t_{su} + t_{pd \text{ CLK-to-Q}}$).

$$\text{Thus, } f_{\text{max}} \text{ with external feedback} = \frac{1}{(t_{\text{su}} + t_{\text{pd CLK-to-Q}})}$$

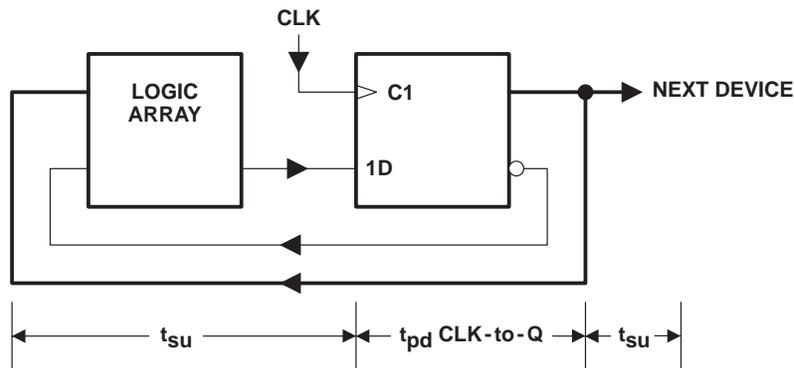
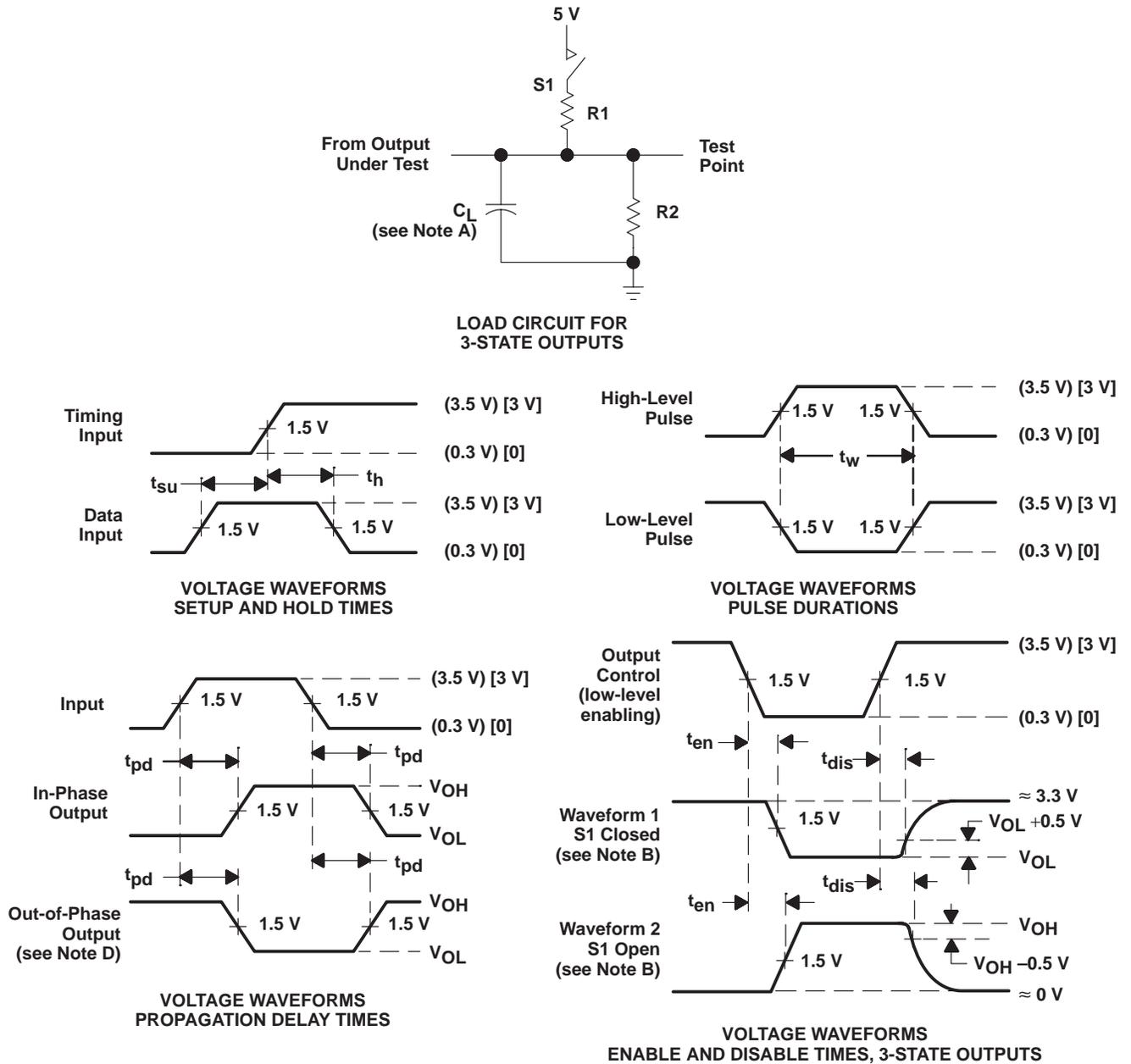

Figure 5. f_{max} With External Feedback

PARAMETER MEASUREMENT INFORMATION



- NOTES: A. C_L includes probe and jig capacitance and is 50 pF for t_{pd} and t_{en} , 5 pF for t_{dis} .
B. Waveform 1 is for an output with internal conditions such that the output is low except when disabled by the output control. Waveform 2 is for an output with internal conditions such that the output is high except when disabled by the output control.
C. All input pulses have the following characteristics: For C suffix, use the voltage levels indicated in parentheses (), PRR \leq 1 MHz, $t_r = t_f = 2$ ns, duty cycle = 50%; For M suffix, use the voltage levels indicated in brackets [], PRR \leq 10 MHz, t_r and $t_f \leq 2$ ns, duty cycle = 50%
D. When measuring propagation delay times of 3-state outputs, switch S1 is closed.
E. Equivalent loads may be used for testing.

Figure 6. Load Circuit and Voltage Waveforms

TIBPAL16L8-7C, TIBPAL16R4-7C, TIBPAL16R6-7C, TIBPAL16R8-7C
 TIBPAL16L8-10M, TIBPAL16R4-10M, TIBPAL16R6-10M, TIBPAL16R8-10M
 HIGH-PERFORMANCE *IMPACT-X*[™] *PAL*[®] CIRCUITS
 SRPS006D – D3115, MAY 1988 – REVISED MARCH 1992

TYPICAL CHARACTERISTICS

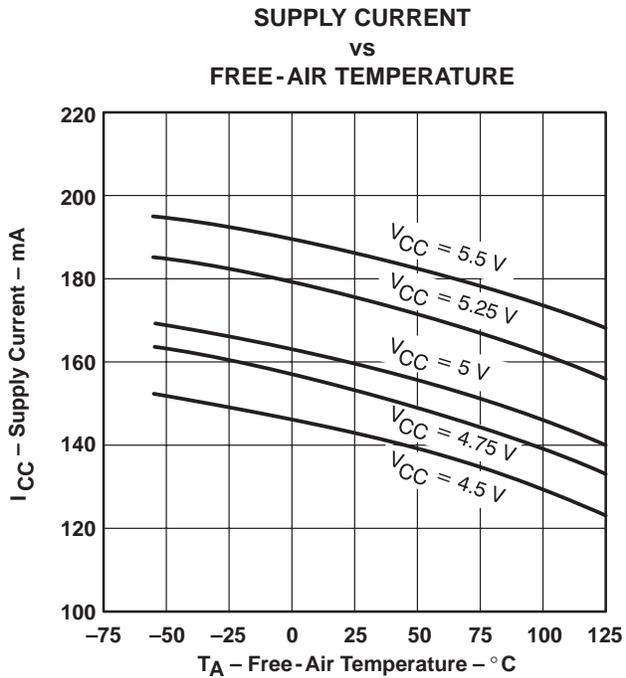

Figure 7

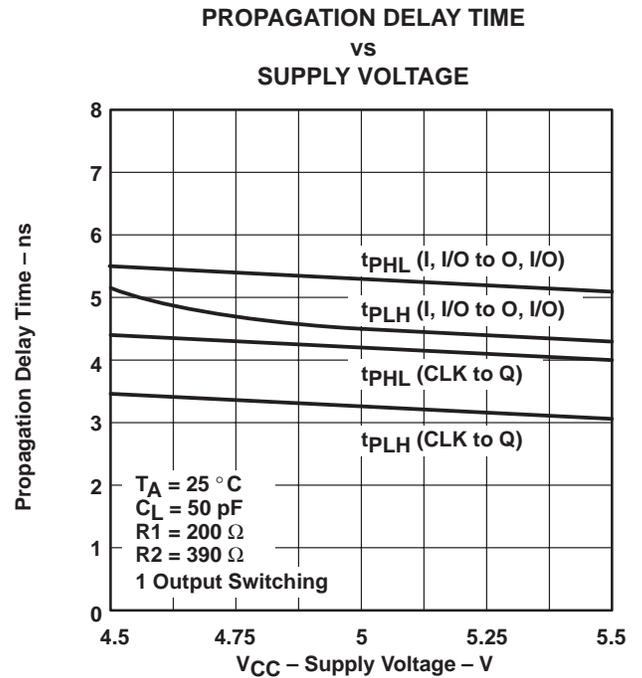

Figure 8

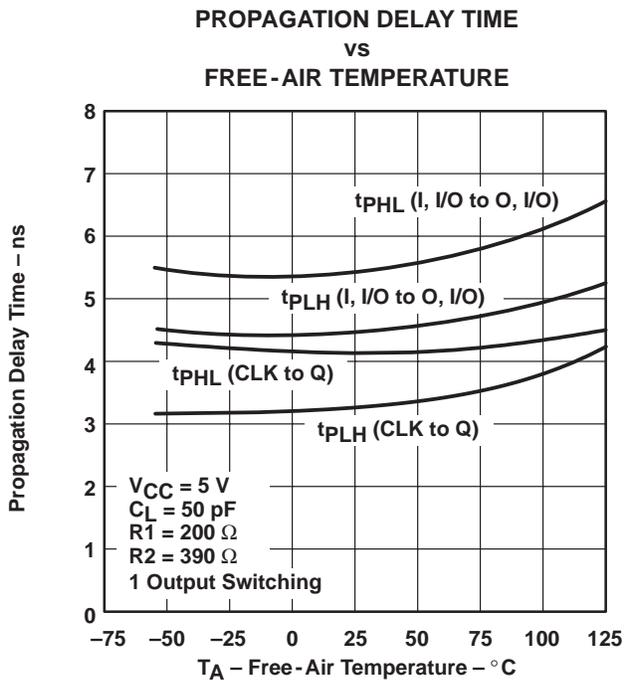

Figure 9

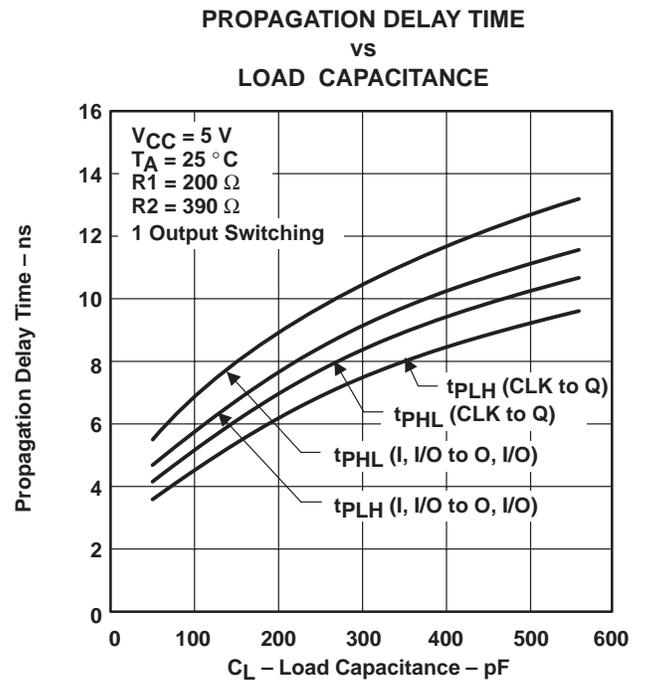

Figure 10

TIBPAL16L8-7C, TIBPAL16R4-7C, TIBPAL16R6-7C, TIBPAL16R8-7C
 TIBPAL16L8-10M, TIBPAL16R4-10M, TIBPAL16R6-10M, TIBPAL16R8-10M
 HIGH-PERFORMANCE *IMPACT-X*[™] PAL[®] CIRCUITS
 SRPS006D – D3115, MAY 1988 – REVISED MARCH 1992

TYPICAL CHARACTERISTICS

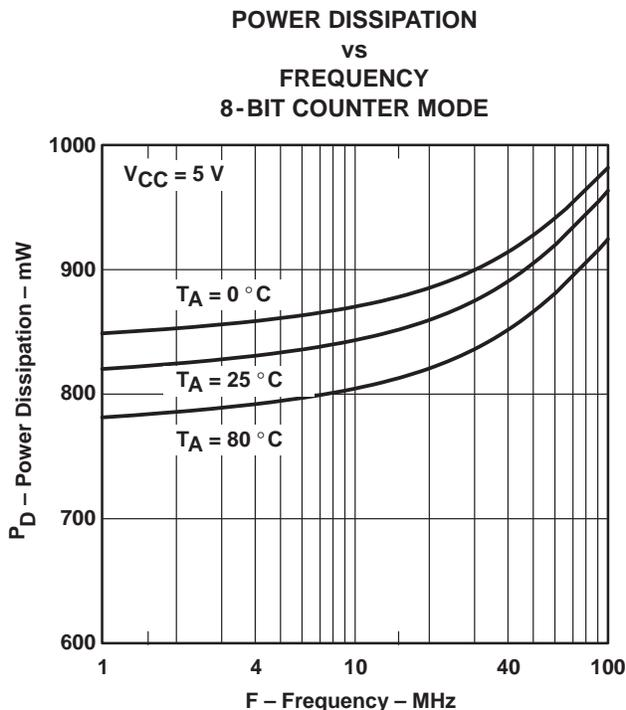

Figure 11

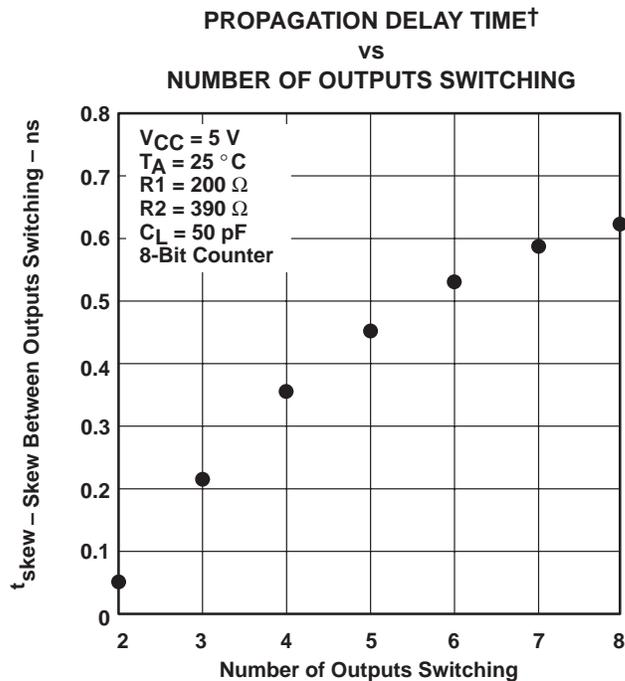

Figure 12

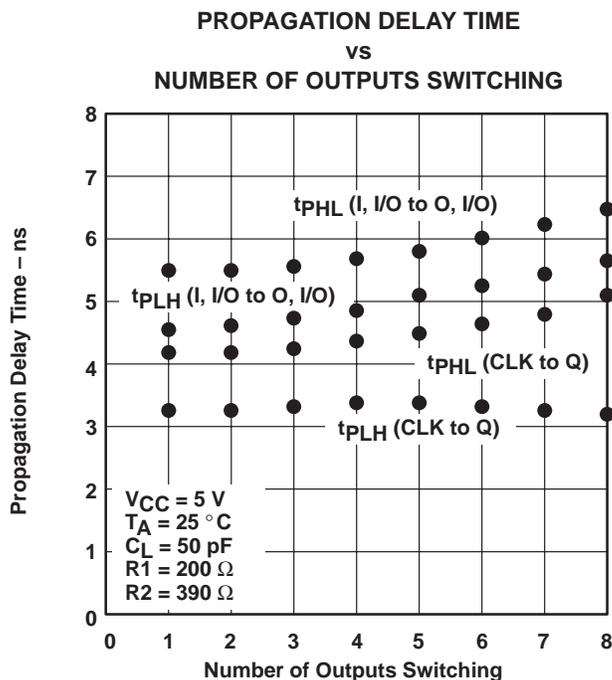

Figure 13

[†]Outputs switching in the same direction (t_{PLH} compared to $t_{\text{PLH}}/t_{\text{PHL}}$ to t_{PHL})

TI North American Sales Offices

ALABAMA: Huntsville: (205) 837-7530
ARIZONA: Phoenix: (602) 995-1007
CALIFORNIA: Irvine: (714) 660-1200
 San Diego: (619) 278-9600
 Santa Clara: (408) 980-9000
 Woodland Hills: (818) 704-8100
COLORADO: Aurora: (303) 368-8000
CONNECTICUT: Wallingford: (203) 269-0074
FLORIDA: Altamonte Springs: (407) 260-2116
 Fort Lauderdale: (305) 973-8502
 Tampa: (813) 885-7588
GEORGIA: Norcross: (404) 662-7967
ILLINOIS: Arlington Heights: (708) 640-3000
INDIANA: Carmel: (317) 573-6400
 Fort Wayne: (219) 489-4697
KANSAS: Overland Park: (913) 451-4511
MARYLAND: Columbia: (410) 964-2003
MASSACHUSETTS: Waltham: (617) 895-9100
MICHIGAN: Farmington Hills: (313) 553-1581
MINNESOTA: Eden Prairie: (612) 828-9300
MISSOURI: St. Louis: (314) 821-8400
NEW JERSEY: Iselin: (908) 750-1050
NEW MEXICO: Albuquerque: (505) 345-2555
NEW YORK: East Syracuse: (315) 463-9291
 Fishkill: (914) 897-2900
 Melville: (516) 454-6600
 Pittsford: (716) 385-6770
NORTH CAROLINA: Charlotte: (704) 527-0930
 Raleigh: (919) 876-2725
OHIO: Beachwood: (216) 765-7258
 Beavercreek: (513) 427-6200
OREGON: Beaverton: (503) 643-6758
PENNSYLVANIA: Blue Bell: (215) 825-9500
PUERTO RICO: Hato Rey: (809) 753-8700
TEXAS: Austin: (512) 250-6769
 Dallas: (214) 917-1264
 Houston: (713) 778-6592
 Midland: (915) 561-7137
UTAH: Salt Lake City: (801) 466-8972
WISCONSIN: Waukesha: (414) 798-1001
CANADA: Nepean: (613) 726-1970
 Richmond Hill: (416) 884-9181
 St. Laurent: (514) 335-8392

TI Regional Technology Centers

CALIFORNIA: Irvine: (714) 660-8140
 Santa Clara: (408) 748-2222
GEORGIA: Norcross: (404) 662-7945
ILLINOIS: Arlington Heights: (708) 640-2909
INDIANA: Indianapolis: (317) 573-6400
MASSACHUSETTS: Waltham: (617) 895-9196
MEXICO: Mexico City: 491-70834
MINNESOTA: Minneapolis: (612) 828-9300
TEXAS: Dallas: (214) 917-3881
CANADA: Nepean: (613) 726-1970

Customer Response Center

TOLL FREE: (800) 336-5236
OUTSIDE USA: (214) 995-6611
 (8:00 a.m. – 5:00 p.m. CST)

TI Authorized North American Distributors

Alliance Electronics, Inc. (military product only)
 Almac/Arrow
 Anthem Electronics
 Arrow/Schweber
 Future Electronics (Canada)
 GRS Electronics Co., Inc.
 Hall-Mark Electronics
 Marshall Industries
 Newark Electronics
 Rochester Electronics, Inc.
 (obsolete product only) (508) 462-9332
 Wyle Laboratories
 Zeus Components

TI Distributors

ALABAMA: Arrow/Schweber (205) 837-6955; Hall-Mark (205) 837-8700; Marshall (205) 881-9235.
ARIZONA: Anthem (602) 966-6600; Arrow/Schweber (602) 437-0750; Hall-Mark (602) 431-0030; Marshall (602) 496-0290; Wyle (602) 437-2088.
CALIFORNIA: Los Angeles/Orange County: Anthem (818) 775-1333, (714) 768-4444; Arrow/Schweber (818) 380-9686, (714) 838-5422; Hall-Mark (818) 773-4500, (714) 727-6000; Marshall (818) 878-7000, (714) 458-5301; Wyle (818) 880-9000, (714) 863-9953; Zeus (714) 921-9000, (818) 889-3838;
Sacramento: Anthem (916) 624-9744; Hall-Mark (916) 624-9781; Marshall (916) 635-9700; Wyle (916) 638-5282;
San Diego: Anthem (619) 453-9005; Arrow/Schweber (619) 565-4800; Hall-Mark (619) 268-1201; Marshall (619) 578-9600; Wyle (619) 565-9171; Zeus (619) 277-9681.
San Francisco Bay Area: Anthem (408) 453-1200; Arrow/Schweber (408) 441-9700, (510) 490-9477; Hall-Mark (408) 432-4000; Marshall (408) 942-4600; Wyle (408) 727-2500; Zeus (408) 629-4789.
COLORADO: Anthem (303) 790-4500; Arrow/Schweber (303) 799-0258; Hall-Mark (303) 790-1662; Marshall (303) 451-8383; Wyle (303) 457-9953.
CONNECTICUT: Anthem (203) 575-1575; Arrow/Schweber (203) 265-7741; Hall-Mark (203) 271-2844; Marshall (203) 265-3822.
FLORIDA: Fort Lauderdale: Arrow/Schweber (305) 429-8200; Hall-Mark (305) 971-9280; Marshall (305) 977-4880.
Orlando: Arrow/Schweber (407) 333-9300; Hall-Mark (407) 830-5855; Marshall (407) 767-8585; Zeus (407) 788-9100.
Tampa: Hall-Mark (813) 541-7440; Marshall (813) 573-1399.
GEORGIA: Arrow/Schweber (404) 497-1300; Hall-Mark (404) 623-4400; Marshall (404) 923-5750.
ILLINOIS: Anthem (708) 884-0200; Arrow/Schweber (708) 250-0500; Hall-Mark (312) 860-3800; Marshall (708) 490-0155; Newark (312) 784-5100.
INDIANA: Arrow/Schweber (317) 299-2071; Hall-Mark (317) 872-8875; Marshall (317) 297-0483.
IOWA: Arrow/Schweber (319) 395-7230.
KANSAS: Arrow/Schweber (913) 541-9542; Hall-Mark (913) 888-4747; Marshall (913) 492-3121.
MARYLAND: Anthem (301) 995-6640; Arrow/Schweber (301) 596-7800; Hall-Mark (301) 988-9800; Marshall (301) 622-1118; Zeus (301) 997-1118.
MASSACHUSETTS: Anthem (508) 657-5170; Arrow/Schweber (508) 658-0900; Hall-Mark (508) 667-0902; Marshall (508) 658-0810; Wyle (617) 272-7300; Zeus (617) 246-8200.

MICHIGAN: Detroit: Arrow/Schweber (313) 462-2290; Hall-Mark (313) 416-5800; Marshall (313) 525-5850; Newark (313) 967-0600.
MINNESOTA: Anthem (612) 944-5454; Arrow/Schweber (612) 941-5280; Hall-Mark (612) 881-2600; Marshall (612) 559-2211.
MISSOURI: Arrow/Schweber (314) 567-6888; Hall-Mark (314) 291-5350; Marshall (314) 291-4650.
NEW JERSEY: Anthem (201) 227-7960; Arrow/Schweber (201) 227-7880, (609) 596-8000; Hall-Mark (201) 515-3000, (609) 235-1900; Marshall (201) 882-0320, (609) 234-9100.
NEW MEXICO: Alliance (505) 292-3360.
NEW YORK: Long Island: Anthem (516) 864-6600; Arrow/Schweber (516) 231-1000; Hall-Mark (516) 737-0600; Marshall (516) 273-2424; Zeus (914) 937-7400.
Rochester: Arrow/Schweber (716) 427-0300; Hall-Mark (716) 425-3300; Marshall (716) 235-7620.
Syracuse: Marshall (607) 785-2345.
NORTH CAROLINA: Arrow/Schweber (919) 876-3132; Hall-Mark (919) 872-0712; Marshall (919) 878-9882.
OHIO: Cleveland: Arrow/Schweber (216) 248-3990; Hall-Mark (216) 349-4632; Marshall (216) 248-1788.
Columbus: Hall-Mark (614) 888-3313.
Dayton: Arrow/Schweber (513) 435-5563; Marshall (513) 898-4480; Zeus (513) 293-6162.
OKLAHOMA: Arrow/Schweber (918) 252-7537; Hall-Mark (918) 254-6110.
OREGON: Almac/Arrow (503) 629-8090; Anthem (503) 643-1114; Marshall (503) 644-5050; Wyle (503) 643-7900.
PENNSYLVANIA: Anthem (215) 443-5150; Arrow/Schweber (215) 928-1800; GRS (215) 922-7037; (609) 964-8560; Marshall (412) 788-0441.
TEXAS: Austin: Arrow/Schweber (512) 835-4180; Hall-Mark (512) 258-8848; Marshall (512) 837-1991; Wyle (512) 345-8853;
Dallas: Anthem (214) 238-7100; Arrow/Schweber (214) 380-6464; Hall-Mark (214) 553-4300; Marshall (214) 233-5200; Wyle (214) 235-9953; Zeus (214) 783-7010;
Houston: Arrow/Schweber (713) 530-4700; Hall-Mark (713) 781-6100; Marshall (713) 467-1666; Wyle (713) 879-9953.
UTAH: Anthem (801) 973-8555; Arrow/Schweber (801) 973-6913; Marshall (801) 973-2288; Wyle (801) 974-9953.
WASHINGTON: Almac/Arrow (206) 643-9992; Anthem (206) 483-1700; Marshall (206) 486-5747; Wyle (206) 881-1150.
WISCONSIN: Arrow/Schweber (414) 792-0150; Hall-Mark (414) 797-7844; Marshall (414) 797-8400.
CANADA: Calgary: Future (403) 233-5325;
Edmonton: Future (403) 438-2858;
Montreal: Arrow/Schweber (514) 421-7411; Future (514) 694-7710; Marshall (514) 694-8142
Ottawa: Arrow/Schweber (613) 226-6903; Future (613) 820-8313.
Quebec: Future (418) 897-6666.
Toronto: Arrow/Schweber (416) 670-7769; Future (416) 612-9200; Marshall (416) 458-8046.
Vancouver: Arrow/Schweber (604) 421-2333; Future (604) 294-1166.

TI Die Processors

Chip Supply (407) 298-7100
 Elmo Semiconductor (818) 768-7400
 Minco Technology Labs (512) 834-2022



PACKAGING INFORMATION

Orderable Device	Status ⁽¹⁾	Package Type	Package Drawing	Pins	Package Qty	Eco Plan ⁽²⁾	Lead/Ball Finish	MSL Peak Temp ⁽³⁾
5962-85155172A	ACTIVE	LCCC	FK	20	1	None	Call TI	Level-NC-NC-NC
5962-8515517RA	ACTIVE	CDIP	J	20	1	None	Call TI	Level-NC-NC-NC
5962-8515517SA	ACTIVE	CFP	W	20	1	None	Call TI	Level-NC-NC-NC
5962-85155182A	ACTIVE	LCCC	FK	20	1	None	Call TI	Level-NC-NC-NC
5962-8515518RA	ACTIVE	CDIP	J	20	1	None	Call TI	Level-NC-NC-NC
5962-8515518SA	ACTIVE	CFP	W	20	1	None	Call TI	Level-NC-NC-NC
5962-85155192A	ACTIVE	LCCC	FK	20	1	None	Call TI	Level-NC-NC-NC
5962-8515519RA	ACTIVE	CDIP	J	20	1	None	Call TI	Level-NC-NC-NC
5962-8515519SA	ACTIVE	CFP	W	20	1	None	Call TI	Level-NC-NC-NC
5962-85155202A	LIFEBUY	LCCC	FK	20	1	None	Call TI	Level-NC-NC-NC
5962-8515520RA	LIFEBUY	CDIP	J	20	1	None	Call TI	Level-NC-NC-NC
5962-8515520SA	LIFEBUY	CFP	W	20	1	None	Call TI	Level-NC-NC-NC
TIBPAL16L8-10MFKB	ACTIVE	LCCC	FK	20	1	None	Call TI	Level-NC-NC-NC
TIBPAL16L8-10MJB	ACTIVE	CDIP	J	20	1	None	Call TI	Level-NC-NC-NC
TIBPAL16L8-10MWB	ACTIVE	CFP	W	20	1	None	Call TI	Level-NC-NC-NC
TIBPAL16L8-7CFN	ACTIVE	PLCC	FN	20	46	None	Call TI	Level-1-220-UNLIM
TIBPAL16L8-7CN	ACTIVE	PDIP	N	20	20	None	Call TI	Level-NC-NC-NC
TIBPAL16R4-10MFKB	LIFEBUY	LCCC	FK	20	1	None	Call TI	Level-NC-NC-NC
TIBPAL16R4-10MJB	LIFEBUY	CDIP	J	20	1	None	Call TI	Level-NC-NC-NC
TIBPAL16R4-10MWB	LIFEBUY	CFP	W	20	1	None	Call TI	Level-NC-NC-NC
TIBPAL16R4-7CFN	OBSOLETE	PLCC	FN	20		None	Call TI	Call TI
TIBPAL16R4-7CN	OBSOLETE	PDIP	N	20		None	Call TI	Call TI
TIBPAL16R6-10MFKB	ACTIVE	LCCC	FK	20	1	None	Call TI	Level-NC-NC-NC
TIBPAL16R6-10MJB	ACTIVE	CDIP	J	20	1	None	Call TI	Level-NC-NC-NC
TIBPAL16R6-10MWB	ACTIVE	CFP	W	20	1	None	Call TI	Level-NC-NC-NC
TIBPAL16R6-7CFN	ACTIVE	PLCC	FN	20	46	None	Call TI	Level-1-220-UNLIM
TIBPAL16R6-7CN	NRND	PDIP	N	20	20	None	Call TI	Level-NC-NC-NC
TIBPAL16R8-10MFKB	ACTIVE	LCCC	FK	20	1	None	Call TI	Level-NC-NC-NC
TIBPAL16R8-10MJB	ACTIVE	CDIP	J	20	1	None	Call TI	Level-NC-NC-NC
TIBPAL16R8-10MWB	ACTIVE	CFP	W	20	1	None	Call TI	Level-NC-NC-NC
TIBPAL16R8-7CFN	OBSOLETE	PLCC	FN	20		None	Call TI	Call TI
TIBPAL16R8-7CN	OBSOLETE	PDIP	N	20		None	Call TI	Call TI

⁽¹⁾ The marketing status values are defined as follows:

ACTIVE: Product device recommended for new designs.

LIFEBUY: TI has announced that the device will be discontinued, and a lifetime-buy period is in effect.

NRND: Not recommended for new designs. Device is in production to support existing customers, but TI does not recommend using this part in a new design.

PREVIEW: Device has been announced but is not in production. Samples may or may not be available.

OBSOLETE: TI has discontinued the production of the device.

⁽²⁾ Eco Plan - May not be currently available - please check <http://www.ti.com/productcontent> for the latest availability information and additional product content details.

None: Not yet available Lead (Pb-Free).

Pb-Free (RoHS): TI's terms "Lead-Free" or "Pb-Free" mean semiconductor products that are compatible with the current RoHS requirements for all 6 substances, including the requirement that lead not exceed 0.1% by weight in homogeneous materials. Where designed to be soldered

at high temperatures, TI Pb-Free products are suitable for use in specified lead-free processes.

Green (RoHS & no Sb/Br): TI defines "Green" to mean "Pb-Free" and in addition, uses package materials that do not contain halogens, including bromine (Br) or antimony (Sb) above 0.1% of total product weight.

⁽³⁾ MSL, Peak Temp. -- The Moisture Sensitivity Level rating according to the JEDEC industry standard classifications, and peak solder temperature.

Important Information and Disclaimer: The information provided on this page represents TI's knowledge and belief as of the date that it is provided. TI bases its knowledge and belief on information provided by third parties, and makes no representation or warranty as to the accuracy of such information. Efforts are underway to better integrate information from third parties. TI has taken and continues to take reasonable steps to provide representative and accurate information but may not have conducted destructive testing or chemical analysis on incoming materials and chemicals. TI and TI suppliers consider certain information to be proprietary, and thus CAS numbers and other limited information may not be available for release.

In no event shall TI's liability arising out of such information exceed the total purchase price of the TI part(s) at issue in this document sold by TI to Customer on an annual basis.

IMPORTANT NOTICE

Texas Instruments Incorporated and its subsidiaries (TI) reserve the right to make corrections, modifications, enhancements, improvements, and other changes to its products and services at any time and to discontinue any product or service without notice. Customers should obtain the latest relevant information before placing orders and should verify that such information is current and complete. All products are sold subject to TI's terms and conditions of sale supplied at the time of order acknowledgment.

TI warrants performance of its hardware products to the specifications applicable at the time of sale in accordance with TI's standard warranty. Testing and other quality control techniques are used to the extent TI deems necessary to support this warranty. Except where mandated by government requirements, testing of all parameters of each product is not necessarily performed.

TI assumes no liability for applications assistance or customer product design. Customers are responsible for their products and applications using TI components. To minimize the risks associated with customer products and applications, customers should provide adequate design and operating safeguards.

TI does not warrant or represent that any license, either express or implied, is granted under any TI patent right, copyright, mask work right, or other TI intellectual property right relating to any combination, machine, or process in which TI products or services are used. Information published by TI regarding third-party products or services does not constitute a license from TI to use such products or services or a warranty or endorsement thereof. Use of such information may require a license from a third party under the patents or other intellectual property of the third party, or a license from TI under the patents or other intellectual property of TI.

Reproduction of information in TI data books or data sheets is permissible only if reproduction is without alteration and is accompanied by all associated warranties, conditions, limitations, and notices. Reproduction of this information with alteration is an unfair and deceptive business practice. TI is not responsible or liable for such altered documentation.

Resale of TI products or services with statements different from or beyond the parameters stated by TI for that product or service voids all express and any implied warranties for the associated TI product or service and is an unfair and deceptive business practice. TI is not responsible or liable for any such statements.

Following are URLs where you can obtain information on other Texas Instruments products and application solutions:

Products		Applications	
Amplifiers	amplifier.ti.com	Audio	www.ti.com/audio
Data Converters	dataconverter.ti.com	Automotive	www.ti.com/automotive
DSP	dsp.ti.com	Broadband	www.ti.com/broadband
Interface	interface.ti.com	Digital Control	www.ti.com/digitalcontrol
Logic	logic.ti.com	Military	www.ti.com/military
Power Mgmt	power.ti.com	Optical Networking	www.ti.com/opticalnetwork
Microcontrollers	microcontroller.ti.com	Security	www.ti.com/security
		Telephony	www.ti.com/telephony
		Video & Imaging	www.ti.com/video
		Wireless	www.ti.com/wireless

Mailing Address: Texas Instruments
Post Office Box 655303 Dallas, Texas 75265