

# International IR Rectifier

PD -91783A

## IRG4BC20FD-S

INSULATED GATE BIPOLAR TRANSISTOR WITH  
ULTRAFAST SOFT RECOVERY DIODE

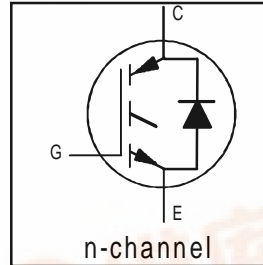
Fast CoPack IGBT

### Features

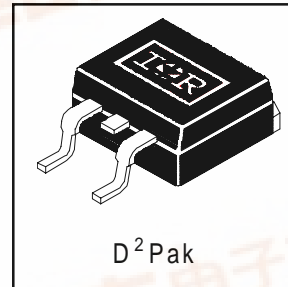
- Fast: Optimized for medium operating frequencies ( 1-5 kHz in hard switching, >20 kHz in resonant mode).
- Generation 4 IGBT design provides tighter parameter distribution and higher efficiency than Generation 3
- IGBT co-packaged with HEXFRED™ ultrafast, ultra-soft-recovery anti-parallel diodes for use in bridge configurations
- Industry standard D<sup>2</sup>Pak package

### Benefits

- Generation 4 IGBTs offer highest efficiencies available
- IGBTs optimized for specific application conditions
- HEXFRED diodes optimized for performance with IGBTs . Minimized recovery characteristics require less/no snubbing
- Designed to be a "drop-in" replacement for equivalent industry-standard Generation 3 IR IGBTs



|                                   |
|-----------------------------------|
| $V_{CES} = 600V$                  |
| $V_{CE(on)} \text{ typ.} = 1.66V$ |
| @ $V_{GE} = 15V, I_C = 9.0A$      |



### Absolute Maximum Ratings

|                           | Parameter                        | Max.        | Units      |
|---------------------------|----------------------------------|-------------|------------|
| $V_{CES}$                 | Collector-to-Emitter Voltage     | 600         | V          |
| $I_C @ T_C = 25^\circ C$  | Continuous Collector Current     | 16          | A          |
| $I_C @ T_C = 100^\circ C$ | Continuous Collector Current     | 9.0         |            |
| $I_{CM}$                  | Pulsed Collector Current ①       | 64          |            |
| $I_{LM}$                  | Clamped Inductive Load Current ② | 64          |            |
| $I_F @ T_C = 100^\circ C$ | Diode Continuous Forward Current | 8.0         |            |
| $I_{FM}$                  | Diode Maximum Forward Current    | 60          | V          |
| $V_{GE}$                  | Gate-to-Emitter Voltage          | $\pm 20$    |            |
| $P_D @ T_C = 25^\circ C$  | Maximum Power Dissipation        | 60          | W          |
| $P_D @ T_C = 100^\circ C$ | Maximum Power Dissipation        | 24          |            |
| $T_J$                     | Operating Junction and           | -55 to +150 | $^\circ C$ |
| $T_{STG}$                 | Storage Temperature Range        |             |            |

### Thermal Resistance

|                 | Parameter   | Typ. | Max. | Units        |
|-----------------|---|------|------|--------------|
| $R_{\theta JC}$ | Junction-to-Case - IGBT                           | —    | 2.1  | $^\circ C/W$ |
| $R_{\theta JC}$ | Junction-to-Case - Diode                          | —    | 3.5  |              |
| $R_{\theta JA}$ | Junction-to-Ambient ( PCB Mounted, steady-state)* | —    | 80   |              |
| Wt              | Weight  | 1.44 | —    | g (oz)       |

\* When mounted on 1" square PCB (FR-4 or G-10 Material ). For recommended footprint and soldering techniques refer to application note #AN-994.



# IRG4BC20FD-S

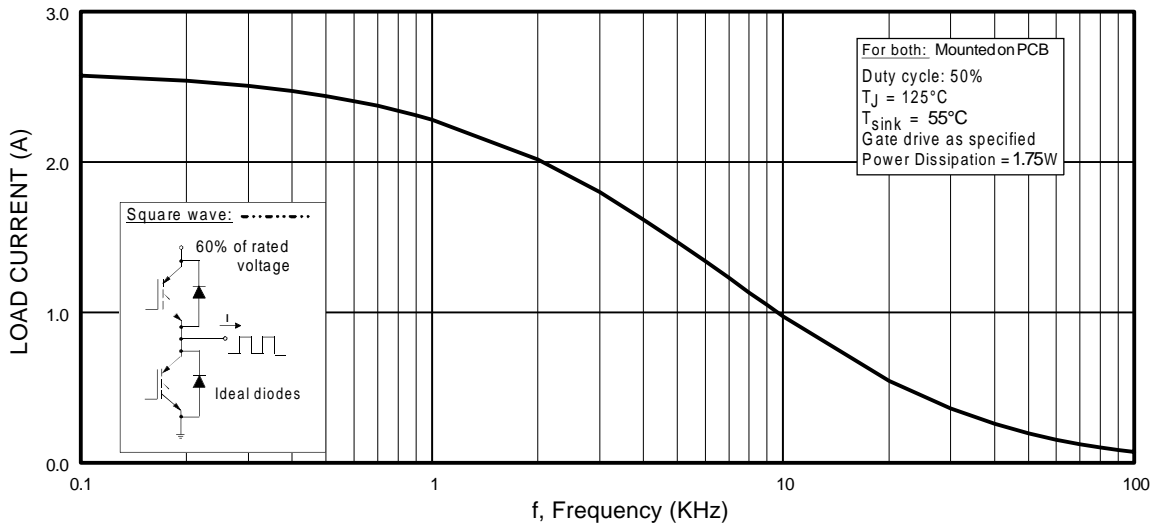
International  
**IRF** Rectifier

## Electrical Characteristics @ $T_J = 25^\circ\text{C}$ (unless otherwise specified)

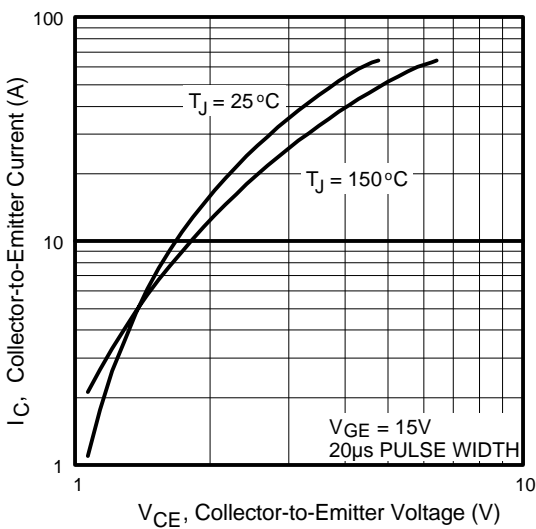
|                                 | Parameter   | Min. | Typ. | Max.      | Units                | Conditions  |
|---------------------------------|---|------|------|-----------|----------------------|---|
| $V_{(BR)CES}$                   | Collector-to-Emitter Breakdown Voltage <sup>③</sup> | 600  | —    | —         | V                    | $V_{GE} = 0V, I_C = 250\mu A$   |
| $\Delta V_{(BR)CES}/\Delta T_J$ | Temperature Coeff. of Breakdown Voltage             | —    | 0.72 | —         | V/ $^\circ\text{C}$  | $V_{GE} = 0V, I_C = 1.0mA$  |
| $V_{CE(on)}$                    | Collector-to-Emitter Saturation Voltage             | —    | 1.66 | 2.0       | V                    | $I_C = 9.0A$<br>$I_C = 16A$<br>$I_C = 9.0A, T_J = 150^\circ\text{C}$                  |
|                                 |   | —    | 2.06 | —         |                      |   |
|                                 |   | —    | 1.76 | —         |                      |   |
| $V_{GE(th)}$                    | Gate Threshold Voltage                              | 3.0  | —    | 6.0       |                      | $V_{CE} = V_{GE}, I_C = 250\mu A$   |
| $\Delta V_{GE(th)}/\Delta T_J$  | Temperature Coeff. of Threshold Voltage             | —    | -11  | —         | mV/ $^\circ\text{C}$ | $V_{CE} = V_{GE}, I_C = 250\mu A$   |
| $g_{fe}$                        | Forward Transconductance <sup>④</sup>               | 2.9  | 5.1  | —         | S                    | $V_{CE} = 100V, I_C = 9.0A$   |
| $I_{CES}$                       | Zero Gate Voltage Collector Current                 | —    | —    | 250       | $\mu A$              | $V_{GE} = 0V, V_{CE} = 600V$<br>$V_{GE} = 0V, V_{CE} = 600V, T_J = 150^\circ\text{C}$ |
|                                 |   | —    | —    | 1700      |                      |   |
| $V_{FM}$                        | Diode Forward Voltage Drop                          | —    | 1.4  | 1.7       | V                    | $I_C = 8.0A$<br>$I_C = 8.0A, T_J = 150^\circ\text{C}$                                 |
|                                 |   | —    | 1.3  | 1.6       |                      |   |
| $I_{GES}$                       | Gate-to-Emitter Leakage Current                     | —    | —    | $\pm 100$ | nA                   | $V_{GE} = \pm 20V$  |

## Switching Characteristics @ $T_J = 25^\circ\text{C}$ (unless otherwise specified)

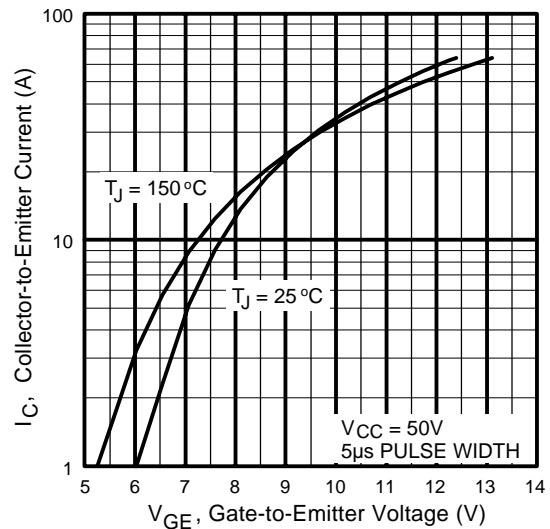
|                  | Parameter  | Min. | Typ. | Max. | Units      | Conditions   |
|------------------|--|------|------|------|------------|--|
| $Q_g$            | Total Gate Charge (turn-on)                      | —    | 27   | 40   | nC         | $I_C = 9.0A$<br>$V_{CC} = 400V$<br>$V_{GE} = 15V$<br>See Fig. 8  |
| $Q_{ge}$         | Gate - Emitter Charge (turn-on)                  | —    | 4.2  | 6.2  |            |  |
| $Q_{gc}$         | Gate - Collector Charge (turn-on)                | —    | 9.9  | 15   |            |  |
| $t_{d(on)}$      | Turn-On Delay Time                               | —    | 43   | —    | ns         | $T_J = 25^\circ\text{C}$<br>$I_C = 9.0A, V_{CC} = 480V$<br>$V_{GE} = 15V, R_G = 50\Omega$<br>Energy losses include "tail" and diode reverse recovery.<br>See Fig. 9, 10, 18  |
| $t_r$            | Rise Time  | —    | 20   | —    |            |  |
| $t_{d(off)}$     | Turn-Off Delay Time                              | —    | 240  | 360  |            |  |
| $t_f$            | Fall Time  | —    | 150  | 220  |            |  |
| $E_{on}$         | Turn-On Switching Loss                           | —    | 0.25 | —    | mJ         | $T_J = 150^\circ\text{C}$ , See Fig. 10, 11, 18<br>$I_C = 9.0A, V_{CC} = 480V$<br>$V_{GE} = 15V, R_G = 50\Omega$<br>Energy losses include "tail" and diode reverse recovery. |
| $E_{off}$        | Turn-Off Switching Loss                          | —    | 0.64 | —    |            |  |
| $E_{ts}$         | Total Switching Loss                             | —    | 0.89 | 1.3  |            |  |
| $t_{d(on)}$      | Turn-On Delay Time                               | —    | 41   | —    | ns         | $T_J = 150^\circ\text{C}$ , See Fig. 10, 11, 18<br>$I_C = 9.0A, V_{CC} = 480V$<br>$V_{GE} = 15V, R_G = 50\Omega$<br>Energy losses include "tail" and diode reverse recovery. |
| $t_r$            | Rise Time  | —    | 22   | —    |            |  |
| $t_{d(off)}$     | Turn-Off Delay Time                              | —    | 320  | —    |            |  |
| $t_f$            | Fall Time  | —    | 290  | —    |            |  |
| $E_{ts}$         | Total Switching Loss                             | —    | 1.35 | —    | mJ         |  |
| $L_E$            | Internal Emitter Inductance                      | —    | 7.5  | —    | nH         | Measured 5mm from package  |
| $C_{ies}$        | Input Capacitance                                | —    | 540  | —    | pF         | $V_{GE} = 0V$<br>$V_{CC} = 30V$<br>$f = 1.0MHz$<br>See Fig. 7  |
| $C_{oes}$        | Output Capacitance                               | —    | 37   | —    |            |  |
| $C_{res}$        | Reverse Transfer Capacitance                     | —    | 7.0  | —    |            |  |
| $t_{rr}$         | Diode Reverse Recovery Time                      | —    | 37   | 55   | ns         | $T_J = 25^\circ\text{C}$ See Fig. 14<br>$T_J = 125^\circ\text{C}$  |
|                  |  | —    | 55   | 90   |            |  |
| $I_{rr}$         | Diode Peak Reverse Recovery Current              | —    | 3.5  | 5.0  | A          | $T_J = 25^\circ\text{C}$ See Fig. 15<br>$T_J = 125^\circ\text{C}$  |
|                  |  | —    | 4.5  | 8.0  |            |  |
| $Q_{rr}$         | Diode Reverse Recovery Charge                    | —    | 65   | 138  | nC         | $T_J = 25^\circ\text{C}$ See Fig. 16<br>$T_J = 125^\circ\text{C}$  |
|                  |  | —    | 124  | 360  |            |  |
| $di_{(rec)M}/dt$ | Diode Peak Rate of Fall of Recovery During $t_b$ | —    | 240  | —    | A/ $\mu s$ | $T_J = 25^\circ\text{C}$ See Fig. 17<br>$T_J = 125^\circ\text{C}$  |
|                  |  | —    | 210  | —    |            |  |



**Fig. 1 - Typical Load Current vs. Frequency**  
(Load Current =  $I_{RMS}$  of fundamental)



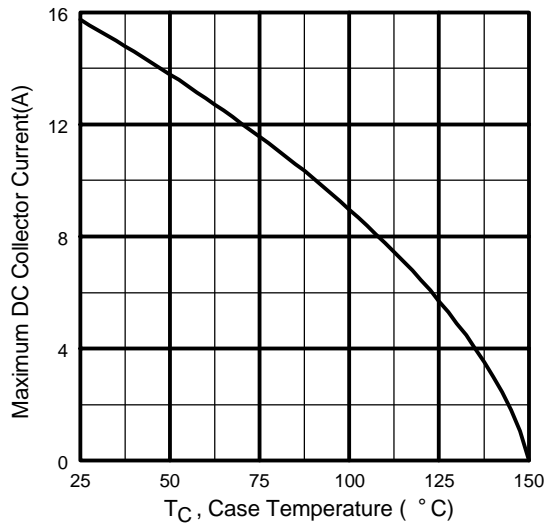
**Fig. 2 - Typical Output Characteristics**



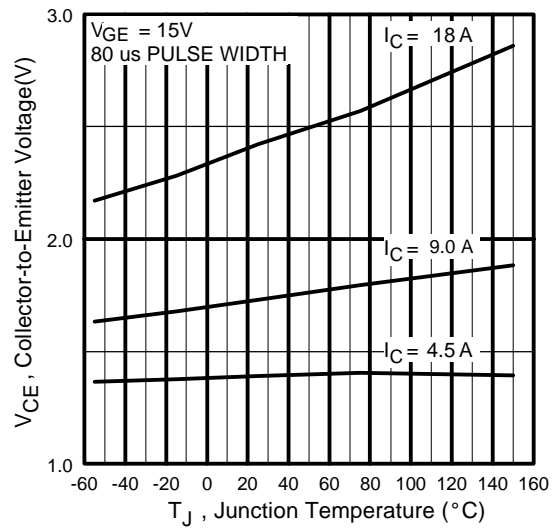
**Fig. 3 - Typical Transfer Characteristics**

# IRG4BC20FD-S

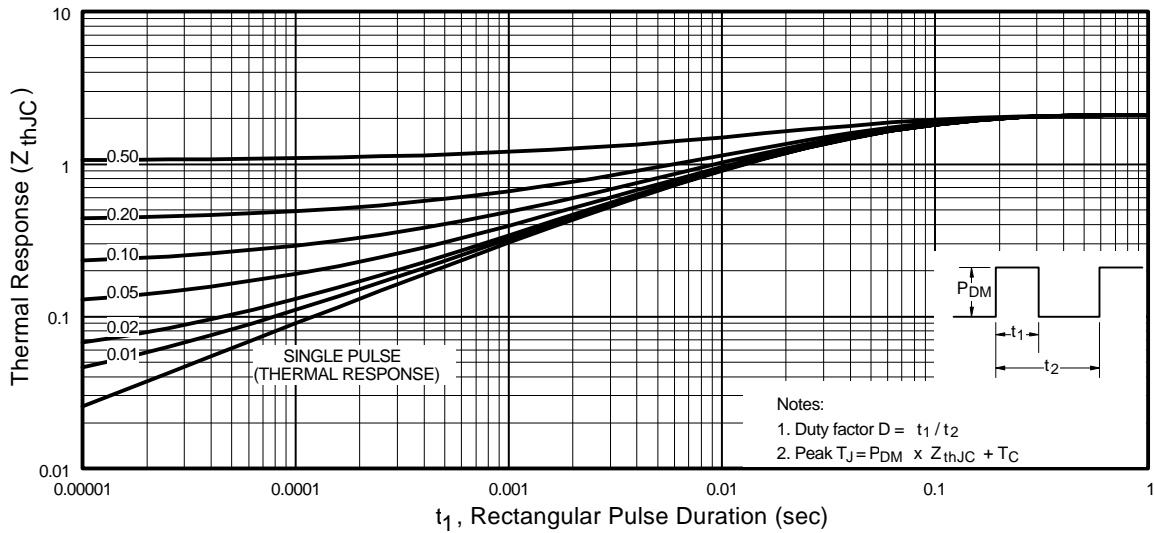
International  
**IRF** Rectifier



**Fig. 4** - Maximum Collector Current vs. Case Temperature

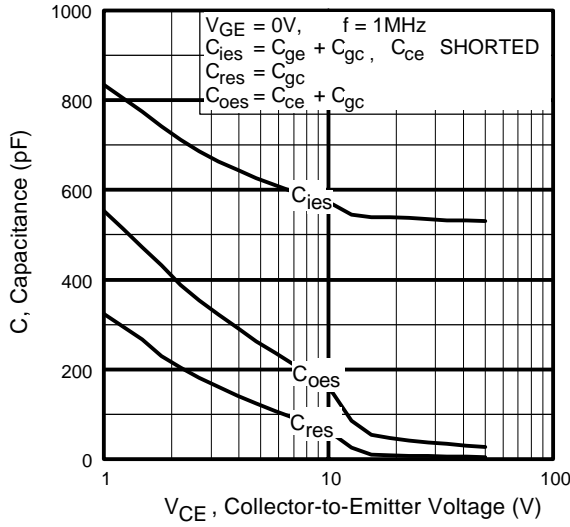


**Fig. 5** - Typical Collector-to-Emitter Voltage vs. Junction Temperature

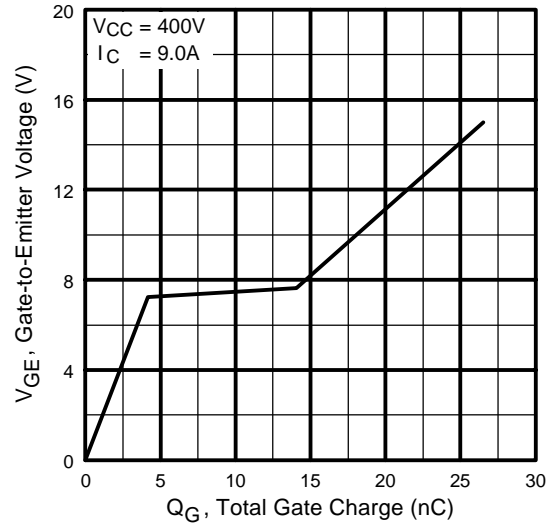


**Fig. 6** - Maximum Effective Transient Thermal Impedance, Junction-to-Case

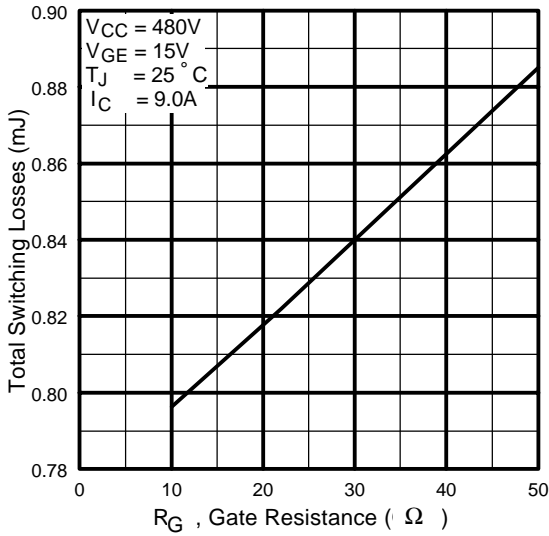
# IRG4BC20FD-S



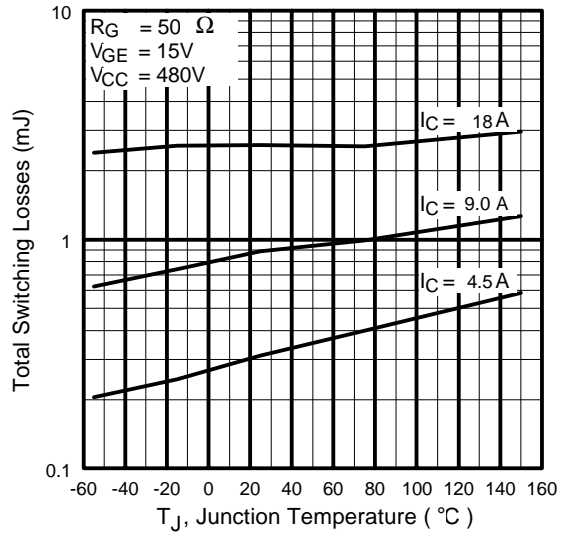
**Fig. 7** - Typical Capacitance vs. Collector-to-Emitter Voltage



**Fig. 8** - Typical Gate Charge vs. Gate-to-Emitter Voltage



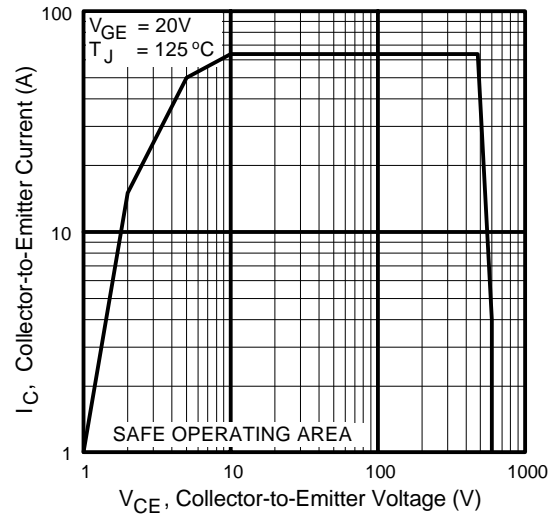
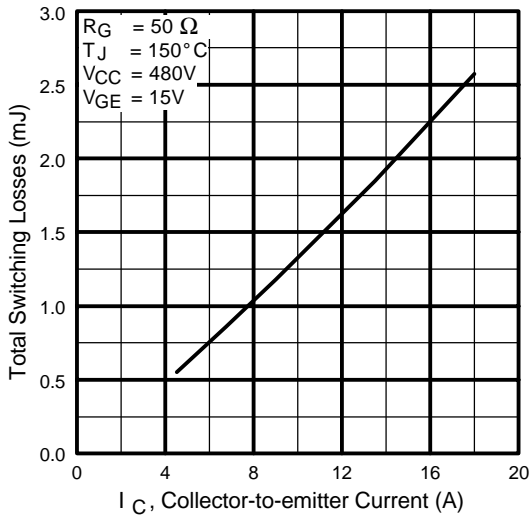
**Fig. 9** - Typical Switching Losses vs. Gate Resistance



**Fig. 10** - Typical Switching Losses vs. Junction Temperature

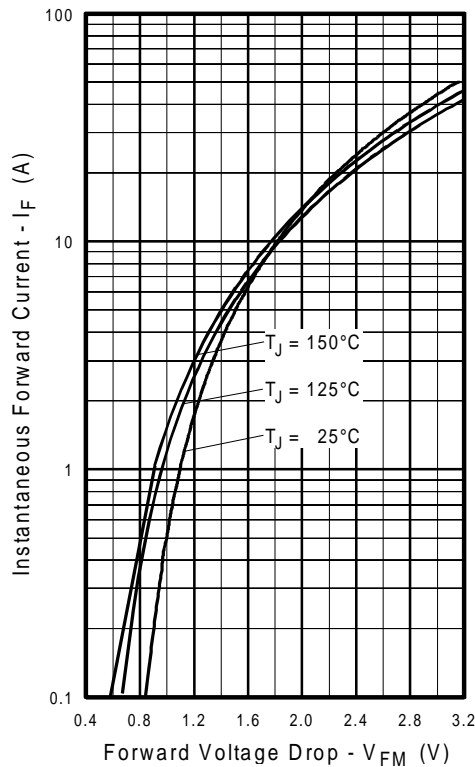
# IRG4BC20FD-S

International  
**IR** Rectifier



**Fig. 11** - Typical Switching Losses vs. Collector-to-emitter Current

**Fig. 12** - Turn-Off SOA



**Fig. 13** - Maximum Forward Voltage Drop vs. Instantaneous Forward Current

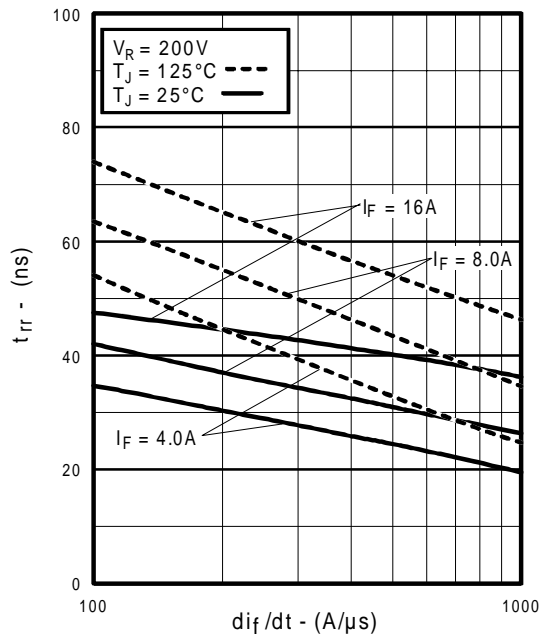


Fig. 14 - Typical Reverse Recovery vs.  $di_f/dt$

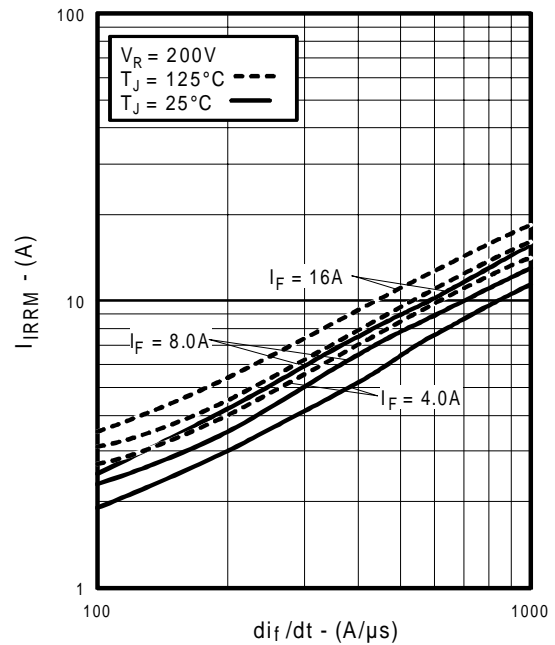


Fig. 15 - Typical Recovery Current vs.  $di_f/dt$

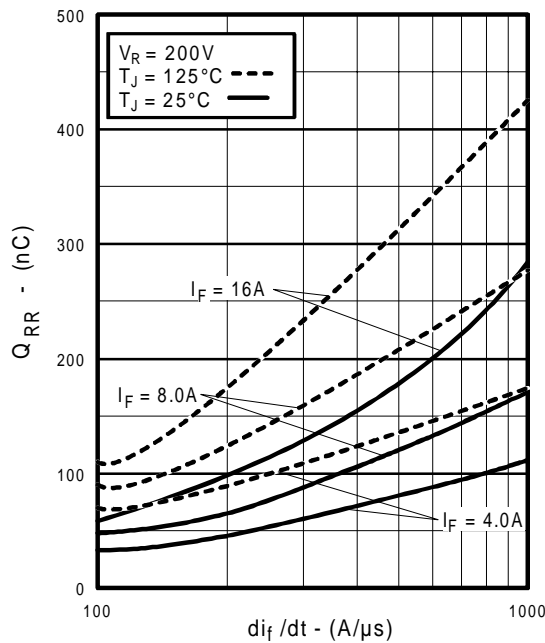


Fig. 16 - Typical Stored Charge vs.  $di_f/dt$

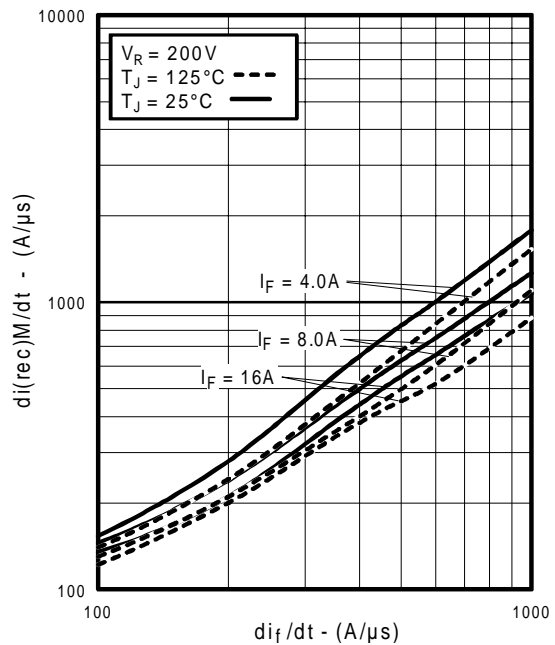
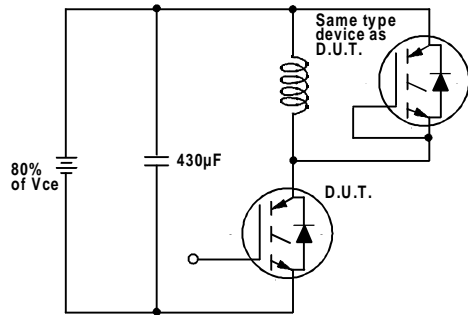
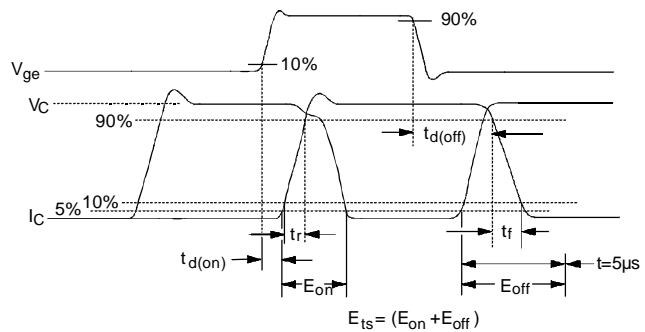


Fig. 17 - Typical  $di_{(rec)M}/dt$  vs.  $di_f/dt$

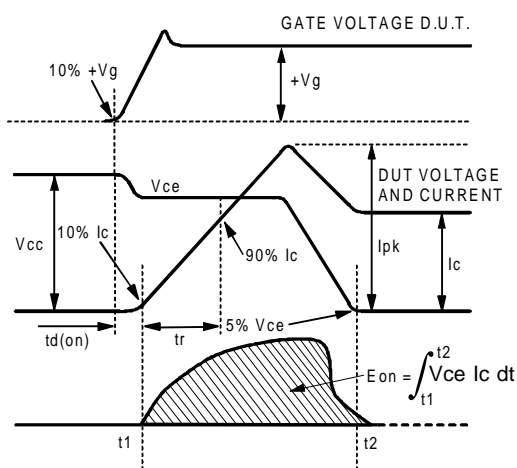
# IRG4BC20FD-S



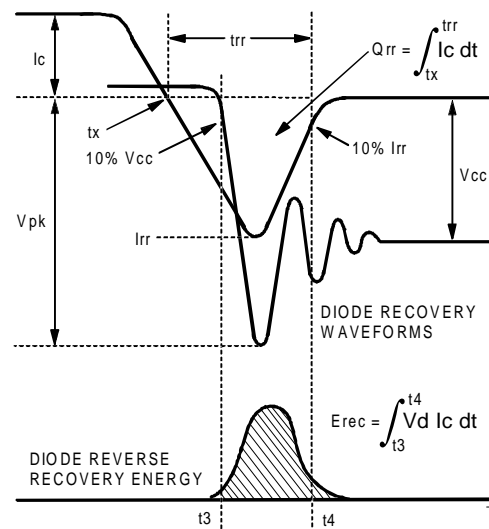
**Fig. 18a** - Test Circuit for Measurement of  $I_{LM}$ ,  $E_{on}$ ,  $E_{off}(\text{diode})$ ,  $t_{rr}$ ,  $Q_{rr}$ ,  $I_{rr}$ ,  $t_{d(on)}$ ,  $t_r$ ,  $t_{d(off)}$ ,  $t_f$



**Fig. 18b** - Test Waveforms for Circuit of Fig. 18a, Defining  $E_{off}$ ,  $t_{d(off)}$ ,  $t_f$



**Fig. 18c** - Test Waveforms for Circuit of Fig. 18a, Defining  $E_{on}$ ,  $t_{d(on)}$ ,  $t_r$



**Fig. 18d** - Test Waveforms for Circuit of Fig. 18a, Defining  $E_{rec}$ ,  $t_{rr}$ ,  $Q_{rr}$ ,  $I_{rr}$

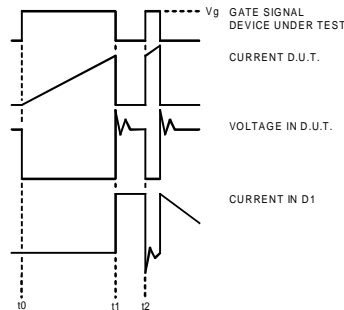


Figure 18e. Macro Waveforms for Figure 18a's Test Circuit

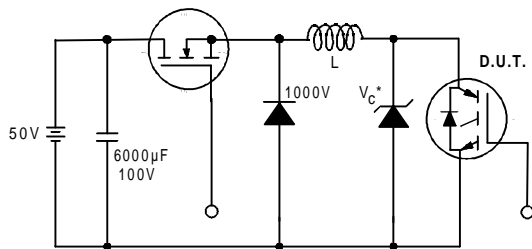


Figure 19. Clamped Inductive Load Test Circuit

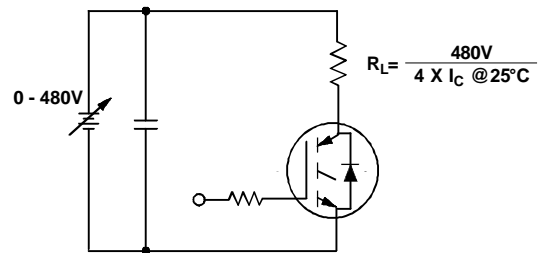
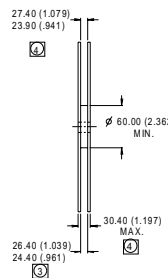
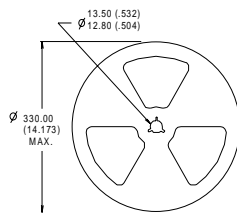
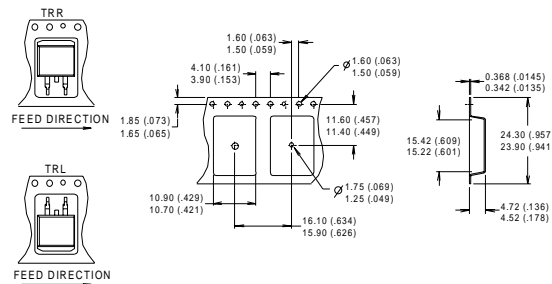


Figure 20. Pulsed Collector Current Test Circuit

## Tape & Reel Information

### D<sup>2</sup>Pak



- NOTES:  
 1. CONFORMS TO EIA-418.  
 2. CONTROLLING DIMENSION: MILLIMETER.  
 3. DIMENSION MEASURED @ HUB.  
 4. INCLUDES FLANGE DISTORTION @ OUTER EDGE.

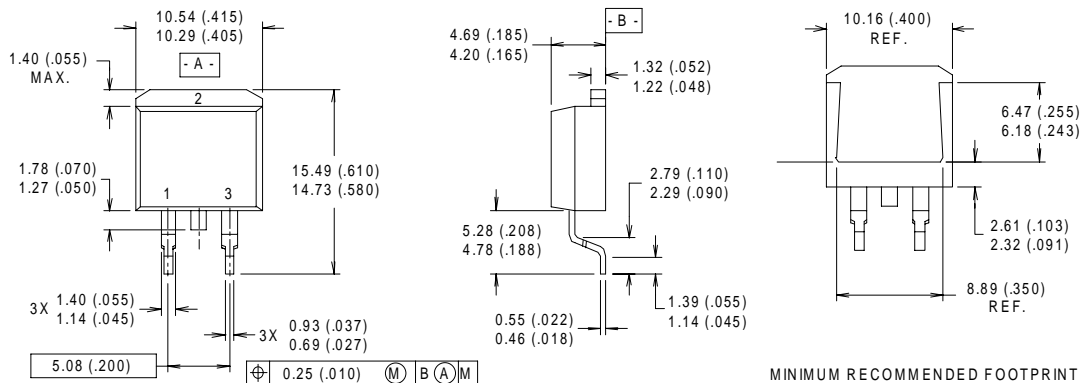
# IRG4BC20FD-S

International  
**IR** Rectifier

## Notes:

- ① Repetitive rating:  $V_{GE}=20V$ ; pulse width limited by maximum junction temperature (figure 20)
- ②  $V_{CC}=80\%(V_{CES})$ ,  $V_{GE}=20V$ ,  $L=10\mu H$ ,  $R_G = 50\Omega$  (figure 19)
- ③ Pulse width  $\leq 80\mu s$ ; duty factor  $\leq 0.1\%$ .
- ④ Pulse width  $5.0\mu s$ , single shot.

## D<sup>2</sup>Pak Package Outline



### NOTES:

- 1 DIMENSIONS AFTER SOLDER DIP.
- 2 DIMENSIONING & TOLERANCING PER ANSI Y14.5M, 1982.
- 3 CONTROLLING DIMENSION : INCH.
- 4 HEATSINK & LEAD DIMENSIONS DO NOT INCLUDE BURRS.

International  
**IR** Rectifier

**IR WORLD HEADQUARTERS:** 233 Kansas St., El Segundo, California 90245, USA Tel: (310) 252-7105  
**IR EUROPEAN REGIONAL CENTRE:** 439/445 Godstone Rd, Whyteleafe, Surrey CR3 OBL, UK Tel: ++ 44 (0)20 8645 8000  
**IR CANADA:** 15 Lincoln Court, Brampton, Ontario L6T3Z2, Tel: (905) 453 2200  
**IR GERMANY:** Saalburgstrasse 157, 61350 Bad Homburg Tel: ++ 49 (0) 6172 96590  
**IR ITALY:** Via Liguria 49, 10071 Borgaro, Torino Tel: ++ 39 011 451 0111  
**IR JAPAN:** K&H Bldg., 2F, 30-4 Nishi-Ikebukuro 3-Chome, Toshima-Ku, Tokyo 171 Tel: 81 (0)3 3983 0086  
**IR SOUTHEAST ASIA:** 1 Kim Seng Promenade, Great World City West Tower, 13-11, Singapore 237994 Tel: ++ 65 (0)838 4630  
**IR TAIWAN:** 16 Fl. Suite D. 207, Sec. 2, Tun Haw South Road, Taipei, 10673 Tel: 886-(0)2 2377 9936  
*Data and specifications subject to change without notice. 4/00*