

IS2701-1



**HIGH DENSITY MOUNTING
PHOTOTRANSISTOR
OPTICALLY COUPLED ISOLATORS**

DESCRIPTION

The IS2701-1 is an optically coupled isolator consisting of an infrared light emitting diode and NPN silicon photo transistor in a space efficient dual in line plastic package.

FEATURES

- Marked as FPT1.
- Current Transfer Ratio MIN. 50%
- Isolation Voltage (3.75kV_{RMS}, 5.3kV_{PK})
- All electrical parameters 100% tested
- Drop in replacement for NEC PS2701-1

APPLICATIONS

- Computer terminals
- Industrial systems controllers
- Measuring instruments
- Signal transmission between systems of different potentials and impedances

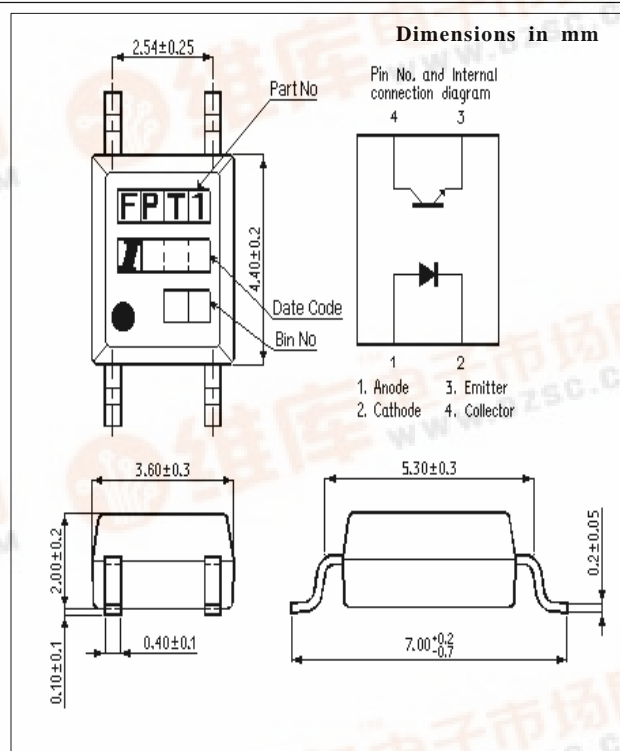

ISOCOM COMPONENTS LTD

Unit 25B, Park View Road West,
Park View Industrial Estate, Brenda Road
Hartlepool, Cleveland, TS25 1YD
Tel: (01429) 863609 Fax : (01429) 863581

ISOCOM INC

1024 S. Greenville Ave, Suite 240,
Allen, TX 75002 USA
Tel: (214)495-0755 Fax: (214)495-0901
e-mail info@isocom.com
http://www.isocom.com

ABSOLUTE MAXIMUM RATINGS
(25°C unless otherwise specified)

Storage Temperature	-40°C to +125°C
Operating Temperature	-30°C to +100°C
Lead Soldering Temperature (1/16 inch (1.6mm) from case for 10 secs)	260°C

INPUT DIODE

Forward Current	50mA
Reverse Voltage	6V
Power Dissipation	70mW

OUTPUT TRANSISTOR

Collector-emitter Voltage BV_{CEO}	35V
Emitter-collector Voltage BV_{ECO}	6V
Power Dissipation	150mW

POWER DISSIPATION

Total Power Dissipation	170mW
(derate linearly 2.26mW/°C above 25°C)	

ELECTRICAL CHARACTERISTICS ($T_A = 25^\circ\text{C}$ Unless otherwise noted)

PARAMETER		MIN	TYP	MAX	UNITS	TEST CONDITION
Input	Forward Voltage (V_F)		1.2	1.4	V	$I_F = 20\text{mA}$ $I_R = 10\mu\text{A}$ $V_R = 4\text{V}$
	Reverse Voltage (V_R)	5			V	
	Reverse Current (I_R)			10	μA	
Output	Collector-emitter Breakdown (BV_{CEO})	35			V	$I_C = 0.5\text{mA}$
	Emitter-collector Breakdown (BV_{ECO})	6			V	$I_E = 0.1\text{mA}$
	Collector-emitter Dark Current (I_{CEO})			100	nA	$V_{CE} = 20\text{V}$
Coupled	Current Transfer Ratio (CTR)	50		600	%	$5\text{mA } I_F, 5\text{V } V_{CE}$
	Optional CTR Grades:					
	IS2701-1A	80		160	%	$5\text{mA } I_F, 5\text{V } V_{CE}$
	IS2701-1B	130		260	%	$5\text{mA } I_F, 5\text{V } V_{CE}$
	IS2701-1C	200		400	%	$5\text{mA } I_F, 5\text{V } V_{CE}$
	IS2701-1D	300		600	%	$5\text{mA } I_F, 5\text{V } V_{CE}$
	Collector-emitter Saturation Voltage $V_{CE(SAT)}$			0.2	V	$20\text{mA } I_F, 1.0\text{mA } I_C$
Input to Output Isolation Voltage V_{ISO}	3750 5300			V_{RMS} V_{PK}	See note 1 See note 1	
Input-output Isolation Resistance R_{ISO}	5×10^{10}			Ω	$V_{IO} = 500\text{V}$ (note 1)	
Output Rise Time tr		4	18	μs	$V_{CE} = 2\text{V}$,	
Output Fall Time tf		3	18	μs	$I_C = 2\text{mA}, R_L = 100\Omega$	

Note 1 Measured with input leads shorted together and output leads shorted together.

TAPING DIMENSIONS

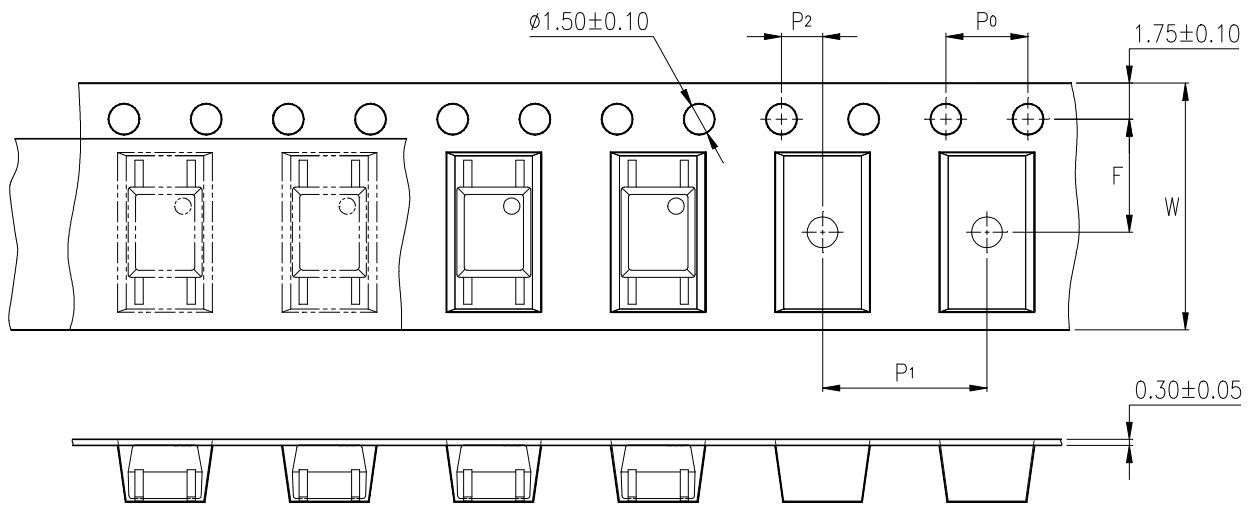

Description	Symbol	Dimensions in mm (inches)
Tape wide	W	12 ± 0.3 (.47)
Pitch of sprocket holes	P_0	4 ± 0.1 (.15)
Distance of compartment	F	5.5 ± 0.1 (.217)
	P_2	2 ± 0.1 (.079)
Distance of compartment to compartment	P_1	8 ± 0.1 (.315)

CHARACTERISTIC CURVES

Fig.1 Forward Current vs. Ambient Temperature

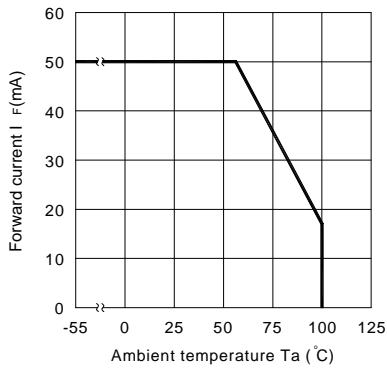

Fig.2 Collector Power Dissipation vs. Ambient Temperature

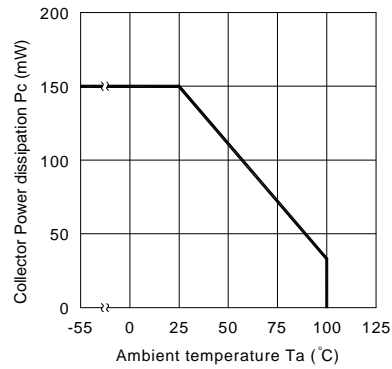

Fig.3 Collector-emitter Saturation Voltage vs. Forward Current

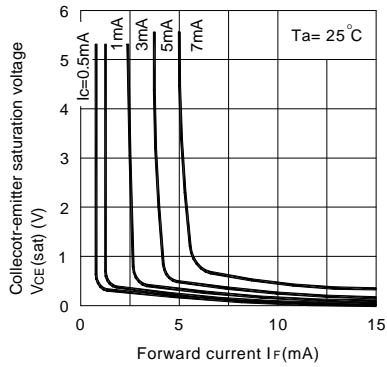

Fig.4 Forward Current vs. Forward Voltage

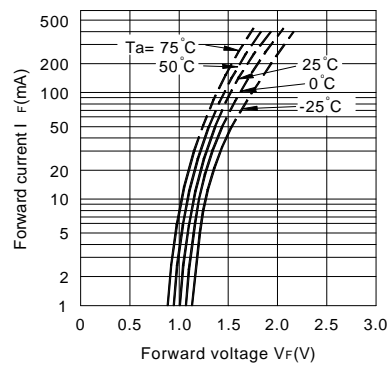

Fig.5 Current Transfer Ratio vs. Forward Current

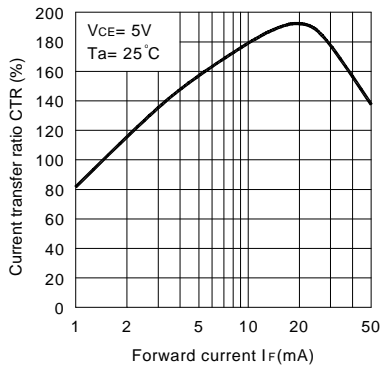
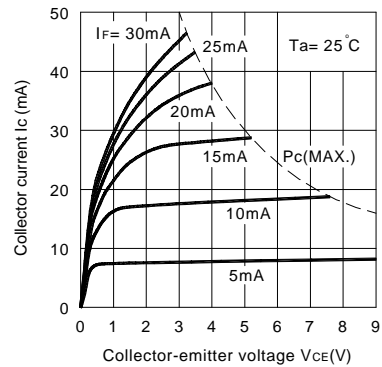

Fig.6 Collector Current vs. Collector-emitter Voltage



CHARACTERISTIC CURVES

Fig.7 Relative Current Transfer Ratio vs. Ambient Temperature

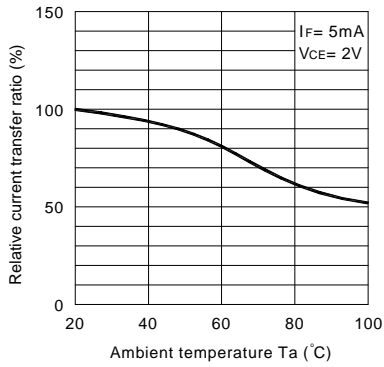

Fig.8 Collector-emitter Saturation Voltage vs. Ambient Temperature

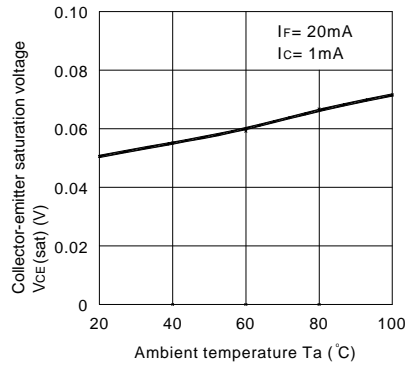

Fig.9 Collector Dark Current vs. Ambient Temperature

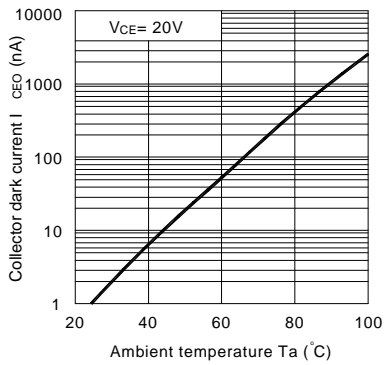

Fig.10 Response Time vs. Load Resistance

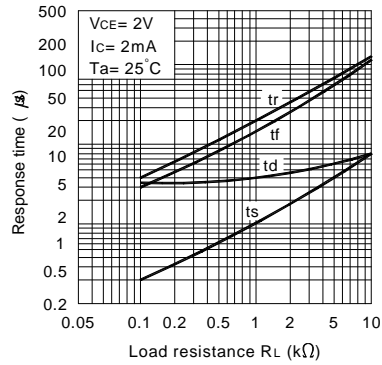
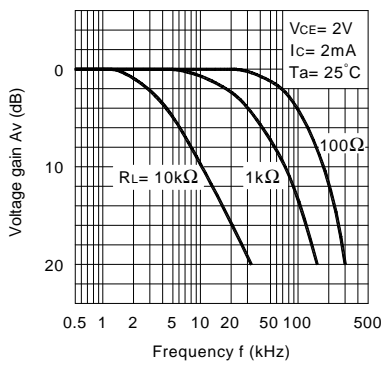
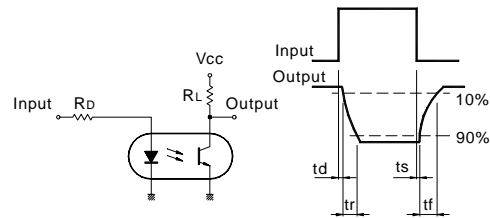

Fig.11 Frequency Response



Test Circuit for Response Time



Test Circuit for Frequency Response

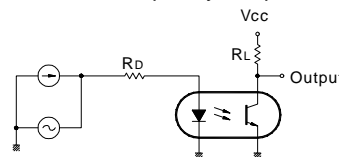

TEMPERATURE PROFILE OF SOLDERING REFLOW

- (1) One time soldering reflow is recommended within the condition of temperature and time profile shown below.

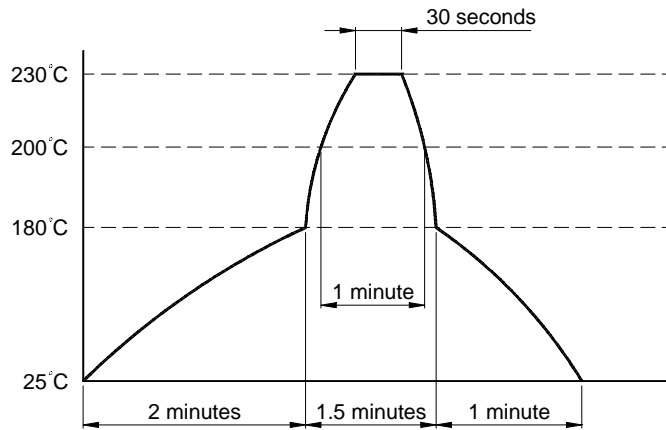

- (2) When using another soldering method such as infrared ray lamp, the temperature may rise partially in the mold of the device.
Keep the temperature on the package of the device within the condition of above (1).