



QUAD 2:1 MULTIPLEXER

SY10E157
SY100E157

FEATURES

- Individual select controls
- Extended 100E VEE range of $-4.2V$ to $-5.5V$
- 550ps max. D to Output
- 800ps max. SEL to Output
- Internal $75K\Omega$ input pull-down resistors
- Fully compatible with industry standard 10KH, 100K ECL levels
- Available in 28-pin PLCC package

DESCRIPTION

The SY10/100E157 contain four 2:1 multiplexers with differential outputs. The output data are controlled by the individual Select (SEL) inputs. The individual select control makes the devices well suited for random logic designs.

BLOCK DIAGRAM

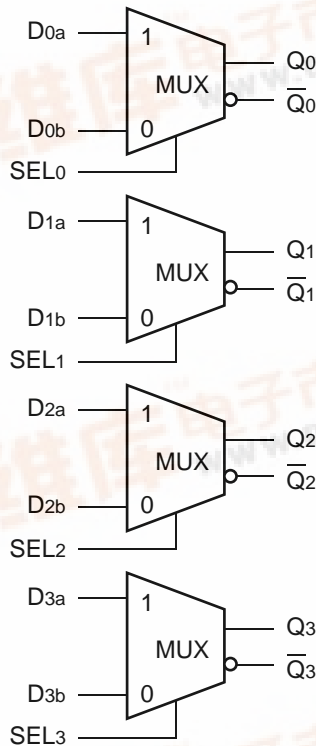

PIN CONFIGURATION

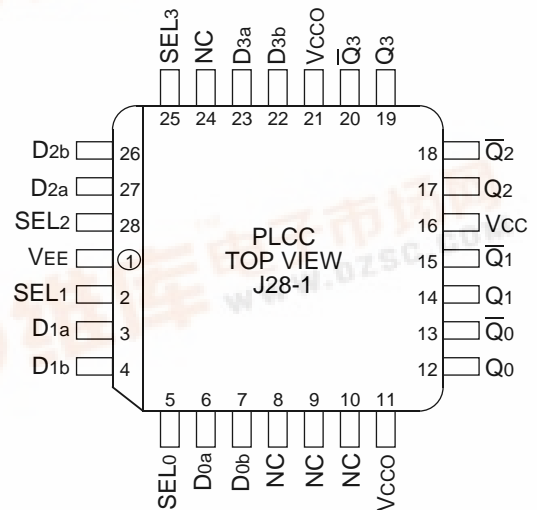

PIN NAMES

Pin	Function
D0a – D3a	Input Data a
D0b – D3b	Input Data b
SEL0 – SEL3	Select Inputs
Q0 – Q3	True Outputs
Q0-bar – Q3-bar	Inverted Outputs
VCCO	Vcc to Output



TRUTH TABLE

SEL	Data
H	a
L	b

DC ELECTRICAL CHARACTERISTICSV_{EE} = V_{EE} (Min.) to V_{EE} (Max.); V_{CC} = V_{CCO} = GND

Symbol	Parameter	T _A = -40°C			T _A = 0°C			T _A = +25°C			T _A = +85°C			Unit
		Min.	Typ.	Max.	Min.	Typ.	Max.	Min.	Typ.	Max.	Min.	Typ.	Max.	
I _{IH}	Input HIGH Current	—	—	200	—	—	200	—	—	200	—	—	200	μA
	D SEL	—	—	150	—	—	150	—	—	150	—	—	150	
I _{EE}	Power Supply Current	—	—	—	—	—	—	—	—	—	—	—	—	mA
	10E	—	32	38	—	32	38	—	32	38	—	32	38	
	100E	—	32	38	—	32	38	—	32	38	—	37	44	

AC ELECTRICAL CHARACTERISTICSV_{EE} = V_{EE} (Min.) to V_{EE} (Max.); V_{CC} = V_{CCO} = GND

Symbol	Parameter	T _A = -40°C			T _A = 0°C			T _A = +25°C			T _A = +85°C			Unit
		Min.	Typ.	Max.	Min.	Typ.	Max.	Min.	Typ.	Max.	Min.	Typ.	Max.	
t _{PLH} t _{PHL}	Propagation Delay to D SEL	220 425	380 600	550 800	220 425	380 600	550 800	220 425	380 600	550 800	220 425	380 600	550 800	ps
t _{skew}	Within-Device Skew ⁽¹⁾	—	70	—	—	70	—	—	70	—	—	70	—	
t _r t _f	Rise/Fall Time 20% to 80%	275	400	650	275	400	650	275	400	650	275	400	650	ps

NOTE:

1. Within-device skew is defined as identical transitions on similar paths through a device.

PRODUCT ORDERING CODE

Ordering Code	Package Type	Operating Range
SY10E157JC	J28-1	Commercial
SY10E157JCTR	J28-1	Commercial
SY100E157JC	J28-1	Commercial
SY100E157JCTR	J28-1	Commercial

Ordering Code	Package Type	Operating Range
SY10E157JI	J28-1	Industrial
SY10E157JITR	J28-1	Industrial
SY100E157JI	J28-1	Industrial
SY100E157JITR	J28-1	Industrial

28 LEAD PLCC (J28-1)

