

QUARTZ CRYSTAL OSCILLATOR

4

■ GENERAL DESCRIPTION

The NJU6361A is a C-MOS quartz crystal oscillator which consists of an oscillation amplifier, 3-stage divider, output frequency selector and inverter output buffer.

The oscillation frequency is as wide as up to 50MHz and the symmetry of 45-55% is realized over full oscillation frequency range.

The oscillation amplifier incorporates feed-back resistance and oscillation capacitors(Cg, Cd), therefore, it requires no external component except quartz crystal.

The 3-stage divider outputs  $f_0$ ,  $f_0/2$ ,  $f_0/4$  and  $f_0/8$  to the output frequency selector and it determined one output frequency according to the combination of two input-signal.

The inverter output buffer is C-MOS compatible and capable of 10 LSTTL driving.

■ PACKAGE OUTLINE



NJU6361AC



NJU6361AE

■ PIN CONFIGURATION/PAD LOCATION

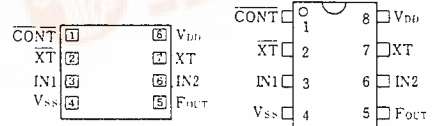

■ FEATURES

- Operating Voltage -- 3.0~6.0V
- Maximum Oscillation Frequency -- 50MHz
- Low Operating Current
- High Fan-out -- LSTTL 10
- Inverter Output Buffer
- Selected Frequency Output  
Only one frequency out of  $f_0$ ,  $f_0/2$ ,  $f_0/4$  and  $f_0/8$  output
- Oscillation Capacitors Cg and Cd on-chip
- Oscillation and Output Stand-by Function
- Package Outline -- CHIP/EMP 8
- C-MOS Technology

■ COORDINATES

Unit:  $\mu\text{m}$

| No. | PAD  | X    | Y   |
|-----|------|------|-----|
| 1   | CONT | 165  | 651 |
| 2   | XT   | 165  | 484 |
| 3   | IN1  | 165  | 317 |
| 4   | VSS  | 165  | 149 |
| 5   | FOUT | 1113 | 149 |
| 6   | IN2  | 1113 | 317 |
| 7   | XT   | 1113 | 484 |
| 8   | VDD  | 1113 | 651 |

Chip Size : 1.28 X 0.8mm  
Chip Thickness : 400  $\mu\text{m} \pm 30 \mu\text{m}$

■ BLOCK DIAGRAM

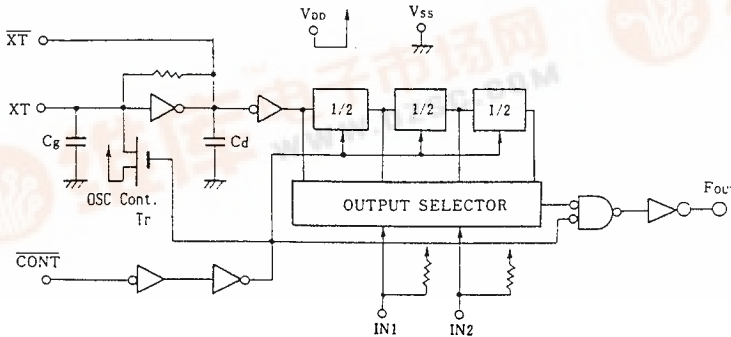

**■ TERMINAL DESCRIPTION**

| NO. | SYMBOL           | F U N C T I O N   |   |     |                   |
|-----|------------------|---|---|-----|-------------------|
| 1   | CONT             | Oscillation Stop Control and Divider Reset  |   |     |                   |
|     |                  | CONT  | F <sub>OUT</sub>  |     |                   |
|     |                  | H   | Output either one frequency from f <sub>0</sub> , f <sub>0</sub> /2, f <sub>0</sub> /4, and f <sub>0</sub> /8 |     |                   |
|     |                  | L   | Oscillation stop and Divider Reset  |     |                   |
| 2   | XT               | Quartz Crystal Connecting Terminals   |   |     |                   |
| 7   | XT               |   |   |     |                   |
| 8   | V <sub>DD</sub>  | + 5V  |   |     |                   |
| 3   | IN1              | 3-State Divider Outputs selected by IN1 and IN2   |   |     |                   |
|     |                  |   | IN1   | IN2 | F <sub>OUT</sub>  |
|     |                  |   | H   | H   | f <sub>0</sub>    |
|     |                  |   | L   | H   | f <sub>0</sub> /2 |
| 6   | IN2              |   | H   | L   | f <sub>0</sub> /4 |
|     |                  |   | L   | L   | f <sub>0</sub> /8 |
| 5   | F <sub>OUT</sub> | Output either one frequency from f <sub>0</sub> , f <sub>0</sub> /2, f <sub>0</sub> /4, and f <sub>0</sub> /8 |   |     |                   |
| 4   | V <sub>SS</sub>  | GND   |   |     |                   |

**■ ABSOLUTE MAXIMUM RATINGS**

 ( T<sub>a</sub>=25°C )

| PARAMETER                   | SYMBOL           | RATINGS                     | UNIT |
|-----------------------------|------------------|-----------------------------|------|
| Supply Voltage              | V <sub>DD</sub>  | -0.5 ~ +7.0                 | V    |
| Input Voltage               | V <sub>IN</sub>  | -0.5 ~ V <sub>DD</sub> +0.5 | V    |
| Output Voltage              | V <sub>O</sub>   | -0.5 ~ V <sub>DD</sub> +0.5 | V    |
| Input Current               | I <sub>IN</sub>  | ±10                         | mA   |
| Output Current              | I <sub>O</sub>   | ±25                         | mA   |
| Power Dissipation (EMP)     | P <sub>D</sub>   | 200                         | mW   |
| Operating Temperature Range | T <sub>opr</sub> | -40 ~ + 85                  | °C   |
| Storage Temperature Range   | T <sub>stg</sub> | -65 ~ +150                  | °C   |

**■ ELECTRICAL CHARACTERISTICS**

 ( T<sub>a</sub>=25°C, V<sub>DD</sub>=5V )

| PARAMETER               | SYMBOL                          | CONDITIONS  | MIN | TYP | MAX | UNIT |
|-------------------------|---------------------------------|---|-----|-----|-----|------|
| Operating Voltage       | V <sub>DD</sub>                 |   | 3   |     | 6   | V    |
| Operating Current       | I <sub>DD</sub>                 | f <sub>osc</sub> =16MHz, No load                                |     |     | 10  | mA   |
| Stand-by Current        | I <sub>st</sub>                 | CONT, XT=V <sub>SS</sub> , No load (Note)                       |     |     | 1   | μA   |
| Input Voltage           | V <sub>IH</sub>                 |   | 3.5 |     | 5.0 | V    |
|                         | V <sub>IL</sub>                 |   | 0   |     | 1.5 | V    |
| Output Current          | I <sub>OH</sub>                 | V <sub>DD</sub> =5V, V <sub>OH</sub> =4.5V                      | 4   |     |     | mA   |
|                         | I <sub>OL</sub>                 | V <sub>DD</sub> =5V, V <sub>OL</sub> =0.5V                      | 4   |     |     | mA   |
| Input Current           | I <sub>IN</sub>                 | CONT, IN1, IN2 Terminals<br>CONT, IN1, IN2=V <sub>SS</sub>      |     |     | 400 | μA   |
| Internal Capacitor      | C <sub>g</sub>                  | A Version   |     | 21  |     | pF   |
|                         | C <sub>d</sub>                  | A Version   |     | 23  |     | pF   |
|                         | C <sub>g</sub> , C <sub>d</sub> | P Version   |     | -   |     | pF   |
| Max. Oscillation Freq.  | f <sub>MAX</sub>                | V <sub>DD</sub> =5V, C <sub>L</sub> =15pF                       | 50  |     |     | MHz  |
| Output Signal Symmetry  | SYM                             | V <sub>DD</sub> =5V, C <sub>L</sub> =15pF at 1/2V <sub>DD</sub> | 45  | 50  | 55  | %    |
| Output Signal Rise Time | t <sub>r</sub>                  | V <sub>DD</sub> =5V, C <sub>L</sub> =15pF, 10% - 90%            |     |     | 8   | ns   |
| Output Signal Fall Time | t <sub>f</sub>                  | V <sub>DD</sub> =5V, C <sub>L</sub> =15pF, 90% - 10%            |     |     | 8   | ns   |

Note ) Excluding input current on CONT terminal.

■ MEASUREMENT CIRCUITS

(1) Output Signal Symmetry ( $C_L=15\text{pF}$ )

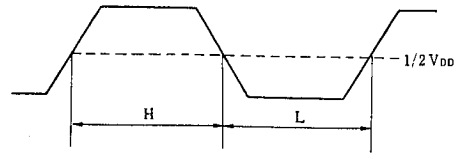
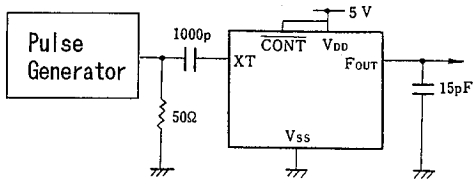

(2) Output Signal Rise/Fall Time ( $C_L=15\text{pF}$ )

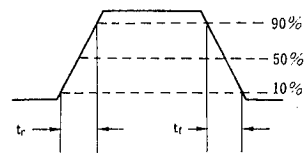
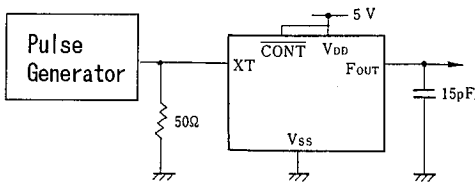

# NJU6361A

---

## MEMO

[CAUTION]  
The specifications on this databook are only given for information, without any guarantee as regards either mistakes or omissions. The application circuits in this databook are described only to show representative usages of the product and not intended for the guarantee or permission of any right including the industrial rights.