

Monolithic Linear IC

SANYO

No.4265A

LA7672**Color TV Single-Chip Signal Processor
for NTSC Systems (PLL Detection)****Overview**

The LA7672 is a single-chip IC for color TVs based on the NTSC system with on-chip circuit for all VIF, SIF, video, chroma and deflection signal processing.

Features**[VIF]**

- PLL detection (high video and audio quality)
- High-gain VIF amplifier
- High speed AGC
- On-chip APC time constant switch

[SIF]

- Simultaneous sound IN/OUT
- Video/audio simultaneous muting, or audio-only muting possible

[Audio-visual switch]

- Internal/external audio-visual switch ($V_{CC} = 9V$)

Delay line	Video external, audio external	Switch rating
OFF	IN	6.9 to 9.0V
OFF	EXT	4.7 to 6.6V
ON	EXT	2.4 to 4.3V
ON	IN	0 to 2.1V

[OSD]

- RGB 3 input
- RGB linear up ($-6dB$ input : 2 to 5V)
- Fast blanking (B input combined use)

[Chroma]

- On-chip ACC filter, On-chip killer filter, Killer-circuit hysteresis operation
- On-chip carrier filter

[Video]

- Black enhancement
- On-chip delay line
- Wide band width (9MHz): delay line short
- Dual rank on-chip differentiation circuit also available for soft also
- S input supported (VCR application)
- Variable DC transmission volume available (externally attached circuit adjustment)

[Deflection]

- Adjustment-free horizontal, vertical synchronization
- Dual AFC system with excellent anti-noise characteristics
- External adjustment of vertical synchronization sensitivity
- Vertical size is constant with no-signal
- Highly stable image during playback of copy protected tapes (macro-vision tape)
- High stability against VCR skew distortion

Package Dimensions

(unit : mm)

3128

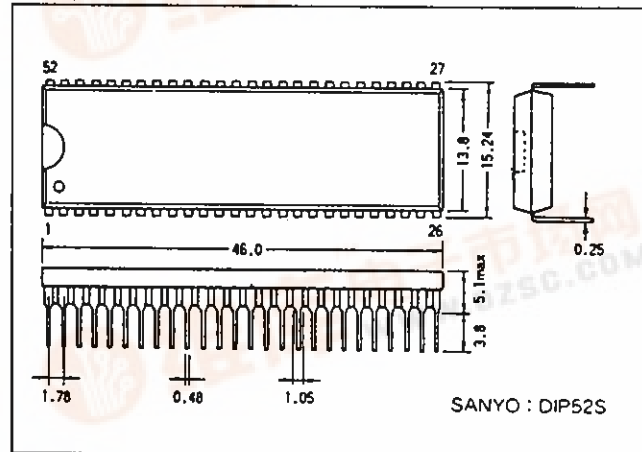

LA7672

Maximum Ratings at Ta = 25° C

			unit
Maximum Supply Voltage	V11 max	11	V
	V14 max	11	V
Maximum Supply Current	I30max	16	mA
Allowable Power dissipation	Pd max	Ta ≤ 60°C	1.35 W
Operating Temperature Range	Topr	-10 to +65	°C
Storage Temperature Range	Tstg	-55 to +150	°C
Circuit Current	I44	-6	mA
	I6	-3	mA
FBP Input Current	I22 max	Peak current	5 mA
	I21 max	Peak current	10 mA

Operating Conditions at Ta = 25° C

			unit
Recommended Supply Voltage	V11	9	V
	V14	9	V
Recommended Supply Current	I30	13	mA
Operating Voltage Range	V11op	8 to 9.5	V
	V14op	8 to 9.5	V
Operating Current Range	I30op	10 to 16	mA

Operating Characteristics at Ta = 25°C, VCC = V11 = V14 = 9 V, ICC = I30 = 13 mA

[Circuit Voltage and Current]

			min	typ	max	unit
Horizontal Supply Voltage	V30	VCC = 9V, ICC = 13mA	7.3	7.8	8.3	V
Supply Current	I11 + 14	VCC = 9V, ICC = 13mA, IF AGC 4V	102	120	138	mA

[VIF]

Quiescent Video Output Voltage	V44	Quiescent	4.3	4.7	5.1	V
Quiescent AFT Output Voltage	V47	Quiescent	3.1	4.7	6.1	V
Maximum RFAGC Voltage	V49H	CW = 85dBμ, RFAGCVR = min	7.6	8.0	8.3	V
Minimum RFAGC Voltage	V49L	CW = 85dBμ, RFAGCVR = max	0	0.01	0.3	V
Input Sensitivity	Vi	VIF input level for video output at 0.8Vp-p (40% mod).	33	39	45	dBμ
AGC Range	GR	Maximum input (V0 = 0.8Vp-p) - input sensitivity	54	62		dB
Maximum Permissible Input	Vi max	VIF input level for video output at +1dB	97	104		dBμ
Video Output Detection	VO44	Vi = 80dBμ, AM = 78% mod	1.7	2.0	2.3	Vp-p
Differential Gain	DG	Vi = 80dBμ, AM = 87.5%, video mod		3.0	10	%
Differential Phase	DP	Vi = 80dBμ, AM = 87.5%, video mod		1.0	10	deg
Video S/N	S/N	Vi = 80dBμ, 20 log $\frac{1.46 (Vp-p)}{\text{noise } (V_{rms})}$	47	54		dB
Synchronization Signal Tip Level	V44 TIP	CW = 80dBμ	2.1	2.4	2.7	V
Frequency Characteristic	fC	Frequency at video output of -3dB	6.0	9.0		MHz
920 kHz VIF Intermodulation	I920	V3.58MHz/V920kHz, Vi = 80dBμ	35	42		dB
Maximum AFT Output Voltage	V47H	CW = 80dBμ, frequency change	8.3	8.7	9.0	V
Minimum AFT Output Voltage	V47L	CW = 80dBμ, frequency change	0.1	0.3	0.8	V
AFT Detection Sensitivity	Sf	CW = 80dBμ, frequency change	45	70	100	mV/kHz
AFT Switch Operation Start Voltage	VAFTSW	Measuring with sweep signal	0.5	1.0		V
Black Noise Threshold Level	VBTH	Measuring with sweep signal	1.1	1.4	1.7	V
APC Pull-in Range (U)2	fPU-2	CW = 80dBμ, fp = 53MHz to 64MHz	0.8	1.7		MHz
APC Pull-in Range (L)2	fPL-2	CW = 80dBμ, fp = 53MHz to 64MHz		-2	-1	MHz
VCO Maximum Variable Range	ΔfU	Quiescent	0.9	1.7		MHz
	ΔfL	Quiescent		-2	-1	MHz
VCO Control Sensitivity	β	Quiescent	1.5	3.0	5.5	kHz/mV

[Audio-visual Switches]

Video Output DC Voltage	V38	Quiescent	3.0	3.4	3.8	V
Internal Video Input Voltage	V42	Quiescent	4.4	4.8	5.2	V
External Video Input Voltage	V40	Quiescent	4.4	4.8	5.2	V
External Audio Input Voltage	V3	Quiescent	5.2	5.6	6.0	V

Continued on next page.

LA7672

Continued from preceding page.			min	typ	max	unit
[SIF AF]						
SIF Limiting Voltage	$V_{i\ lim}$	SIF output level for detection output at -3dB		40	47	dB μ
FM Detection Output Voltage	V_{O1}	$V_i = 100\text{dB}\mu, \Delta f = \pm 25\text{kHz}$	380	550	750	mVrms
FM Detection Output Distortion Ratio	THD	$V_i = 100\text{dB}\mu, \Delta f = \pm 25\text{kHz}$		0.4	1.0	%
AM Rejection	AMR	$V_i = 100\text{dB}\mu, \frac{FM : \Delta f = \pm 25\text{kHz}}{AM : 30\%}$	40	60		dB
AF Amplifier Voltage Gain	G_{AF}	$V_i = 100\text{mVrms}, f = 400\text{Hz}$	18	20	22	dB
AF Maximum Output Voltage	$V_{O6\ max}$	Output level for AF amplifier output distortion at 10%	2.0	2.8		Vrms
AF Electronic Attenuator Range	ATT	$V_i = 200\text{mVrms}, f = 400\text{Hz}$	70	80		dB
[Video]						
Black Enhancement Threshold	B_{STH}	APL variable	40	50	60	IRE
Maximum Black Enhancement Gain	$BS\ max$	APL variable	-35	-27	-20	IRE
Soft Video Tone Variable Range	ΔSoft	$f = 2\text{MHz}, 100\text{mVp-p}$ video tone VR: 4V \rightarrow 0V	-6	-4	-2	dB
Sharp Video Tone Variable Range	ΔSharp	$f = 2\text{MHz}, 100\text{mVp-p}$ video tone VR: 4V \rightarrow 9V, contrast VR: 6V	7	10	13	dB
Video Voltage Gain Audio-visual Switch 9V	GV9V	$f = 100\text{kHz}, 100\text{mVp-p}, \text{contrast VR: } 9\text{V}, \text{video tone VR: } 4\text{V}$	15	18	21	dB
Video Voltage Gain Audio-visual Switch 0V	GV0V	$f = 100\text{kHz}, 100\text{mVp-p}, \text{contrast VR: } 0\text{V}, \text{video tone VR: } 4\text{V}$	15	18	21	dB
Contrast Control Center	C_{CEN}	$f = 100\text{kHz}, 100\text{mVp-p}, \text{contrast VR: } 6\text{V}$	0.4	0.48	0.57	Vp-p
Contrast Variable Control Range	ΔC_V	Contrast VR: 3V \rightarrow 9V	18	20	22	dB
Bright Control	$B\ R_H$	Bright VR: 1.5V	5.5	6.5	7.5	V
	$B\ R_{CEN}$	Bright VR: 4.5V	2.3	2.8	3.3	V
	$B\ R_L$	Bright VR: 7V		0.3	1.2	V
DL Off Frequency Characteristics	$f_V\ 9V$	Contrast VR: 6V, video tone VR: 4V, 3dB down	7	9		MHz
DL On Frequency Characteristics	$f_V\ 0V$	Contrast VR: 6V, video tone VR: 4V, 3dB down	2.5	3		MHz
DC Transmission	R_{DC}	Input: stair step signal, 500mVp-p	100	103	106	%
Delay Line Delay	T_{DL}	Input: white 100%	290	340	390	ns
[Chroma]						
ACC Amplitude Characteristics	A_{CC1}	+6dB	-3	0	+3	dB
	A_{CC2}	-20dB	-7		+2	dB
ACC Phase Characteristics	A_{CCP1}	+6dB	-3	0	+3	deg
	A_{CCP2}	-20dB	-7		+7	deg
Killer Operation Point	E_K		-35	-28	-21	dB
Color Control Color Residual	$E_C\ min$	Color VR: 0V, contrast VR: 9V			30	mVp-p
Color Control Center	$E_C\ CEN$	Color VR: 4.5V, contrast VR: 6V	1.2	1.8	2.4	Vp-p
Maximum Demodulation Output	$E_C\ max$	Color VR: 9V, contrast VR: 9V	3.2	4.0		Vp-p
Color Contrast Variable Range	ΔC_C	Color VR: B - Y = 2.5Vp-p, contrast VR: 3V \rightarrow 9V	17.5	19.5	21.5	dB
Tint Control Center	T_{CEN}	Tint VR: 4.5V, color VR: 4.5V, contrast VR: 6V	0	12	24	deg
Tint Variable Range	ΔT	Tint VR: 0V \leftarrow 4.5V \rightarrow 8V, color VR: 4.5V, contrast VR: 6V	± 40			deg
APC Pull-in Range	Δf_{APC}		± 300			Hz
Demodulator Output Ratio	R/B	Monochrome signal, contrast VR: 6V, color VR: B - Y = 1Vpo	0.81	0.90	0.98	
	G/B	Monochrome signal, contrast VR: 6V, color VR: B - Y = 1Vpo	0.24	0.30	0.38	
Demodulator Phase Angle	RB	Monochrome signal, contrast VR: 6V, color VR: B - Y = 1Vpo	97	105	113	deg
	GB	Monochrome signal, contrast VR: 6V, color VR: B - Y = 1Vpo	-130	-120	-110	deg
Demodulator Output DC Voltage	V_{C-Y}	Burst signal only, color VR: 0V	4.7	5.2	5.7	V
Demodulator Output DC Offset Voltage	ΔV_{C-Y}	Burst signal only, color VR: 0V	-200	0	+200	mV
Demodulator Output Residual Carrier	E car	Quiescent, killer off, color VR: 0V			0.03	Vp-p

Continued on next page.

LA7672

Continued from preceding page.		min	typ	max	unit
[OSD]					
Blanking Pulse Threshold Level	TH _{BL} C - IN: color bar, B - IN: variable	0.5	0.8	1.1	V
- Y Out DC Voltage (OSD mode)	V _{-Y} B-IN : 1.5V	2.5	2.8	3.1	V
RGB - In Threshold Level	TH _R R - IN: variable, B - IN: 1.5V	1.9	2.2	2.5	V
	TH _G G - IN: variable, B - IN: 1.5V				
	TH _B B - IN, variable				
RGB - Y Out DC Voltage (3 V)	V _{R3V} R, G, B - IN :3V	5.2	5.5	5.8	V
	V _{G3V}				
	V _{B3V}				
RGB - Y Out DC Voltage (4 V)	V _{R4V} R, G, B - IN : 4V	5.7	6.0	6.3	V
	V _{G4V}				
	V _{B4V}				
RGB - Y Out DC Voltage (5 V)	V _{R5V} R, G, B - IN : 5V	6.2	6.5	6.8	V
	V _{G5V}				
	V _{B5V}				
[Deflection]					
Synchronization Separator Input DC Level	V _{SDC}	6.0	6.3	6.6	V
Vertical Free-Running Period	T _{V free}	262	262.5	263	H
Maximum Vertical Synchronization Period	T _{V max} Input: horizontal synchronization signal only	296.5	297	297.5	H
Minimum Vertical Synchronization Period	T _{V min}	224.5	225	225.5	H
Vertical Blanking Pulse Width	P _{W VBL}	20.25	20.5	20.75	H
Vertical Blanking Pulse Wave Height Value	P _{H VBL}	7.0	7.5		V
Vertical Output Pulse Width	P _{W VOUT}	8.25	8.5	8.75	H
Vertical Output Voltage	V _{OUT H}	5.7	6	6.3	V
	V _{OUT M}	4.2	4.5	4.8	V
	V _{OUT L}			0.3	V
Vertical External Trigger Load Resistance	R _{TR}	2.7	3.6		kΩ
Vertical Automatic Synchronization Stop Voltage	V _{SAS}		1.9	2.4	V
Vertical Output Pulse Start V _{CC} Voltage	S _{VV}			4	V
Horizontal Free-Running Frequency Deviation	Δf _H Deviation from 15.734kHz	-90	30	150	Hz
Dependence of Horizontal Free-Running Frequency on V _{CC}	Δf _{H VCC} V30 = 6.7V, reference value		2		Hz
Horizontal Pull-in Range	f _{H PULL} Deviation from 15.734kHz	±400			Hz
Horizontal Output Pulse Width	P _{WH OUT}	21.8	23.8	25.8	μs
Horizontal Output Pulse Phase	H _{PF}	12			μs
	H _{PCEN}	3.4	4.4	5.4	μs
	H _{PR}			0	μs
				4.5	5.3
Horizontal Output Pulse Start V _{CC} Voltage	S _{HV}		4.5	5.3	V
AFC II FBP Peak Voltage	F _{BPH}	4.1	4.6	5.1	V
Burst Gate Pulse Delay Time	T _{d BGP}	0.2	0.6	1.2	μs
Burst Gate Pulse Width	P _{W BGP}	2.7	3.7	4.7	μs
VCR SW Input Voltage	V _{CR}		1.3	2.0	V
X-ray Protector Circuit Operation Input Voltage	V _{HD}	0.64	0.74	0.84	V
Horizontal Synchronization Detection Threshold Level	H _{coin}	4.2	4.5	4.8	V

Application Circuit Example

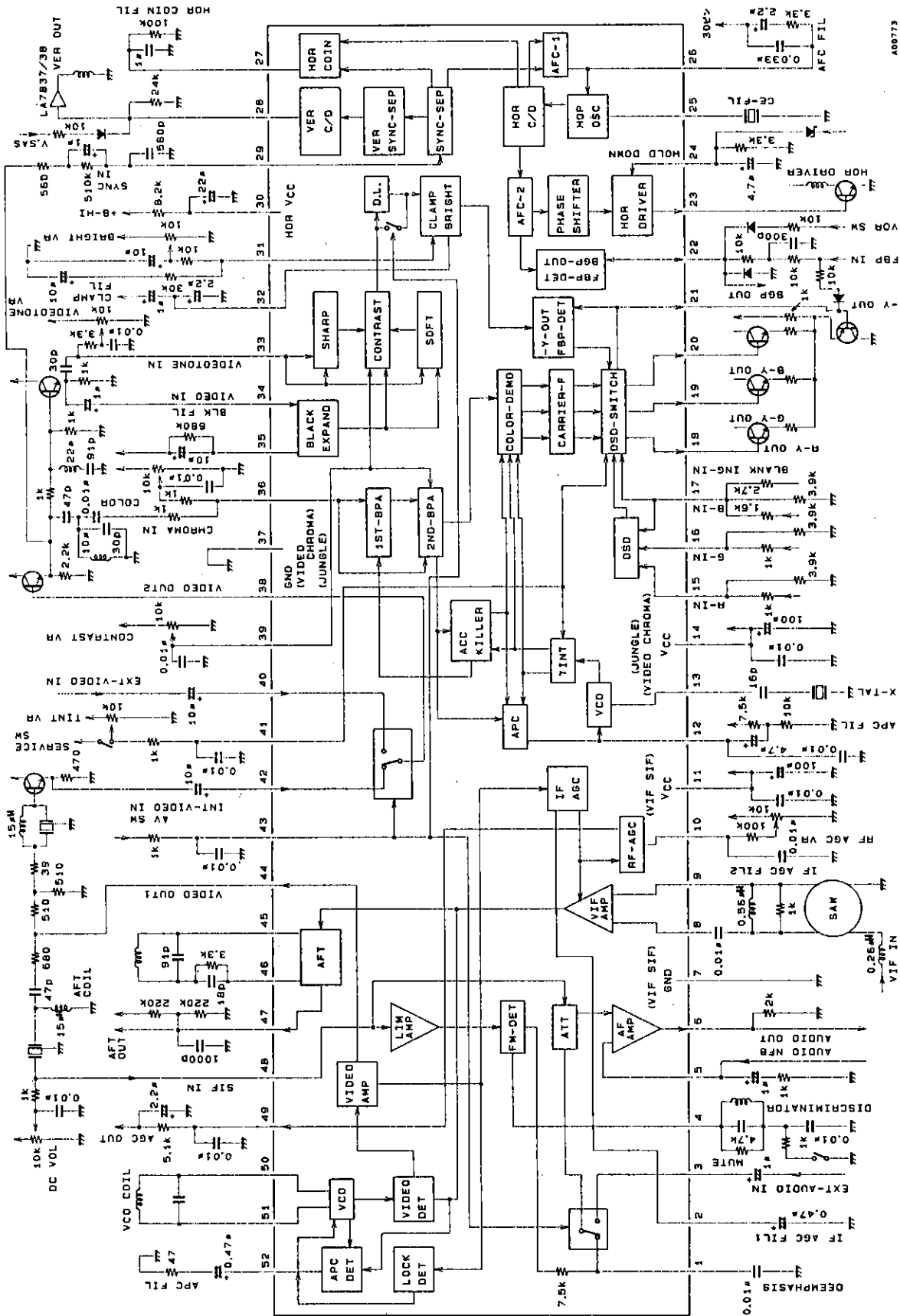

400773

Unit (resistance:Ω, capacitance:F)

- No products described or contained herein are intended for use in surgical implants, life-support systems, aerospace equipment, nuclear power control systems, vehicles, disaster/crime-prevention equipment and the like, the failure of which may directly or indirectly cause injury, death or property loss.
- Anyone purchasing any products described or contained herein for an above-mentioned use shall:
 - ① Accept full responsibility and indemnify and defend SANYO ELECTRIC CO., LTD., its affiliates, subsidiaries and distributors and all their officers and employees, jointly and severally, against any and all claims and litigation and all damages, cost and expenses associated with such use:
 - ② Not impose any responsibility for any fault or negligence which may be cited in any such claim or litigation on SANYO ELECTRIC CO., LTD., its affiliates, subsidiaries and distributors or any of their officers and employees jointly or severally.
- Information (including circuit diagrams and circuit parameters) herein is for example only; it is not guaranteed for volume production. SANYO believes information herein is accurate and reliable, but no guarantees are made or implied regarding its use or any infringements of intellectual property rights or other rights of third parties.

This catalog provides information as of **June, 1996**. Specifications and information herein are subject to change without notice.
