

DISCRETE SEMICONDUCTORS

DATA SHEET

LBE2003S; LBE2009S; LCE2009S NPN microwave power transistors

Product specification

1997 Mar 03

Supersedes data of November 1994

File under Discrete Semiconductors, SC15

NPN microwave power transistors

LBE2003S; LBE2009S; LCE2009S

FEATURES

- Diffused emitter ballasting resistors
- Self-aligned process entirely ion implanted and gold metallization
- Optimum temperature profile
- Excellent performance and reliability.

APPLICATIONS

- Common emitter class-A linear power amplifiers up to 4 GHz.

DESCRIPTION

The LBE2003S and LBE2009S are NPN silicon planar epitaxial microwave power transistors in a SOT441A metal ceramic studless package. The LCE2009S is a maintenance type in a SOT442A metal ceramic capstan package.

PINNING

PIN	DESCRIPTION
1	collector
2	emitter
3	base
4	emitter

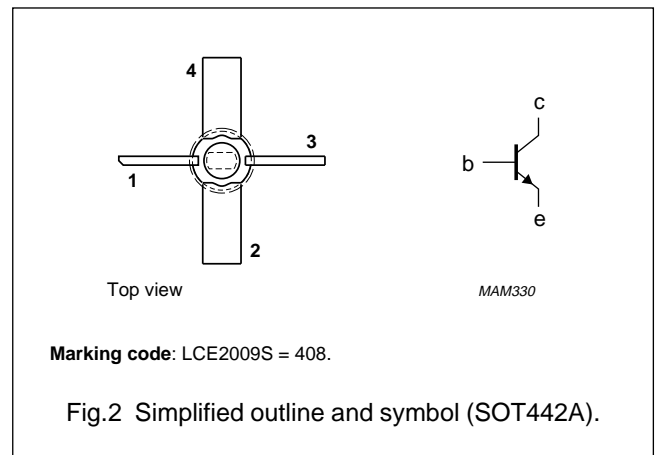
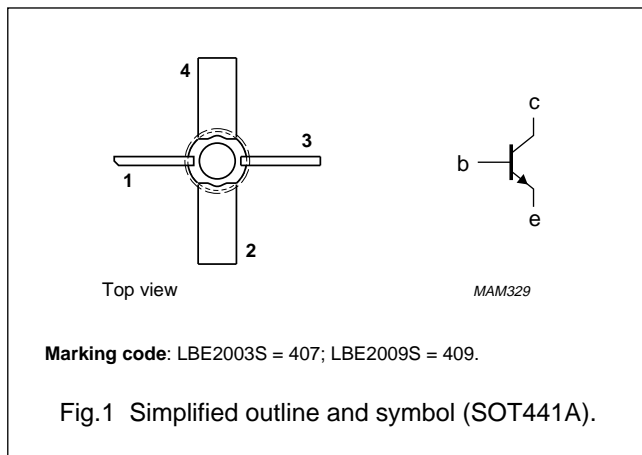

QUICK REFERENCE DATA

Microwave performance up to $T_{mb} = 25\text{ }^\circ\text{C}$ in a common emitter class-A amplifier.

TYPE NUMBER	MODE OF OPERATION	f (GHz)	V_{CE} (V)	I_C (mA)	P_{L1} (mW)	G_{po} (dB)	Z_i (Ω)	Z_L (Ω)
LBE2003S	Class-A (CW) linear	2	18	30	≥ 200	≥ 10	$6.2 + j30$	$17.5 + j7$
LBE2009S	Class-A (CW) linear	2	18	110	≥ 700	≥ 9	$7.5 + j15$	$17.5 + j39$
LCE2009S								

WARNING

Product and environmental safety - toxic materials

This product contains beryllium oxide. The product is entirely safe provided that the BeO disc is not damaged. All persons who handle, use or dispose of this product should be aware of its nature and of the necessary safety precautions. After use, dispose of as chemical or special waste according to the regulations applying at the location of the user. It must never be thrown out with the general or domestic waste.

LCE2009S IS A MAINTENANCE TYPE - NOT RECOMMENDED FOR NEW DESIGNS; SEE INDEX SECTION OF SC15

NPN microwave power transistors

LBE2003S; LBE2009S;
LCE2009S

LIMITING VALUES

In accordance with the Absolute Maximum Rating System (IEC 134).

SYMBOL	PARAMETER	CONDITIONS	MIN.	MAX.	UNIT
V _{CBO}	collector-base voltage	open emitter		40	V
V _{CER}	collector-emitter voltage				
	LBE2003S	R _{BE} = 220 Ω	–	35	V
	LBE2009S; LCE2009S	R _{BE} = 100 Ω	–	35	V
V _{CEO}	collector-emitter voltage	open base	–	16	V
V _{EBO}	emitter-base voltage	open collector	–	3	V
I _c	collector current (DC)				
	LBE2003S		–	90	mA
	LBE2009S; LCE2009S		–	250	mA
P _{tot}	total power dissipation	T _{mb} ≤ 75 °C			
	LBE2003S		–	1.4	W
	LBE2009S; LCE2009S		–	3.5	W
T _{stg}	storage temperature		–65	+150	°C
T _j	operating junction temperature		–	200	°C
T _{sld}	soldering temperature	at 0.3 mm from case; t = 10 s	–	235	°C

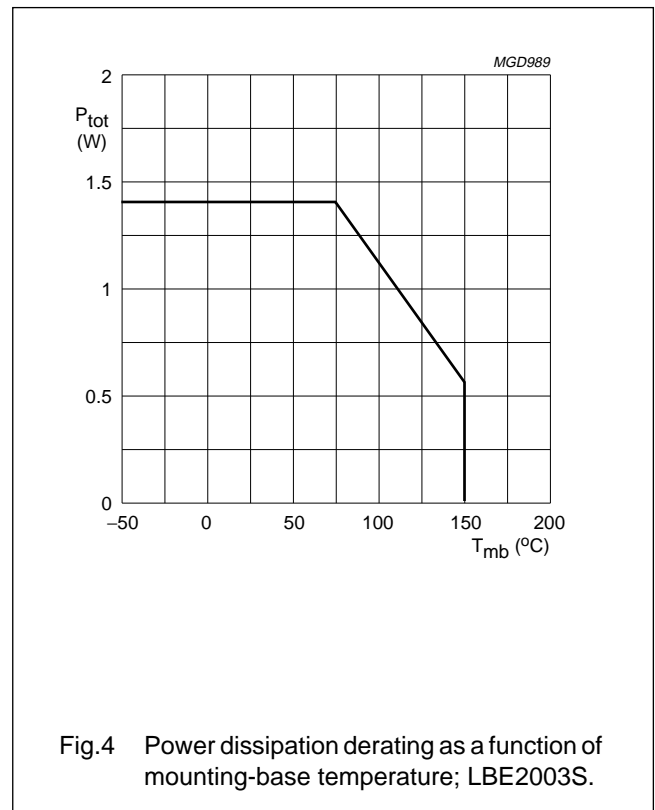
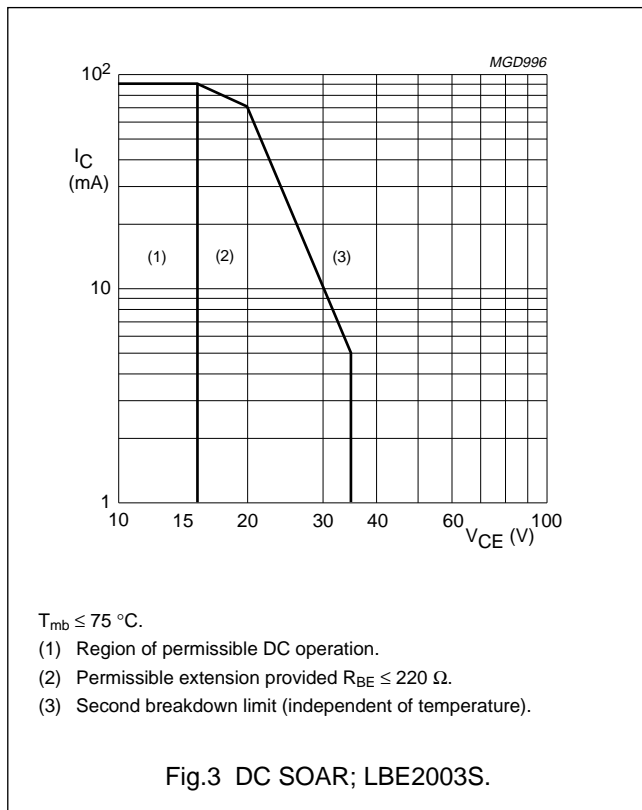

LCE2009S IS A MAINTENANCE TYPE - NOT RECOMMENDED FOR NEW DESIGNS; SEE INDEX SECTION OF SC15

NPN microwave power transistors

LBE2003S; LBE2009S;
LCE2009S

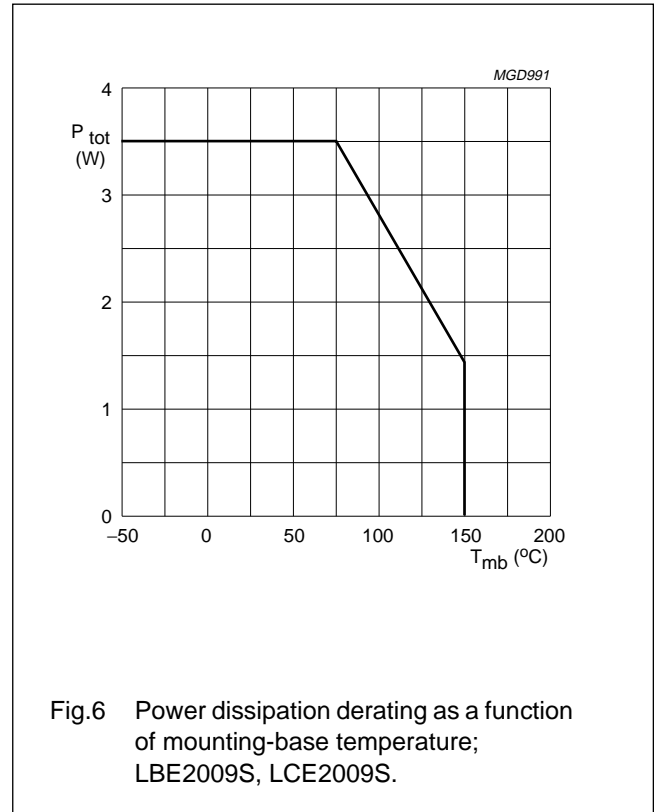
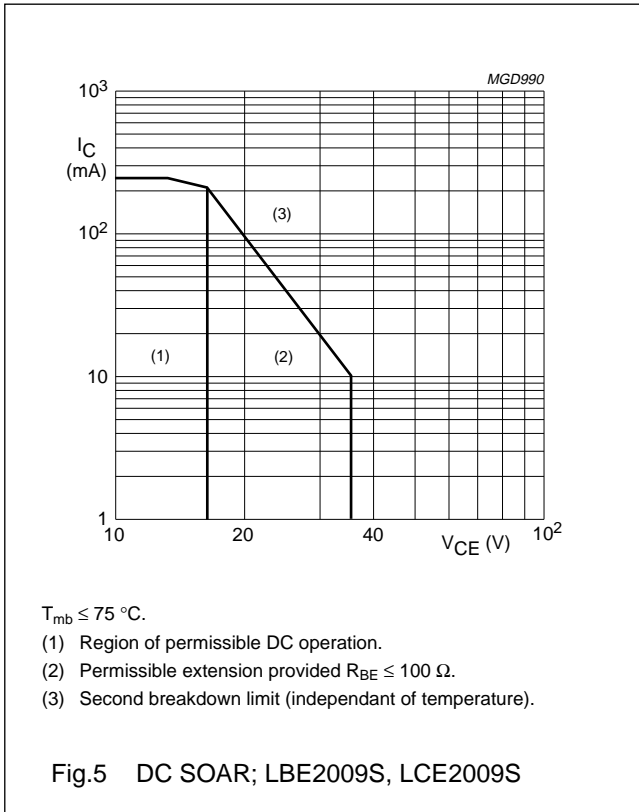

THERMAL CHARACTERISTICS

SYMBOL	PARAMETER	CONDITIONS	MAX.	UNIT
$R_{th\ j-mb}$	thermal resistance from junction to mounting-base	$T_j = 75^\circ\text{C}$; note 1	65	K/W
	LBE2003S LBE2009S; LCE2009S			
$R_{th\ mb-h}$	thermal resistance from mounting-base to heatsink	$T_j = 75^\circ\text{C}$; note 1	1.5	K/W

Note

- See "Mounting recommendations in the General part of handbook SC15".

LCE2009S IS A MAINTENANCE TYPE - NOT RECOMMENDED FOR NEW DESIGNS; SEE INDEX SECTION OF SC15

NPN microwave power transistors

LBE2003S; LBE2009S;
LCE2009S

CHARACTERISTICS

 $T_{mb} = 25\text{ }^{\circ}\text{C}$ unless otherwise specified.

SYMBOL	PARAMETER	CONDITIONS	MIN.	TYP.	MAX.	UNIT
I_{CBO}	collector cut-off current	$V_{CB} = 20\text{ V}; I_E = 0$	–	–	0.1	μA
I_{CBO}	collector cut-off current	$V_{CB} = 40\text{ V}; I_E = 0$				
	LBE2003S		–	–	150	μA
	LBE2009S; LCE2009S		–	–	250	μA
I_{CER}	collector cut-off current					
	LBE2003S	$V_{CB} = 35\text{ V}; R_{BE} = 220\ \Omega$	–	–	500	μA
	LBE2009S; LCE2009S	$V_{CB} = 35\text{ V}; R_{BE} = 100\ \Omega$	–	–	1000	μA
I_{EBO}	emitter cut-off current	$V_{EB} = 1.5\text{ V}; I_C = 0$				
	LBE2003S		–	–	0.05	μA
	LBE2009S; LCE2009S		–	–	0.2	μA
h_{FE}	DC current gain	$V_{CE} = 5\text{ V}; I_C = 30\text{ mA}$	15	–	150	
		$V_{CE} = 5\text{ V}; I_C = 110\text{ mA}$	15	–	150	
C_{cb}	collector-base capacitance	$V_{CB} = 18\text{ V}; V_{EB} = 1.5\text{ V};$ $I_E = I_C = 0; f = 1\text{ MHz}$				
	LBE2003S		–	0.3	–	pF
	LBE2009S; LCE2009S		–	0.6	–	pF
C_{ce}	collector-emitter capacitance	$V_{CE} = 18\text{ V}; V_{EB} = 1.5\text{ V};$ $I_E = I_C = 0; f = 1\text{ MHz}$				
	LBE2003S		–	0.45	–	pF
	LBE2009S; LCE2009S		–	0.6	–	pF
C_{eb}	emitter-base capacitance	$V_{CB} = 10\text{ V}; V_{EB} = 1\text{ V};$ $I_E = I_C = 0; f = 1\text{ MHz}$				
	LBE2003S		–	1.7	–	pF
	LBE2009S; LCE2009S		–	3.3	–	pF

LCE2009S IS A MAINTENANCE TYPE - NOT RECOMMENDED FOR NEW DESIGNS; SEE INDEX SECTION OF SC15

NPN microwave power transistors

LBE2003S; LBE2009S;
LCE2009S**Table 1** Scattering parameters LBE2003S: $V_{CE} = 18\text{ V}$; $I_C = 30\text{ mA}$ (V_{CE} and I_C regulated); $T_{mb} = 25\text{ °C}$; $Z_0 = 50\text{ }\Omega$; typical values. (The figures given between brackets are values in dB).

f (MHz)	S ₁₁		S ₂₁		S ₁₂		S ₂₂	
	MAGNITUDE (ratio)	ANGLE (deg)	MAGNITUDE (ratio)	ANGLE (deg)	MAGNITUDE (ratio)	ANGLE (deg)	MAGNITUDE (ratio)	ANGLE (deg)
500	0.56	-143	0.037 (-28.6)	41	9.50 (19.6)	101	0.56	-34
600	0.55	-154	0.040 (-28.0)	39	8.28 (18.4)	93	0.51	-35
700	0.55	-164	0.040 (-27.9)	40	7.13 (17.1)	88	0.50	-36
800	0.55	-171	0.041 (-27.7)	40	6.35 (16.1)	82	0.49	-37
900	0.55	-178	0.043 (-27.4)	41	5.69 (15.1)	77	0.47	-38
1000	0.55	176	0.045 (-26.9)	40	5.14 (14.2)	72	0.46	-39
1100	0.55	170	0.048 (-26.4)	40	4.72 (13.5)	68	0.46	-39
1200	0.55	165	0.051 (-25.9)	41	4.37 (12.8)	64	0.45	-41
1300	0.56	159	0.056 (-25.1)	41	4.05 (12.2)	60	0.44	-44
1400	0.55	158	0.060 (-24.5)	41	3.76 (11.5)	57	0.45	-46
1500	0.55	149	0.062 (-24.2)	40	3.52 (10.9)	53	0.43	-48
1600	0.55	146	0.065 (-23.8)	42	3.33 (10.5)	50	0.43	-50
1700	0.56	142	0.068 (-23.3)	42	3.15 (10.0)	46	0.43	-53
1800	0.57	137	0.070 (-23.1)	41	2.96 (9.4)	42	0.43	-54
1900	0.57	132	0.072 (-22.9)	40	2.80 (8.9)	39	0.43	-56
2000	0.58	128	0.074 (-22.7)	40	2.66 (8.5)	36	0.42	-57
2200	0.60	121	0.081 (-21.8)	39	2.43 (7.7)	28	0.41	-61
2400	0.62	114	0.091 (-20.8)	37	2.24 (7.0)	23	0.40	-67
2600	0.64	108	0.099 (-20.1)	36	2.08 (6.4)	16	0.39	-75
2800	0.66	102	0.105 (-19.6)	33	1.90 (5.6)	10	0.38	-82
3000	0.68	96	0.108 (-19.4)	31	1.79 (5.1)	4	0.39	-87
3200	0.71	92	0.124 (-18.7)	29	1.63 (4.3)	-2	0.37	-94
3400	0.73	89	0.125 (-18.0)	27	1.58 (4.0)	-7	0.40	-101
3600	0.75	86	0.137 (-17.3)	25	1.46 (3.3)	-13	0.39	-112
3800	0.76	82	0.142 (-17.0)	23	1.40 (2.9)	-18	0.38	-120
4000	0.77	79	0.149 (-16.6)	20	1.31 (2.3)	-24	0.38	-128
4200	0.78	75	0.155 (-16.2)	17	1.25 (1.9)	-28	0.38	-133
4400	0.80	73	0.167 (-15.5)	15	1.20 (1.6)	-34	0.39	-142
4600	0.81	69	0.177 (-15.0)	12	1.14 (1.1)	-38	0.39	-151
4800	0.81	68	0.187 (-14.6)	10	1.10 (0.8)	-43	0.42	-159
5000	0.81	65	0.194 (-14.3)	6	1.04 (0.4)	-47	0.44	-165
5200	0.80	60	0.203 (-13.8)	4	1.03 (0.3)	-53	0.47	-169
5400	0.81	56	0.219 (-13.2)	-1	0.98 (-0.2)	-57	0.48	-175
5600	0.81	51	0.229 (-12.8)	-3	0.97 (-0.3)	-62	0.49	-178
5800	0.81	48	0.243 (-12.3)	-8	0.92 (-0.7)	-68	0.51	-171
6000	0.80	44	0.245 (-12.2)	-12	0.90 (-0.9)	-72	0.55	-165

NPN microwave power transistors

LBE2003S; LBE2009S;
LCE2009S**Table 2** Scattering parameters LBE2009S; LCE2009S: $V_{CE} = 18$ V; $I_C = 110$ mA (V_{CE} and I_C regulated); $T_{mb} = 25$ °C; $Z_0 = 50$ Ω ; typical values. (The figures given between brackets are values in dB).

f (MHz)	S ₁₁		S ₂₁		S ₁₂		S ₂₂	
	MAGNITUDE (ratio)	ANGLE (deg)	MAGNITUDE (ratio)	ANGLE (deg)	MAGNITUDE (ratio)	ANGLE (deg)	MAGNITUDE (ratio)	ANGLE (deg)
500	0.70	177	0.029 (-30.7)	50	7.55 (17.6)	83	0.25	-48
600	0.70	171	0.033 (-29.6)	51	6.43 (16.2)	77	0.22	-50
700	0.70	168	0.036 (-29.0)	53	5.46 (14.6)	73	0.23	-52
800	0.70	163	0.039 (-28.4)	54	4.80 (13.6)	68	0.22	-54
900	0.71	159	0.041 (-27.8)	54	4.27 (12.6)	64	0.22	-56
1000	0.71	155	0.045 (-27.0)	55	3.84 (11.7)	60	0.21	-59
1100	0.71	151	0.049 (-26.2)	54	3.53 (11.0)	56	0.21	-62
1200	0.71	148	0.054 (-25.4)	54	3.27 (10.3)	52	0.21	-65
1300	0.71	144	0.060 (-24.5)	53	3.01 (9.6)	48	0.20	-74
1400	0.72	143	0.066 (-23.6)	54	2.80 (9.0)	45	0.20	-79
1500	0.72	136	0.070 (-23.1)	52	2.61 (8.3)	41	0.21	-80
1600	0.72	133	0.075 (-22.5)	53	2.47 (7.9)	38	0.21	-83
1700	0.72	130	0.080 (-21.9)	51	2.33 (7.3)	34	0.22	-87
1800	0.73	127	0.084 (-21.5)	49	2.18 (6.8)	30	0.22	-90
1900	0.73	123	0.087 (-21.2)	48	2.05 (6.3)	26	0.22	-94
2000	0.74	120	0.090 (-20.9)	46	1.97 (5.9)	23	0.22	-97
2200	0.75	114	0.100 (-20.0)	43	1.78 (5.0)	15	0.22	-109
2400	0.77	108	0.112 (-19.0)	40	1.63 (4.3)	10	0.21	-122
2600	0.79	103	0.123 (-18.2)	37	1.51 (3.6)	2	0.24	-133
2800	0.80	97	0.129 (-17.8)	33	1.36 (2.7)	-4	0.25	-143
3000	0.81	92	0.134 (-17.5)	30	1.28 (2.1)	-11	0.27	-151
3200	0.83	88	0.143 (-16.9)	26	1.15 (1.2)	-17	0.28	-163
3400	0.85	85	0.152 (-16.4)	24	1.10 (0.9)	-21	0.30	-173
3600	0.86	82	0.163 (-15.8)	20	1.00 (0)	-28	0.34	178
3800	0.87	79	0.168 (-15.5)	17	0.96 (-0.4)	-32	0.37	173
4000	0.88	75	0.175 (-15.2)	14	0.88 (-1.1)	-39	0.41	168
4200	0.88	71	0.180 (-14.9)	11	0.83 (-1.6)	-42	0.42	162
4400	0.89	69	0.193 (-14.3)	8	0.79 (-2.1)	-48	0.45	155
4600	0.90	66	0.200 (-14.0)	5	0.74 (-2.6)	-51	0.48	149
4800	0.90	64	0.211 (-13.5)	2	0.71 (-3.0)	-56	0.52	145
5000	0.90	61	0.214 (-13.4)	-2	0.66 (-3.6)	-59	0.55	144

LCE2009S IS A MAINTENANCE TYPE - NOT RECOMMENDED FOR NEW DESIGNS; SEE INDEX SECTION OF SC15

NPN microwave power transistors

LBE2003S; LBE2009S;
LCE2009S

APPLICATION INFORMATION

Microwave performance for LBE2003S up to $T_{mb} = 25\text{ }^{\circ}\text{C}$ in a common emitter class-A test circuit; note 1.

MODE OF OPERATION	f (GHz)	V_{CE} (V) ⁽²⁾	I_C (mA) ⁽²⁾	P_{L1} (mW) ⁽³⁾	G_{po} (dB) ⁽⁴⁾	Z_i (Ω)	Z_L (Ω)
Class-A (CW)	2	18	30	≥ 200 (23) typ. 250 (24)	≥ 10 typ. 11	$6.2 + j30$	$17.5 + j7$

Notes

1. Circuit consists of prematching circuit boards in combination with complementary input and output slug tuners.
2. I_C and V_{CE} regulated.
3. Load power for 1 dB compressed power gain.
4. Low level power gain associated with P_{L1} .

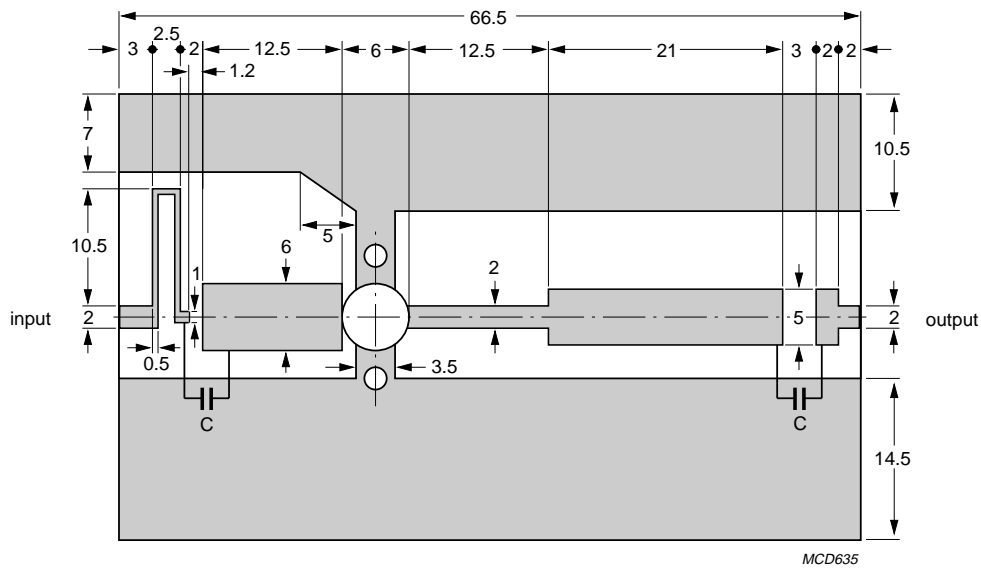

Dimensions in mm.

Striplines on a double copper-clad printed-circuit board with PTFE fibreglass dielectric ($\epsilon_r = 2.54$); thickness: 0.8 mm.

Fig.7 Prematching test circuit board for 2 GHz.

LCE2009S IS A MAINTENANCE TYPE - NOT RECOMMENDED FOR NEW DESIGNS; SEE INDEX SECTION OF SC15

NPN microwave power transistors

LBE2003S; LBE2009S;
LCE2009S

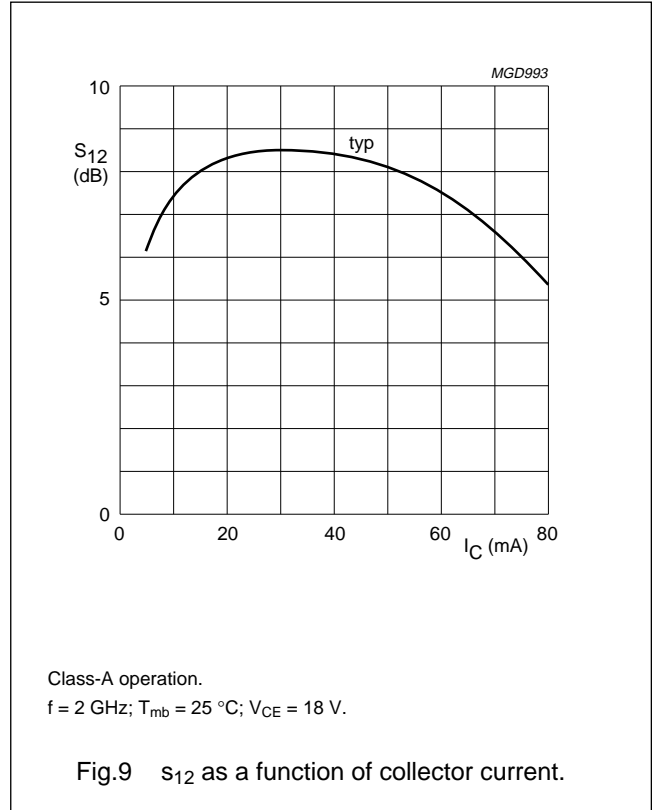
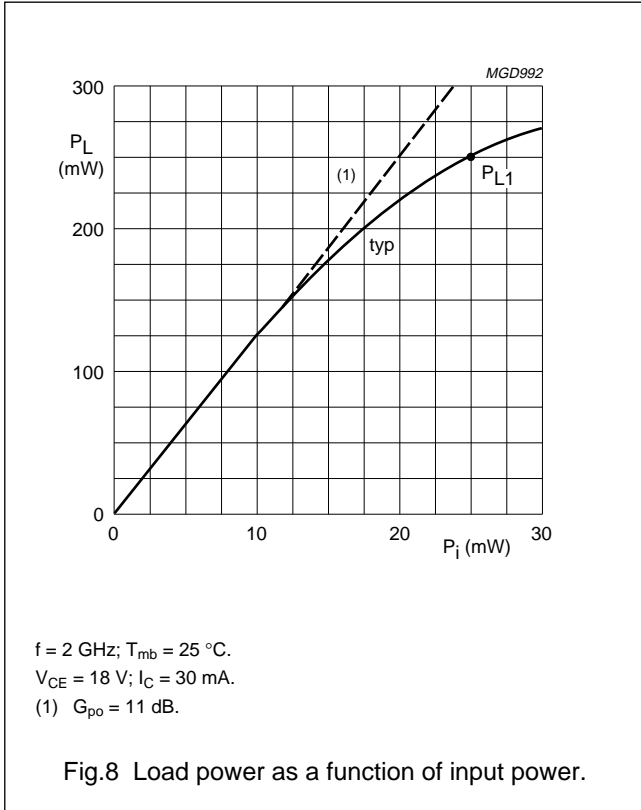

LCE2009S IS A MAINTENANCE TYPE - NOT RECOMMENDED FOR NEW DESIGNS; SEE INDEX SECTION OF SC15

NPN microwave power transistors

LBE2003S; LBE2009S;
LCE2009S

Microwave performance for LBE2009S; LCE2009S up to $T_{mb} = 75\text{ }^\circ\text{C}$ in a common emitter class-A test circuit; note 1.

MODE OF OPERATION	f (GHz)	V _{CE} (V) ⁽²⁾	I _C (mA) ⁽²⁾	P _{L1} (mW) ⁽³⁾	G _{po} (dB) ⁽⁴⁾	Z _i (Ω)	Z _L (Ω)
Class-A (CW)	2	18	110	≥700 (28.5) typ. 900 (29.5)	≥9 typ. 9.8	7.5 + j14.5	17.5 + j38.5

Notes

1. Circuit consists of prematching circuit boards in combination with complementary input and output slug tuners.
2. I_C and V_{CE} regulated.
3. Load power for 1 dB compressed power gain.
4. Low level power gain associated with P_{L1}.

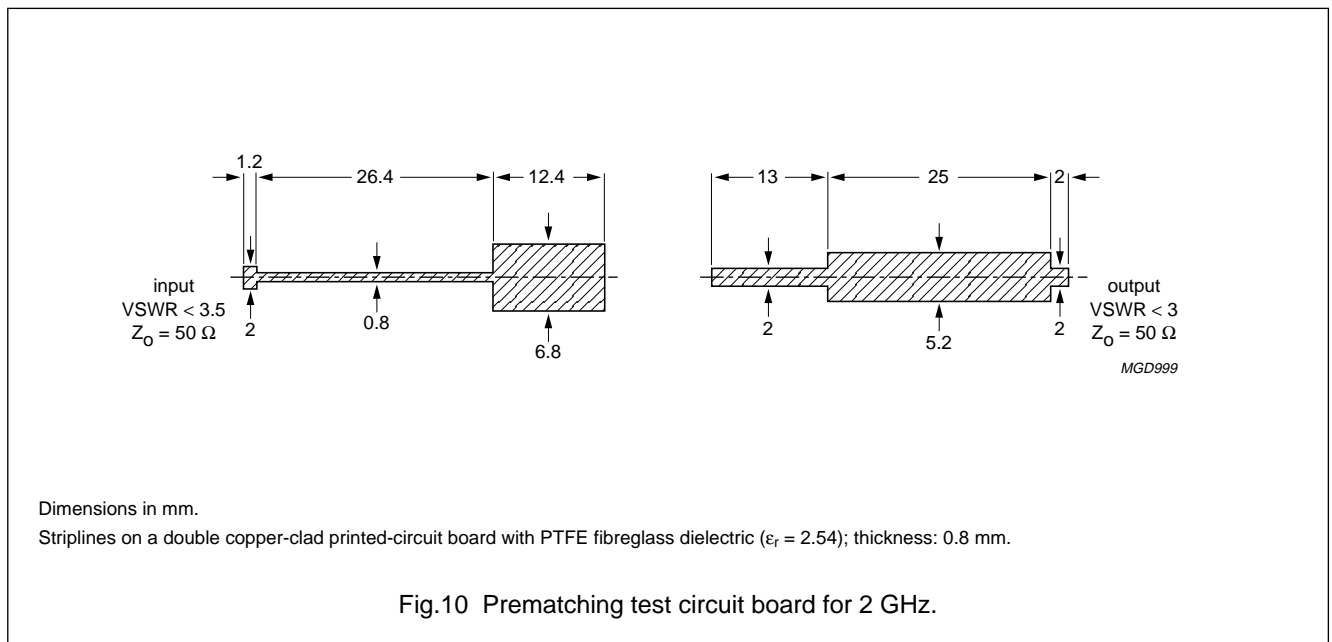

LCE2009S IS A MAINTENANCE TYPE - NOT RECOMMENDED FOR NEW DESIGNS; SEE INDEX SECTION OF SC15

NPN microwave power transistors

LBE2003S; LBE2009S;
LCE2009S

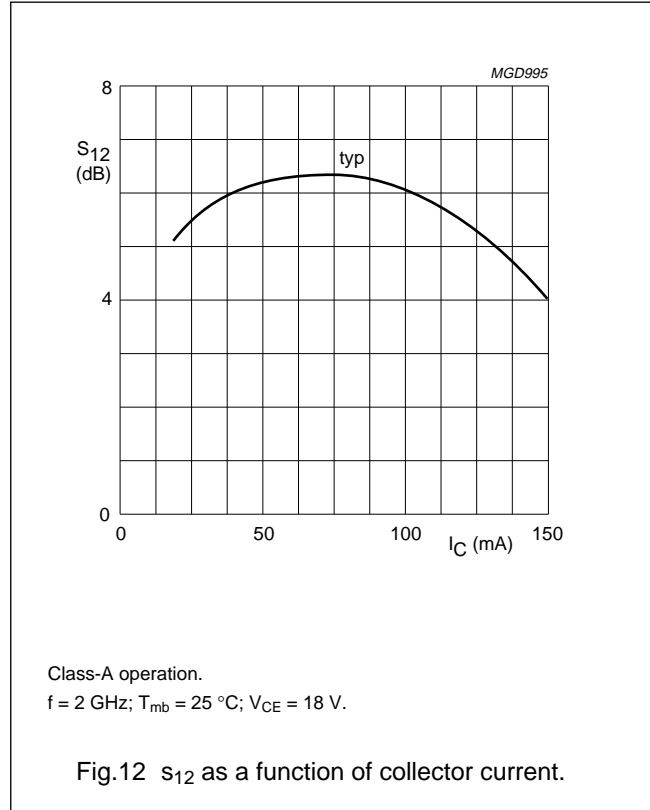
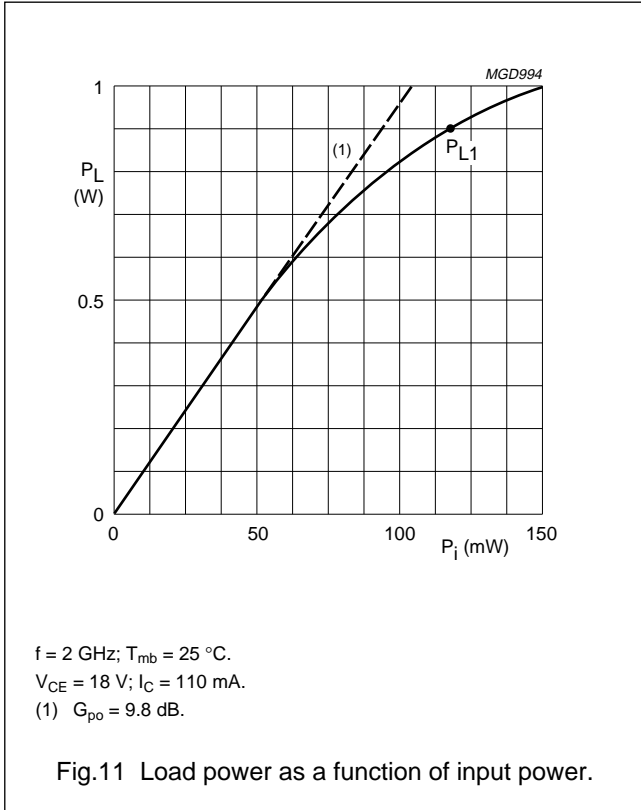

LCE2009S IS A MAINTENANCE TYPE - NOT RECOMMENDED FOR NEW DESIGNS; SEE INDEX SECTION OF SC15

NPN microwave power transistors

LBE2003S; LBE2009S;
LCE2009S

PACKAGE OUTLINES

Studless ceramic package; 4 leads

SOT441A

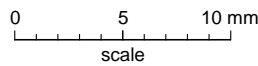
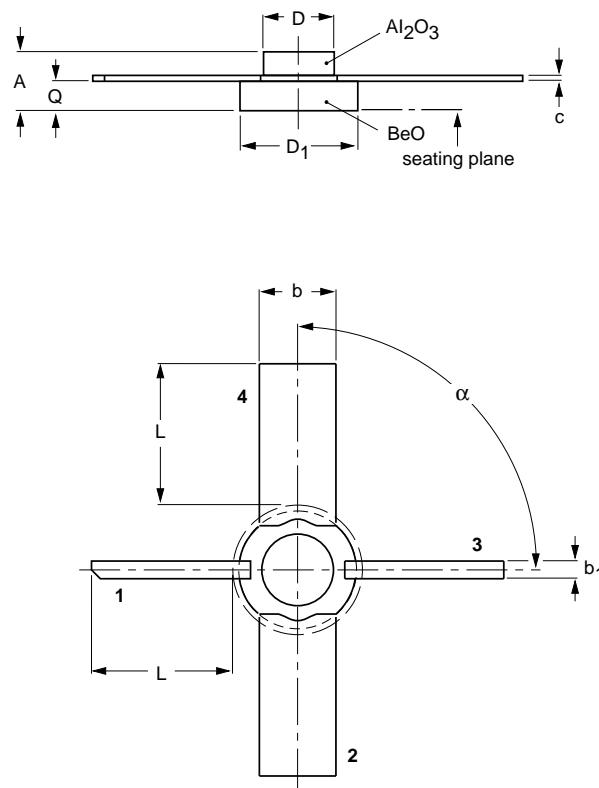

DIMENSIONS (mm are the original dimensions)

UNIT	A max.	b	b ₁	c	D	D ₁	L min.	Q	α
mm	2.4	3.2	0.75	0.125	3.38 3.08	5.28 5.12	6	1.3 1.0	90°

Note

1. This device incorporates naked beryllium oxide, the dust of which is toxic.

OUTLINE VERSION	REFERENCES			EUROPEAN PROJECTION	ISSUE DATE
	IEC	JEDEC	EIAJ		
SOT441A					97-02-28

NPN microwave power transistors

LBE2003S; LBE2009S;
LCE2009S

Studded ceramic package; 4 leads

SOT442A

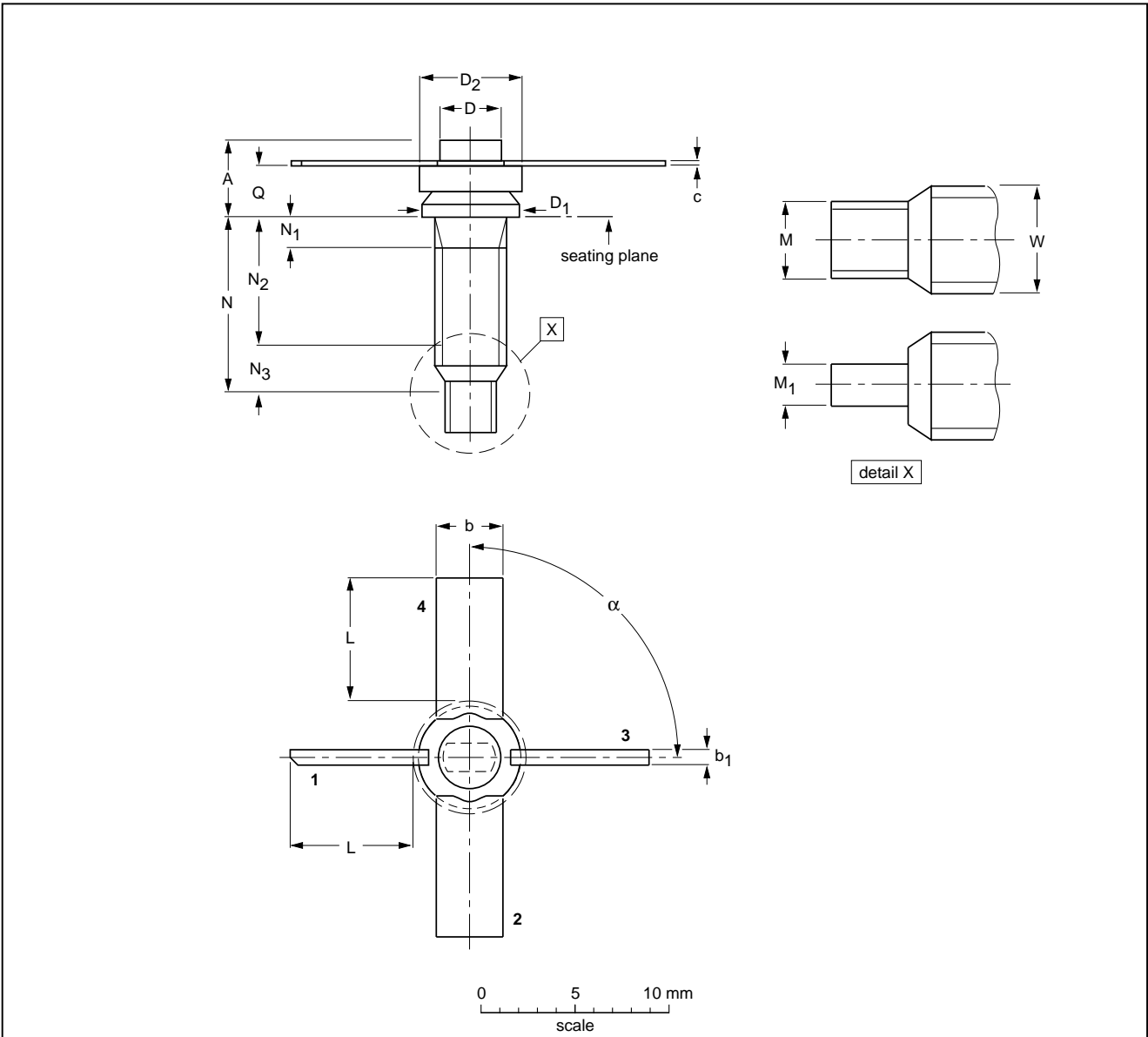

DIMENSIONS (mm are the original dimensions)

UNIT	A max.	b	b ₁	c	D	D ₁	D ₂	L min.	M	M ₁	N max.	N ₁ max.	N ₂	N ₃ min	Q	W	α
mm	4.0	3.2	0.75	0.125	3.38 3.08	5.25 5.10	5.28 5.12	6	3.27 3.01	1.6 1.4	12.5	1.6	8.5 7.5	2.9	2.80 2.50	8-32 UNC	90°

Note

1. This device incorporates naked beryllium oxide, the dust of which is toxic.

OUTLINE VERSION	REFERENCES				EUROPEAN PROJECTION	ISSUE DATE
	IEC	JEDEC	EIAJ			
SOT442A						97-02-28

NPN microwave power transistors
**LBE2003S; LBE2009S;
LCE2009S**

DEFINITIONS

Data Sheet Status	
Objective specification	This data sheet contains target or goal specifications for product development.
Preliminary specification	This data sheet contains preliminary data; supplementary data may be published later.
Product specification	This data sheet contains final product specifications.
Limiting values	
Limiting values given are in accordance with the Absolute Maximum Rating System (IEC 134). Stress above one or more of the limiting values may cause permanent damage to the device. These are stress ratings only and operation of the device at these or at any other conditions above those given in the Characteristics sections of the specification is not implied. Exposure to limiting values for extended periods may affect device reliability.	
Application information	
Where application information is given, it is advisory and does not form part of the specification.	

LIFE SUPPORT APPLICATIONS

These products are not designed for use in life support appliances, devices, or systems where malfunction of these products can reasonably be expected to result in personal injury. Philips customers using or selling these products for use in such applications do so at their own risk and agree to fully indemnify Philips for any damages resulting from such improper use or sale.

NPN microwave power transistors

LBE2003S; LBE2009S;
LCE2009S

NOTES

Philips Semiconductors – a worldwide company

Argentina: see South America

Australia: 34 Waterloo Road, NORTH RYDE, NSW 2113,
Tel. +61 2 9805 4455, Fax. +61 2 9805 4466

Austria: Computerstr. 6, A-1101 WIEN, P.O. Box 213,
Tel. +43 1 60 101, Fax. +43 1 60 101 1210

Belarus: Hotel Minsk Business Center, Bld. 3, r. 1211, Volodarski Str. 6,
220050 MINSK, Tel. +375 172 200 733, Fax. +375 172 200 773

Belgium: see The Netherlands

Brazil: see South America

Bulgaria: Philips Bulgaria Ltd., Energoproject, 15th floor,
51 James Bourchier Blvd., 1407 SOFIA,
Tel. +359 2 689 211, Fax. +359 2 689 102

Canada: PHILIPS SEMICONDUCTORS/COMPONENTS,
Tel. +1 800 234 7381

China/Hong Kong: 501 Hong Kong Industrial Technology Centre,
72 Tat Chee Avenue, Kowloon Tong, HONG KONG,
Tel. +852 2319 7888, Fax. +852 2319 7700

Colombia: see South America

Czech Republic: see Austria

Denmark: Prags Boulevard 80, PB 1919, DK-2300 COPENHAGEN S,
Tel. +45 32 88 2636, Fax. +45 31 57 1949

Finland: Sinikalliontie 3, FIN-02630 ESPOO,
Tel. +358 9 615800, Fax. +358 9 61580/xxx

France: 4 Rue du Port-aux-Vins, BP317, 92156 SURESNES Cedex,
Tel. +33 1 40 99 6161, Fax. +33 1 40 99 6427

Germany: Hammerbrookstraße 69, D-20097 HAMBURG,
Tel. +49 40 23 53 60, Fax. +49 40 23 536 300

Greece: No. 15, 25th March Street, GR 17778 TAVROS/ATHENS,
Tel. +30 1 4894 339/239, Fax. +30 1 4814 240

Hungary: see Austria

India: Philips INDIA Ltd, Shivsagar Estate, A Block, Dr. Annie Besant Rd.
Worli, MUMBAI 400 018, Tel. +91 22 4938 541, Fax. +91 22 4938 722

Indonesia: see Singapore

Ireland: Newstead, Clonskeagh, DUBLIN 14,
Tel. +353 1 7640 000, Fax. +353 1 7640 200

Israel: RAPAC Electronics, 7 Kehilat Saloniki St, TEL AVIV 61180,
Tel. +972 3 645 0444, Fax. +972 3 649 1007

Italy: PHILIPS SEMICONDUCTORS, Piazza IV Novembre 3,
20124 MILANO, Tel. +39 2 6752 2531, Fax. +39 2 6752 2557

Japan: Philips Bldg 13-37, Kohnan 2-chome, Minato-ku, TOKYO 108,
Tel. +81 3 3740 5130, Fax. +81 3 3740 5077

Korea: Philips House, 260-199 Itaewon-dong, Yongsan-ku, SEOUL,
Tel. +82 2 709 1412, Fax. +82 2 709 1415

Malaysia: No. 76 Jalan Universiti, 46200 PETALING JAYA, SELANGOR,
Tel. +60 3 750 5214, Fax. +60 3 757 4880

Mexico: 5900 Gateway East, Suite 200, EL PASO, TEXAS 79905,
Tel. +9-5 800 234 7381

Middle East: see Italy

Netherlands: Postbus 90050, 5600 PB EINDHOVEN, Bldg. VB,
Tel. +31 40 27 82785, Fax. +31 40 27 88399

New Zealand: 2 Wagener Place, C.P.O. Box 1041, AUCKLAND,
Tel. +64 9 849 4160, Fax. +64 9 849 7811

Norway: Box 1, Manglerud 0612, OSLO,
Tel. +47 22 74 8000, Fax. +47 22 74 8341

Philippines: Philips Semiconductors Philippines Inc.,
106 Valero St. Salcedo Village, P.O. Box 2108 MCC, MAKATI,
Metro MANILA, Tel. +63 2 816 6380, Fax. +63 2 817 3474

Poland: Ul. Lukiska 10, PL 04-123 WARSZAWA,
Tel. +48 22 612 2831, Fax. +48 22 612 2327

Portugal: see Spain

Romania: see Italy

Russia: Philips Russia, Ul. Usatcheva 35A, 119048 MOSCOW,
Tel. +7 095 755 6918, Fax. +7 095 755 6919

Singapore: Lorong 1, Toa Payoh, SINGAPORE 1231,
Tel. +65 350 2538, Fax. +65 251 6500

Slovakia: see Austria

Slovenia: see Italy

South Africa: S.A. PHILIPS Pty Ltd., 195-215 Main Road Martindale,
2092 JOHANNESBURG, P.O. Box 7430 Johannesburg 2000,
Tel. +27 11 470 5911, Fax. +27 11 470 5494

South America: Rua do Rocio 220, 5th floor, Suite 51,
04552-903 São Paulo, SÃO PAULO - SP, Brazil,
Tel. +55 11 821 2333, Fax. +55 11 829 1849

Spain: Balmes 22, 08007 BARCELONA,
Tel. +34 3 301 6312, Fax. +34 3 301 4107

Sweden: Kottbygatan 7, Akalla, S-16485 STOCKHOLM,
Tel. +46 8 632 2000, Fax. +46 8 632 2745

Switzerland: Allmendstrasse 140, CH-8027 ZÜRICH,
Tel. +41 1 488 2686, Fax. +41 1 481 7730

Taiwan: Philips Semiconductors, 6F, No. 96, Chien Kuo N. Rd., Sec. 1,
TAIPEI, Taiwan Tel. +886 2 2134 2870, Fax. +886 2 2134 2874

Thailand: PHILIPS ELECTRONICS (THAILAND) Ltd.,
209/2 Sanpavuth-Bangna Road Prakanong, BANGKOK 10260,
Tel. +66 2 745 4090, Fax. +66 2 398 0793

Turkey: Talatpasa Cad. No. 5, 80640 GÜLTEPE/ISTANBUL,
Tel. +90 212 279 2770, Fax. +90 212 282 6707

Ukraine: PHILIPS UKRAINE, 4 Patrice Lumumba str., Building B, Floor 7,
252042 KIEV, Tel. +380 44 264 2776, Fax. +380 44 268 0461

United Kingdom: Philips Semiconductors Ltd., 276 Bath Road, Hayes,
MIDDLESEX UB3 5BX, Tel. +44 181 730 5000, Fax. +44 181 754 8421

United States: 811 East Arques Avenue, SUNNYVALE, CA 94088-3409,
Tel. +1 800 234 7381

Uruguay: see South America

Vietnam: see Singapore

Yugoslavia: PHILIPS, Trg N. Pasica 5/v, 11000 BEOGRAD,
Tel. +381 11 625 344, Fax. +381 11 635 777

For all other countries apply to: Philips Semiconductors, Marketing & Sales Communications,
Building BE-p, P.O. Box 218, 5600 MD EINDHOVEN, The Netherlands, Fax. +31 40 27 24825

Internet: <http://www.semiconductors.philips.com>

© Philips Electronics N.V. 1997

SCA53

All rights are reserved. Reproduction in whole or in part is prohibited without the prior written consent of the copyright owner.

The information presented in this document does not form part of any quotation or contract, is believed to be accurate and reliable and may be changed without notice. No liability will be accepted by the publisher for any consequence of its use. Publication thereof does not convey nor imply any license under patent- or other industrial or intellectual property rights.

Printed in The Netherlands

127147/00/02/pp16

Date of release: 1997 Mar 03

Document order number: 9397 750 01864

Let's make things better.