

查询CDLL935供应商

捷多邦, 专业PCB打样工厂, 24小时加急出货

- 1N935BUR-1, 1N937BUR-1 and 1N938BUR-1 AVAILABLE IN JAN, JANTX, JANTXV AND JANS PER MIL-PRF-19500/156
- TEMPERATURE COMPENSATED ZENER REFERENCE DIODES
- LEADLESS PACKAGE FOR SURFACE MOUNT
- 9.0 VOLT NOMINAL ZENER VOLTAGE
- METALLURGICALLY BONDED, DOUBLE PLUG CONSTRUCTION

1N935BUR-1 thru 1N938BUR-1
and
CDLL935 thru CDLL938B

MAXIMUM RATINGS

Operating Temperature: -65°C to +175°C
Storage Temperature: -65°C to +175°C
DC Power Dissipation: 500mW @ +50°C
Power Derating: 4 mW / °C above +50°C

REVERSE LEAKAGE CURRENT

$I_R = 10 \mu A @ 25^\circ C \text{ \& } V_R = 6 \text{ Vdc}$

ELECTRICAL CHARACTERISTICS @ 25°C, unless otherwise specified.

| CDI TYPE NUMBER | ZENER VOLTAGE $V_Z @ I_{ZT}$ | ZENER TEST CURRENT I_{ZT} | MAXIMUM ZENER IMPEDANCE Z_{ZT} | VOLTAGE TEMPERATURE STABILITY ΔV_{ZT} MAXIMUM (Note 2) | TEMPERATURE RANGE | EFFECTIVE TEMPERATURE COEFFICIENT |
|-----------------|---------------------------------|--------------------------------|-------------------------------------|---|-------------------|-----------------------------------|
| | VOLTS | mA | OHMS | mV | °C | % / °C |
| CDLL935 | 8.55 - 9.45 | 7.5 | 20 | 67 | 0 to + 75 | 0.01 |
| CDLL935A | 8.55 - 9.45 | 7.5 | 20 | 139 | -55 to +100 | 0.01 |
| CDLL935B | 8.55 - 9.45 | 7.5 | 20 | 184 | -55 to +150 | 0.01 |
| CDLL936 | 8.55 - 9.45 | 7.5 | 20 | 34 | 0 to + 75 | 0.005 |
| CDLL936A | 8.55 - 9.45 | 7.5 | 20 | 70 | -55 to +100 | 0.005 |
| CDLL936B | 8.55 - 9.45 | 7.5 | 20 | 92 | -55 to +150 | 0.005 |
| CDLL937 | 8.55 - 9.45 | 7.5 | 20 | 13 | 0 to + 75 | 0.002 |
| CDLL937A | 8.55 - 9.45 | 7.5 | 20 | 28 | -55 to +100 | 0.002 |
| CDLL937B | 8.55 - 9.45 | 7.5 | 20 | 37 | -55 to +150 | 0.002 |
| CDLL938 | 8.55 - 9.45 | 7.5 | 20 | 6.7 | 0 to + 75 | 0.001 |
| CDLL938A | 8.55 - 9.45 | 7.5 | 20 | 13.9 | -55 to +100 | 0.001 |
| CDLL938B | 8.55 - 9.45 | 7.5 | 20 | 19 | -55 to +150 | 0.001 |

NOTE 1 Zener impedance is derived by superimposing on I_{ZT} A 60Hz rms a.c. current equal to 10% of I_{ZT} .

NOTE 2 The maximum allowable change observed over the entire temperature range i.e., the diode voltage will not exceed the specified mV at any discrete temperature between the established limits, per JEDEC standard No.5.

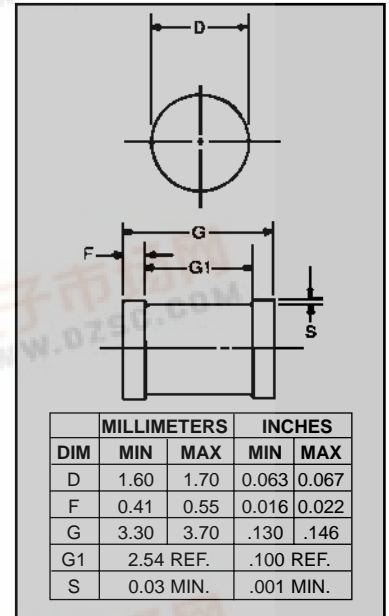

FIGURE 1

DESIGN DATA

CASE: DO-213AA, Hermetically sealed glass case. (MELF, SOD-80, LL34)

LEAD FINISH: Tin / Lead

POLARITY: Diode to be operated with the banded (cathode) end positive.

MOUNTING POSITION: Any.

MOUNTING SURFACE SELECTION:
The Axial Coefficient of Expansion (COE) Of this Device is Approximately +6PPM/°C. The COE of the Mounting Surface System Should Be Selected To Provide A Suitable Match With This Device.



COMPENSATED DEVICES INCORPORATED

22 COREY STREET, MELROSE, MASSACHUSETTS 02176
PHONE (781) 665 1071 FAX (781) 665 7370

CDLL935 thru CDLL938B

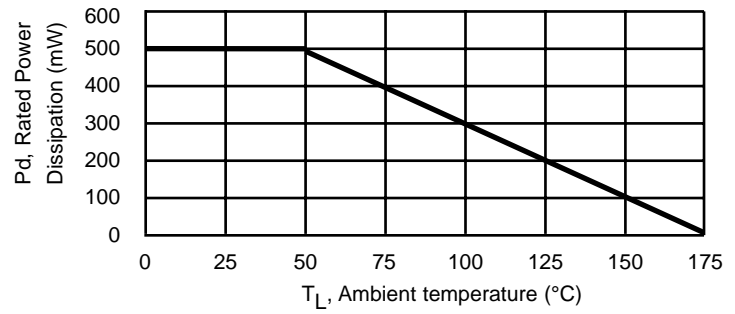

**FIGURE 2
POWER DERATING CURVE**

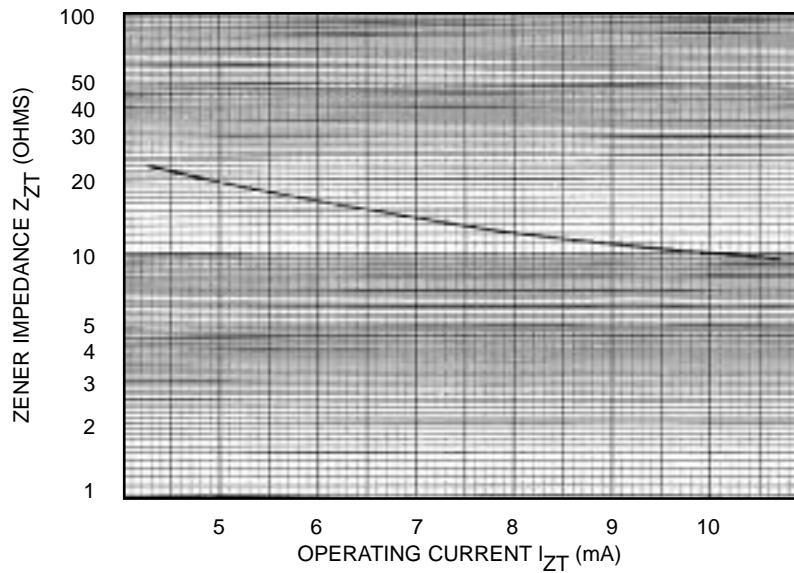

**FIGURE 3
ZENER IMPEDANCE VS. OPERATING CURRENT**

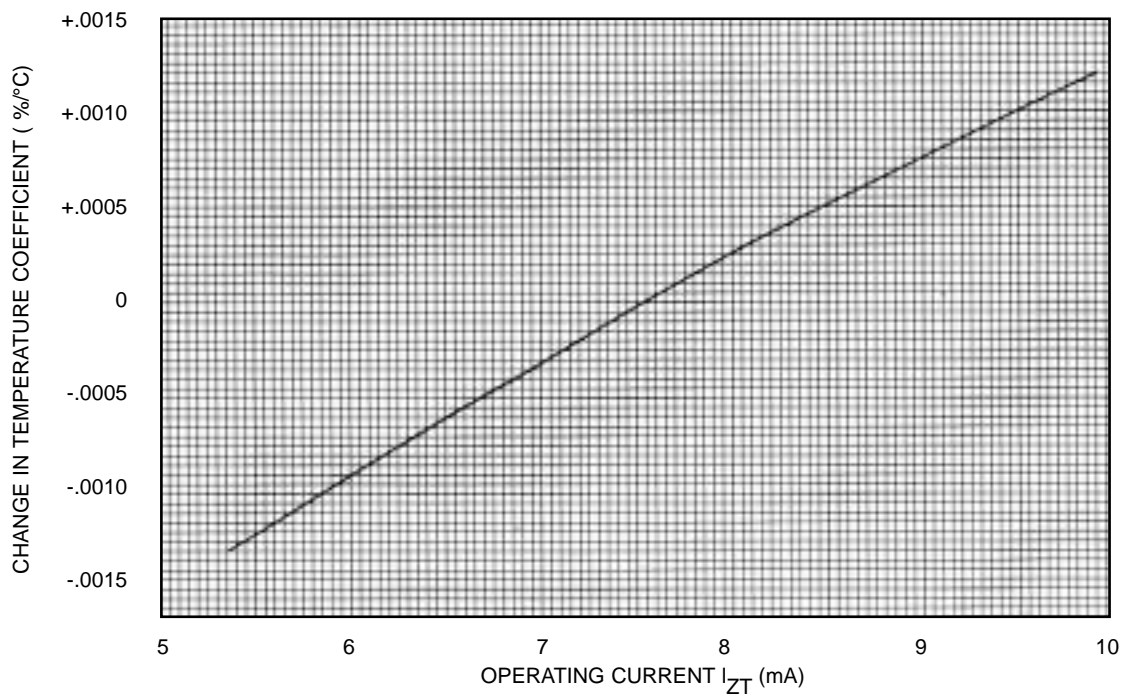

**FIGURE 4
TYPICAL CHANGE OF TEMPERATURE COEFFICIENT
WITH CHANGE IN OPERATING CURRENT**