



Single Mode Connectorized Laser Diode (Low Power)

Technical Data

LST0605-FC-A

Features

- 1300 nm Single Mode
- Hermetic Construction
- Industry Standard FC Connector
- Low Threshold Current
- Integral InGaAs PIN Monitor Photodiode
- High Reliability
- Connectorized for Ease of Use

Description

The LST0605-FC-A series has been developed for low cost, coolerless low power single mode applications using the FC style connector. Both the buried heterostructure laser and the monitor photodiode are manufactured using the Hewlett-Packard MOVPE process.

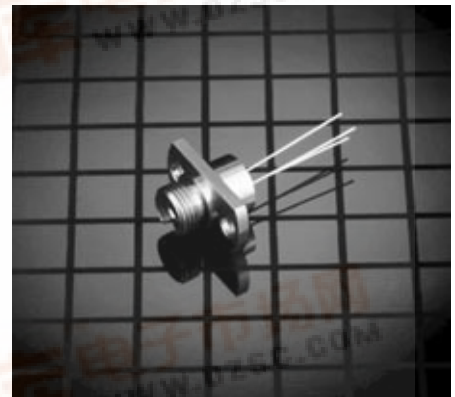

Applications

- Fiber Optic Laser Transmitter
- Instrumentation
- Subscriber Loop Communications Systems
- Low Cost Single Mode Fiber Systems
- SM-FDDI
- E-O Convertors

Laser Safety Warning

This device is a Class IIIb (3b) Laser Product. It may emit invisible laser radiation from an open optical port. To avoid possible eye damage do not look into an open optical port during laser operation. Do not exceed specified operating limits.

Absolute Maximum Ratings

Absolute maximum limits mean that no catastrophic damage will occur if the product is subjected to these ratings for short periods, provided each limiting parameter is in isolation and all other parameters have values within the performance specification. It should not be assumed that limiting values of more than one parameter can be applied to the product at the same time.

Parameter	Minimum	Typical	Maximum	Units
Forward Current	-	-	100	mA
Reverse Current	-	-	100	μ A
Reverse Voltage	-	-	2.0	V
Operating Temperature (Case)	-20	-	70	$^{\circ}$ C
Storage Temperature	-40	-	85	$^{\circ}$ C

Performance Specification (Tc 25 $^{\circ}$ C)

Parameter	Minimum	Typical	Maximum	Units	Notes
Peak Wavelength	1270	1300	1330	nm	1
Spectral Width (FWHM)	-	5	10	nm	1
Optical Output	100	200	500	μ W	1, 2
Forward Voltage	-	1.2	1.4	V	1
Rise Time	-	0.5	1.0	ns	3
Fall Time	-	0.5	1.0	ns	3
Wavelength Temperature Coefficient	-	0.45	0.6	nm/ $^{\circ}$ C	4
Threshold Current	5	14	25	mA	5
Monitor Current	60	125	270	μ A	6
Dark Current	-	-	50	nA	7
Tracking Error	-	\pm 0.5	\pm 1.5	dB	8

Notes:

1. CW, Ith + 15 mA.
2. Final test limits using single mode FC terminated fiber.
3. 10/90% rise, 90/10% fall, Ibias = Ith.
4. Im const.
5. CW.
6. -5 V photodiode bias.
7. -5 V bias, Pout = 0 μ W.
8. -20 $^{\circ}$ C/+70 $^{\circ}$ C, Im const.

LST0605-FC-A Package Drawing

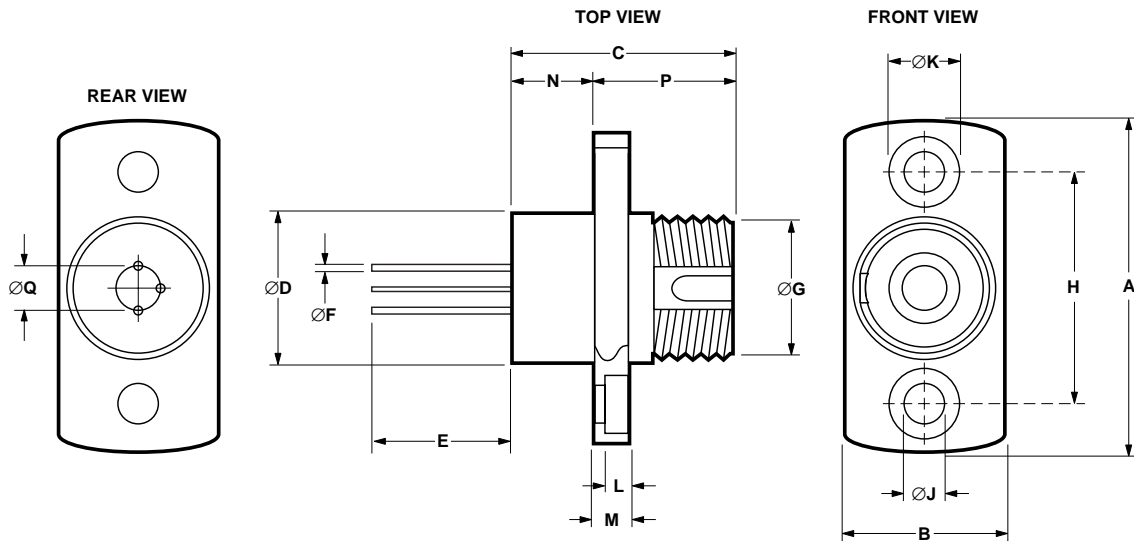

CONNECTIONS

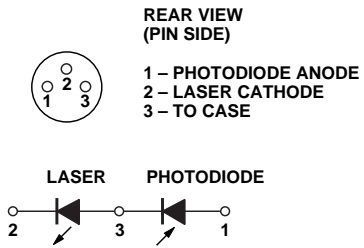

DIM.	MIN.	MAX.	DIM.	MIN.	MAX.
A	-	19.50	$\varnothing J$	2.08	2.32
B	-	9.50	$\varnothing K$	-	4.20
C	-	13.0	L	-	1.65
$\varnothing D$	-	9.0	M	-	2.20
E	12.0	-	N	-	4.80
$\varnothing F$	0.41	0.47	P	-	8.20
$\varnothing G$	M8 x 0.75		$\varnothing Q$	2.54 NOM.	
H	13.35	13.55			

ALL DIMENSIONS IN MILLIMETERS

Ordering Information

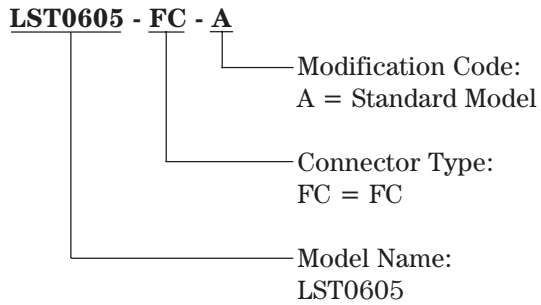

Handling Precautions

1. The LST0605 can be damaged by current surges or overvoltage.
2. Power supply transient precautions should be taken.
3. Normal handling precautions for electrostatic sensitive devices should be taken.

CDRH Certification

Hewlett-Packard Ltd
Whitehouse Road
Ipswich, Suffolk IP1 5PB
England

Manufactured: ____ Serial No. ____
Model No. _____

This product conforms to the applicable requirements of 21 CFR 1040 at the date of manufacture.

Laser Warning

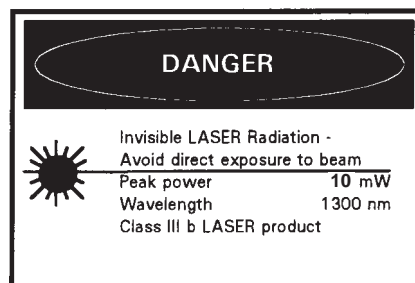

Single Mode SC Connectorized Laser Transmitter Module

Technical Data

LST062X-SC-A

Features

- **1300 nm Single Mode**
- **Industry Standard SC Connector**
- **High Reliability**
- **Connectorized for Ease of Use**
- **Convenient Variety of 4 Pin Configurations**
- **Hermetic Construction**
- **Wide Operating Temperature -40°C to +85°C**
- **Modulation Capability up to 622 Mbit/s**
- **SONET SR/IR up to OC12 SDH STM1 and 4 Compliant**
- **Laser Eye Safety Classifications: CDRH Class 1 Compliant IEC825-1 Class 3A**
- **200 µW Fiber Coupled Power**

Applications

- **Telecommunications**
- **Fiber in the Loop**
- **Inter/Intra Office**
- **SONET/SDH**
- **Datacommunications**
- **Switches**

Description

The LST062X-SC-A series is a laser transmitter, operating in the 1300 nm wavelength region. It is designed for use in short and medium distance networks with bit rates up to 622 Mbit/s.

The device features a high reliability laser diode and a monitor photodiode in a hermetic package. These are electrically connected to four pins in an industry-standard configuration.

Environmental performance is designed to be compatible with the requirements of Bellcore's TA-NWT-000983 document.

Options within the LST062X-SC-A family offer several 4 Pin configurations with pin rotational

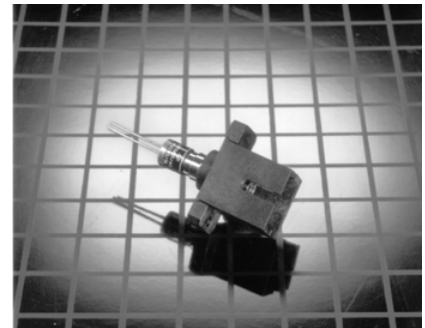

orientations designed to match existing products available on the market.

If the specific arrangement or performance you require is not listed, please contact your local representative as our highly flexible design and manufacturing processes allow both physical and electro-optical customization to meet your needs.

Laser Safety Warning

This device is a Class IIIa (3A) Laser Product. It may emit invisible laser radiation from an open optical port. To avoid possible eye damage do not look into an open optical port during laser operation. Do not exceed specified operating limits.

Absolute Maximum Ratings

Absolute maximum limits mean that no catastrophic damage will occur if the product is subjected to these ratings for short periods, provided each limiting parameter is in isolation and all other parameters have values within the performance specification. It should not be assumed that limiting values of more than one parameter can be applied to the product at the same time.

Parameter	Symbol	Conditions	Limits		Units
			Min.	Max.	
Laser Forward Current	I _f	DC	-	150	mA
Laser Reverse Current	I _r	DC	-	100	μA
Laser Reverse Voltage	V _{lr}	DC	-	2	V
Photodiode Reverse Voltage	V _r	DC	-	10	V
Photodiode Forward Current	I _{pf}	DC	-	1	mA
Operating Temperature	T _c	Pf = 200 μW	-40	+85	°C
Storage Temperature	T _s		-40	+85	°C
Relative Humidity	RH		0.0	non-condensing	%RH
Mechanical Shock		Mil Std 883D, Method 2002, Condition B			
Vibration		Mil Std 883D, Method 2007, Condition A			

Performance Specifications

Parameter	Symbol	Conditions	Limits		Units
			Min.	Max.	
LASER		CW, T _c = 25°C, Pf = 200 μW unless otherwise stated			
Threshold Current	I _{th}		7	16	mA
Peak Optical Output Power	P _f	T _c = -40°C to +85°C CW	200	-	μW
Optical Output Power	P _{th}	P _{th} = P _f @ I _{th} - 2mA	-	8	μW
Slope Efficiency		T _c = 25°C	10	25	mW/mA
		T _c = -40°C to +85°C	5	40	mW/mA
Drive Current above I _{th}	I _d	Pf = 200 μW	8	20	mA
Forward Voltage	V _f		-	1.6	V
Center Wavelength	λ _c	Note 1	1260	1360	nm
Temp. Dependence of λ _c	Dλ _c /DT	T _c = -40°C to +85°C	-	0.4	nm/°C
Linewidth	Δλ	1xs, RMS, Note 1	-	2.5	nm
Rise Time	t _r	10% to 90%: I _{th} to P _f = 200 μW	-	0.5	ns
Fall Time	t _f	90% to 10%: P _f = 200 μW to I _{th}	-	0.5	ns

Note:

1. Modulated measurements also available.

Performance Specifications (cont'd.)

Parameter	Symbol	Conditions	Limits		Units
			Min.	Max.	
MONITOR PHOTODIODE		Tc = 25°C, Vr = -5 V (Note 2) Pf = 200 μW unless otherwise stated			
Photocurrent	Im		100	1500	μA
Dark Current	Id	Pf = 0 μW	-	20	nA
Capacitance	C	1 MHz	-	10	Pf
Tracking Error	DR	Im = Im @ (Pf = 200 μW, Tc = 25°C) Tc = -40°C to +85°C	-	± 1.5	dB
Rise Time	tr	10% to 90%: Ith to Pf = 200 μW	-	2.0	ns
Fall Time	tf	90% to 10%: Pf = 200 μW to Ith	-	2.0	ns

LST0623

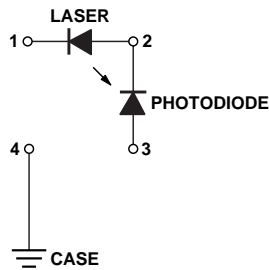

- 1 – LASER CATHODE
- 2 – LASER ANODE/MONITOR PHOTODIODE
- 3 – MONITOR ANODE (-ve)
- 4 – NO CONNECTION

LST0625

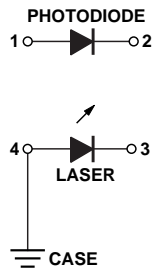

- 1 – MONITOR ANODE (-ve)
- 2 – MONITOR CATHODE (+ve)
- 3 – LASER CATHODE
- 4 – LASER ANODE

LST0627

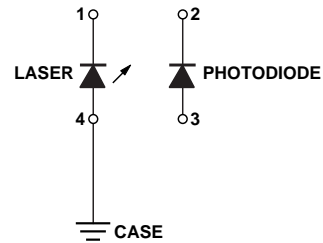

- 1 – LASER CATHODE
- 2 – MONITOR CATHODE (+ve)
- 3 – MONITOR ANODE (-ve)
- 4 – LASER ANODE

LST062X-SC-A Package Drawing

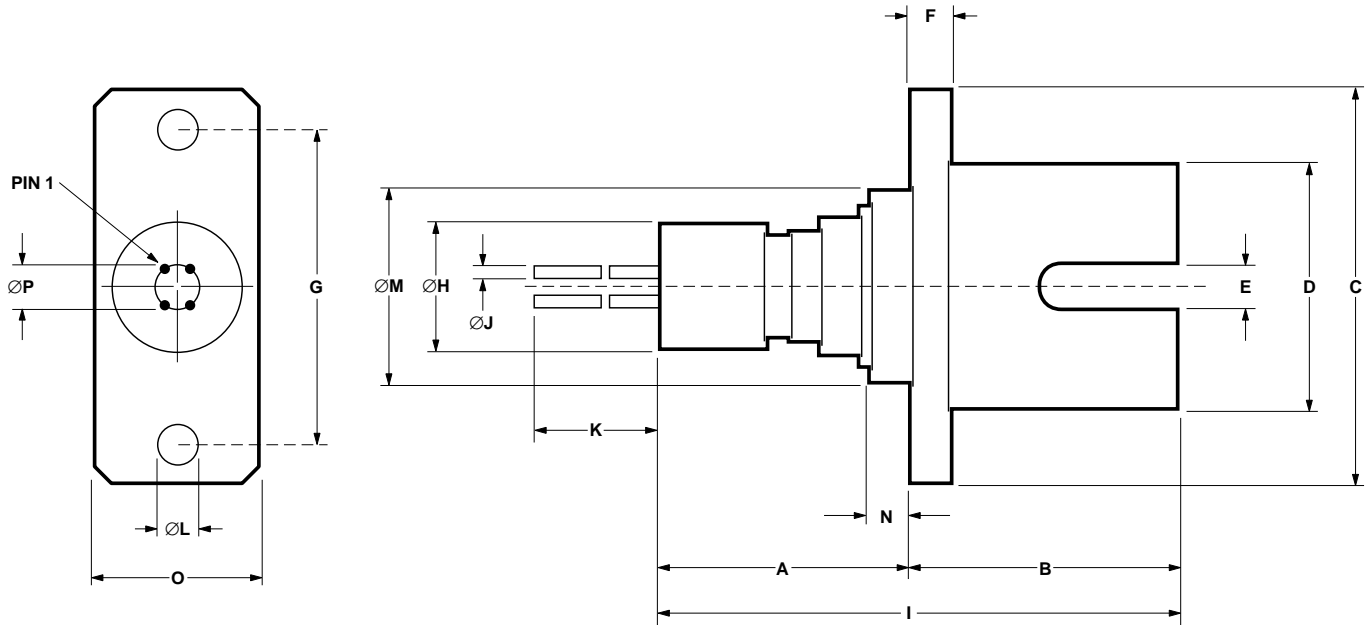

DIM.	MIN.	MAX.	DIM.	MIN.	MAX.
A	-	13.50	I	-	29.00
B	15.1	15.50	$\varnothing J$	0.41	0.49
C	21.50	22.50	K	12.00	-
D	12.60	13.00	$\varnothing L$	2.20	2.40
E	2.00	2.20	$\varnothing M$	-	8.60
F	2.90	3.10	N	-	2.60
G	17.50	18.50	O	9.20	9.40
$\varnothing H$	-	7.00	$\varnothing P$	1.90	2.10

ALL DIMENSIONS IN MILLIMETERS

Pin Outs

LST0623

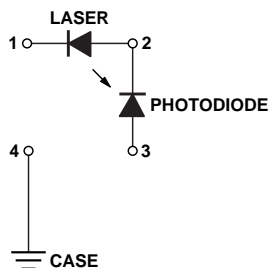

- 1 - LASER CATHODE
- 2 - LASER ANODE/MONITOR PHOTODIODE
- 3 - MONITOR ANODE (-ve)
- 4 - NO CONNECTION

LST0625

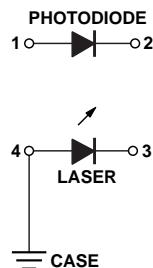

- 1 - MONITOR ANODE (-ve)
- 2 - MONITOR CATHODE (+ve)
- 3 - LASER CATHODE
- 4 - LASER ANODE

LST0627

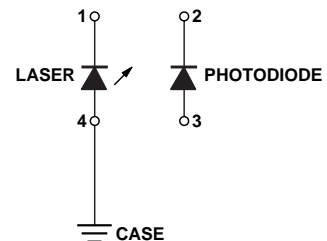

- 1 - LASER CATHODE
- 2 - MONITOR CATHODE (+ve)
- 3 - MONITOR ANODE (-ve)
- 4 - LASER ANODE

Ordering Information

LST062X - SC - A

Allowed Model Names:
LST0623-SC-A
LST0625-SC-A
LST0627-SC-A

Pin Outs - See Drawings:

3
5
7

Handling Precautions

1. The LST062X can be damaged by current surges or overvoltage.
2. Power supply transient precautions should be taken.
3. Normal handling precautions for electrostatic sensitive devices should be taken.

CDRH Certification

Hewlett-Packard Ltd
Whitehouse Road
Ipswich, Suffolk IP1 5PB
England

Manufactured: _____ Serial No. _____
Model No. _____

This product conforms to the applicable requirements of 21 CFR 1040 at the date of manufacture.

Laser Warning



INVISIBLE LASER RADIATION
DO NOT STARE INTO BEAM OR VIEW
DIRECTLY WITH OPTICAL INSTRUMENTS
CLASS 3A LASER PRODUCT
Peak Power 12 mW
Wavelength 1300 nm

IEC825-1 1993