



- **Minimum Depth Indicator - Less Than 2.5" (60mm) of Space Required Behind the Panel**
- **Stackable Mounting Bracket Included for Easy Installation**
- **3-1/2 Digit, 0.5" (12.7mm) High LCD Display with Optional Negative Image, Bright Red Backlighting**
- **Limited Range Display Scaling**
- **Standard Screw Terminals for Easy Installation**
- **Six Current Ranges: 200 μ A, 2mA, 20mA, 200mA, 2A, 5A**
- **85-250VAC or 9-32VDC Power Supply**



Simpson's Mini-Max Current Indicators provide high quality, accuracy and reliability in a compact, 60mm deep case. Units offer 3-1/2 digit, 0.5" (12.7mm) LCD display and are available with a bright red, negative image backlight option. All units feature user-selectable decimal point, auto zero and limited scaling capabilities.

A unique mounting bracket is provided to allow for vertical or horizontal stacking of multiple indicators. All Mini-Max units feature a 3/64 DIN, high-impact plastic case. The standard units have a clear viewing window, and the units with optional negative image, red backlighting have a red window.

Installation and Panel Cutout

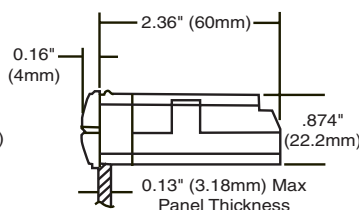
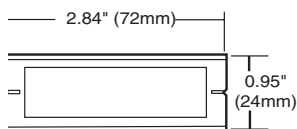
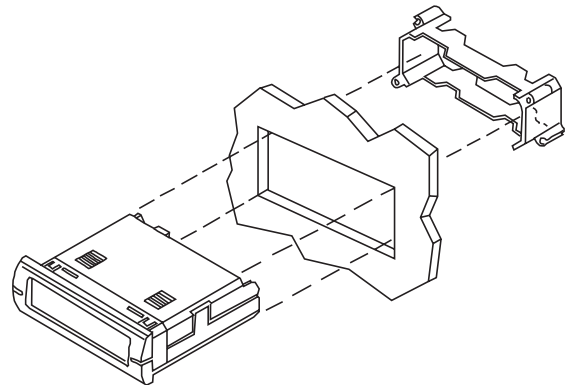
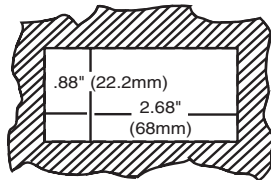
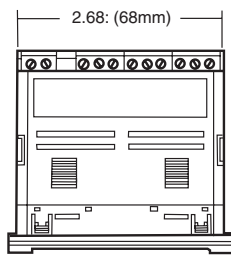

Mounting Requirements

Insert the Mini-Max through the panel, and then slide the mounting bracket on to the Mini-Max. The mounting bracket allows Mini-Max units to be stacked side-to-side or top-to-bottom and to maintain the DIN standard panel arrangements in 24mm by 72mm multiples. Panel cutout instructions for stacking multiple units are provided under "stacking features."

Specifications

DISPLAY

Type: 7-segment LCD
Height: 0.5" (12.7mm)
Decimal point: 3-position programmable
Overrange indication: Most significant digit = "1"
Backlighting: Optional negative image, red backlighting
Polarity: Auto with "-" indication, "+" implied

POWER REQUIREMENTS

AC Volt: 85-250VAC @40-440Hz
DC Volt: 9-32VDC
Power Consumption:
 85-250VAC: 2.5VA min/4VA max
 9-32VDC: 1.5VA min/3VA max
Rated Circuit to Ground Voltage: 750VRMS

ACCURACY @ 25°C

±(0.5% of reading + 5 count)

ENVIRONMENTAL

Operating Temperature: 0 to 55°C
Storage Temperature: -10 to 60°C
Relative Humidity: 0 to 85% non condensing @ 40°C
Temperature Coefficient:
 (± 0.02% of input ± 0.2 digits)/°C
Warmup time: Less than 20 minutes

NOISE REJECTION

NMRR: 60dB, 50/60Hz
CMRR: (w/1KΩ unbalanced @ 60Hz): 90dB min

ANALOG TO DIGITAL CONVERSION

Technique: Integrating
Rate: 3 samples/second-typical

MECHANICAL

Bezel: 0.95" x 2.84" (24mm x 72mm)
Depth: 2.36" (60mm)
Panel cutout: 0.88" x 2.68"
 (22.2mm x 68mm)
Weight: 3.5oz (99g)
Case Material:
 94-0, UL-rated, glass-filled thermoplastic

INPUTS: AC Current

Range	Resolution	Voltage Drop	Max Input (unfused)
200µA	100nA	200mV	10mA
2mA	1µA	200mV	40mA
20mA	10µA	200mV	100mA
200mA	100µA	200mV	400mA
2A	1mA	200mV	3A
5A	10mA	50mV	6A

Wiring Display

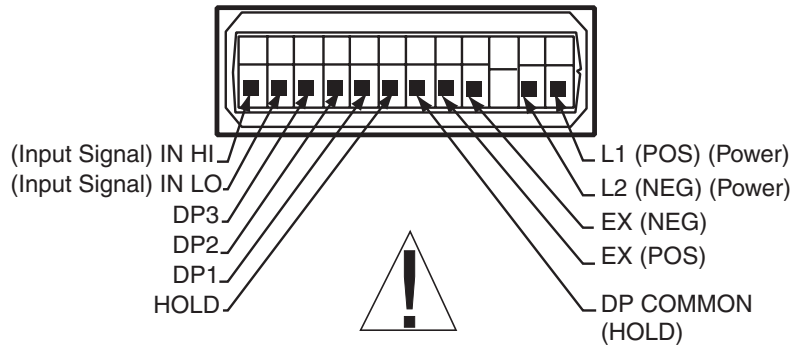

These instruments are designed for maximum safety to the operator when mounted in a panel according to instructions. They are not to be used unmounted or for exploratory measurements in unknown circuits.

- Decimal Point:** To select a decimal point, connect the appropriate DP pin (DP1, DP2, or DP3) to the DP COMMON (HOLD). Unused DP inputs may remain unconnected (open).
- Display Hold:** Connect HOLD to DP COMMON (HOLD). If this feature is not required, the DP COMMON (HOLD) pin may remain unconnected (open).
- Input Signal:** Connect the IN HI and IN LO to the signal to be monitored.
- Input Power:** Connect power to the L1 and L2 terminals. For AC powered units, L1 and L2 are not polarized. **For 9-32 DC powered units, L1 must be positive with respect to L2.**

Display Scaling

Mini-Max indicators have limited-range coarse and fine adjustments for display scaling. There are no optional connections required for these to function. The "COARSE" calibration R12 will allow a limited range of scaling values. The meter can be scaled down to 1/2 the value of the input or scaled up to 2 times the value of the input or a maximum reading of 1.999, whichever is lower. Example: a 2 Amp input has a maximum reading of 1.999 counts, so you can't double the 2 amps, but you can make 1 AMP to read 1.9999. The "FINE" calibration R9 allows for an approximate range of 1% of the "coarse" calibration. Apply full scale input to the meter. Adjust R12 to be within 1% of the desired scaled value, then use R9 to obtain the final desired result.

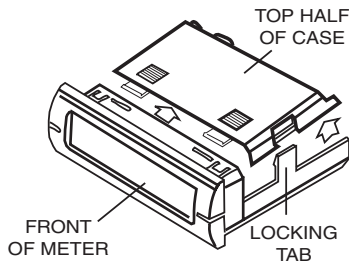

Using a screwdriver or thumbnail, spread tab on each side of case to unlock top half. Lift rear top half and slide away from front of meter.

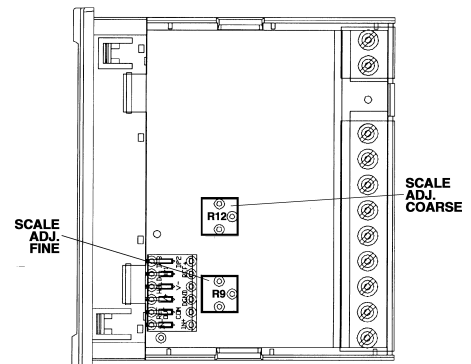

Note: Any physical damage to the meter during calibration will void the warranty

Stacking Features

The mounting brackets, included with every Mini-Max, can be connected together. Multiple units can be mounted in a single opening, allowing perfect alignment.

To punch one hole for multiple units, be sure to adjust the standard panel cutout dimensions as shown here; otherwise the meters will not fit properly in the hole.

Mounting multiple units is quick and easy. Install the first meter (bottom unit first if stacking vertically). Position the next mounting bracket snugly against the first one, and slide the second meter into place. Repeat for remaining units.

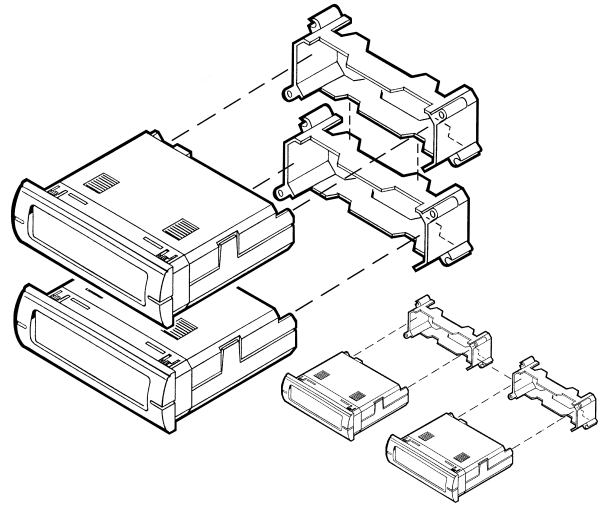

Vertical

Standard cutout

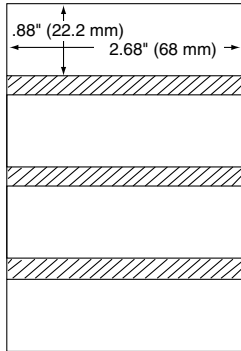

.071" (1.8 mm)
Add to standard
when stacking

Vertical

Horizontal

Standard cutout



.16" (4.0mm)
Add to standard when stacking

Backlight Option and Decimal Point Selection

Negative image, bright red backlighting is available in the Mini-Max. This illumination allows the unit to be read in low light areas. Backlighting power is supplied by the Mini-Max, so no additional external power is required.

Decimal point selection is accomplished by connecting the appropriate DP terminal to the DP Common terminal.

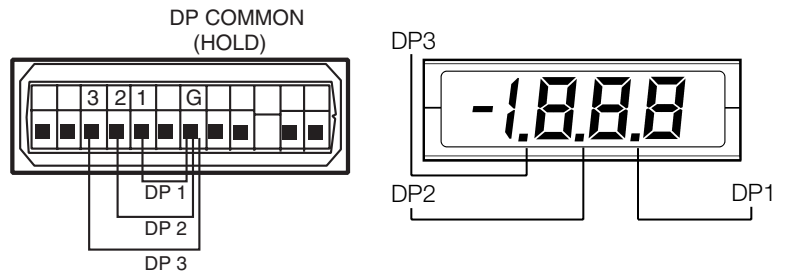

Excitation Output

Excitation output is available in the Mini-Max for powering external transmitters or transducers. Excitation is available from the EX POS and EX NEG terminals. This source is isolated from the measurement input as well as the input power circuits. The voltages available are 12VDC or 24VDC, with a maximum load current of 25 milliamps. This feature eliminates the need to mount an external DC power source for transducers or sensors used in your application.

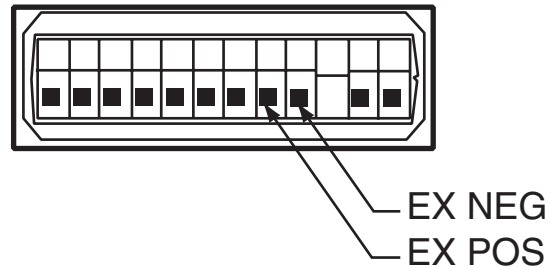

Do not exceed an excitation
load current of 25mA!

Application Example

A company needs to monitor the power supply voltage (120VAC), load current (50 amps) and frequency (60Hz) of an AC motor.

Voltage: A Mini-Max 200 Volt AC meter is installed in parallel with the power supply.

Current: A Mini-Max 5 Amp AC meter is attached to a 50:5 amp Donut Current Transformer. The meter must be scaled to display 50.0 when 5 amps are applied. R9 and R12 are adjusted until the correct value is displayed. The meter is connected to the Donut, and the negative line is fed through the donut.

Frequency: A Mini-Max 200Hz Frequency meter is installed in parallel with the power supply and motor. The wiring for the volt meter can be split to the frequency meter as long as the voltage will not exceed 750 volts AC.

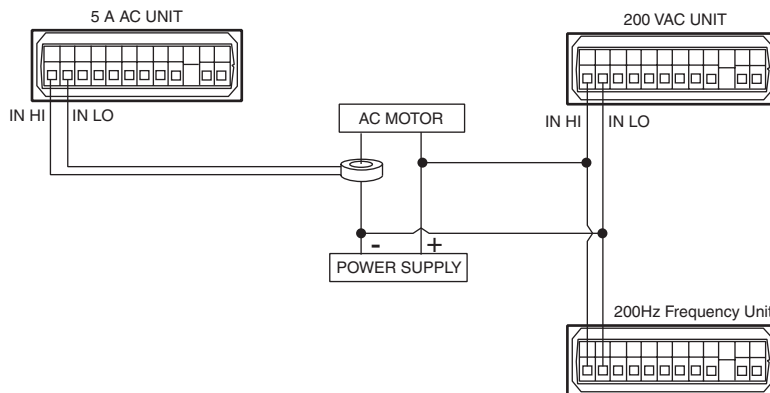

Ordering Information

Your Mini-Max Current Indicator can be configured by making an entry for each box.

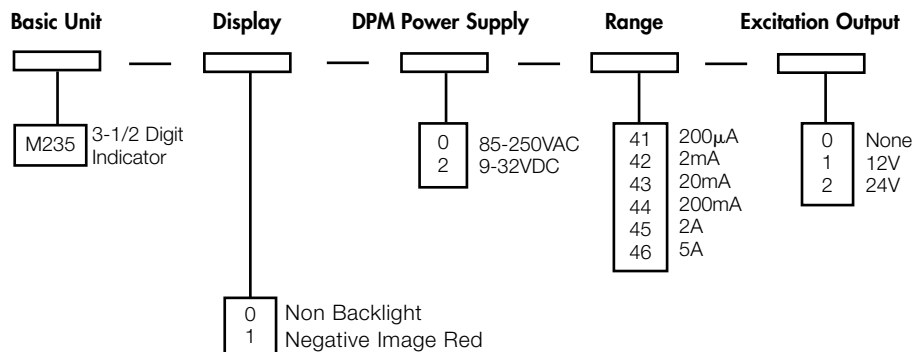

Note: Models for DC current, process, DC voltage, AC TRMS voltage, AC frequency and temperature are also available.

Note: Special scaling is available from the factory at the time of ordering

Safety Symbols



The WARNING sign denotes a hazard. It calls attention to a procedure, practice, or the like, which, if not correctly performed or adhered to, could result in personal injury.



The CAUTION sign denotes a hazard. It calls attention to an operating procedure, practice, or the like, which, if not correctly adhered to, could result in damage to or destruction of part or all of the instrument.

Accessories

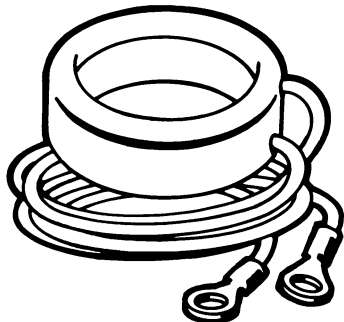

Donut Current Transformers enable the Mini-Max to monitor AC current up to 1999 amps. The Donut (also known as a "Toroid") is placed around one of the legs of the device being monitored, and emits up to a 5 amp signal. The Mini-Max can be scaled to accurately display the current being monitored. Each Donut comes with 2' long secondary leads.

Ordering Information

Range/Amps		Catalog Number
Primary	Secondary	
50	5	01293
75	5	01306
100	5	01297
150	5	01298
200	5	01299
250	5	01313
300	5	01300
400	5	01305
500	5	01301
600	5	02303
750	5	02459
1000	5	02304