



MS2202

**RF & MICROWAVE TRANSISTORS
AVIONICS APPLICATIONS**

Features

- 1025 - 1150 MHz
- 35 VOLTS
- INPUT MATCHING
- P_{OUT} = 2.0 WATTS
- G_P = 9.0 dB MINIMUM
- LOW THERMAL RESISTANCE
- COMMON BASE CONFIGURATION



DESCRIPTION:

The MS2202 is a low power Class C NPN transistor specifically designed for avionics driver applications. This device is capable of withstanding an ∞:1 load VSWR at any phase angle under full rated conditions. Low RF thermal resistance and semi-automatic bonding techniques ensure high reliability and product consistency.

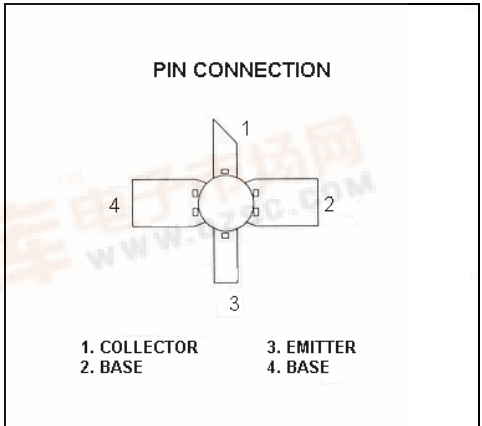

ABSOLUTE MAXIMUM RATINGS (T_{case} = 25°C)

Symbol	Parameter	Value	Unit
P _{DISS}	Power Dissipation	10	W
I _C	Device Current	250	A
V _{CC}	Collector Supply Voltage	37	V
T _J	Junction Temperature	200	°C
T _{STG}	Storage Temperature	-65 to +200	°C

Thermal Data

R _{TH(J-C)}	Junction-case Thermal Resistance	10.0	°C/W
----------------------	----------------------------------	------	------



ELECTRICAL SPECIFICATIONS (T_{case} = 25°C)
STATIC

Symbol	Test Conditions		Value			Unit
			Min.	Typ.	Max.	
BV _{CBO}	I _C = 1mA	I _E = 0 mA	45	---	---	V
BV _{EBO}	I _E = 1 mA	I _C = 0 mA	3.5	---	---	V
BV _{CER}	I _C = 5 mA	R _{BE} = 10Ω	45	---	---	V
I _{CES}	V _{CE} = 35 V		---	---	1.0	mA
HFE	V _{CE} = 5 V	I _C = 100 mA	30	---	300	---

DYNAMIC

Symbol	Test Conditions			Value			Unit
				Min.	Typ.	Max.	
P _{OUT}	f = 1025 - 1150 MHz	P _{IN} = 0.25W	V _{CC} = 35V	2.0	---	---	W
η _C	f = 1025 - 1150 MHz	P _{IN} = 0.25W	V _{CC} = 35V	35	---	---	%
G _p	f = 1025 - 1150 MHz	P _{IN} = 0.25W	V _{CC} = 35V	9.0	---	---	dB
Conditions	Pulse Width = 10μSec Duty Cycle = 1%						

IMPEDANCE DATA

FREQ	Z _{IN} (Ω)	Z _{CL} (Ω)
960 MHz	10.7 + j7.0	26.5 + j41.0
1025 MHz	15.3 + j10.0	26.0 + j43.5
1090 MHz	17.8 + j10.2	23.5 + j44.0
1150 MHz	16.8 + j15.0	20.5 + j41.5
1215 MHz	14.4 + j13.0	17.5 + j37.5

P_{IN} = 0.25 W

V_{CC} = 35 V

PACKAGE MECHANICAL DATA

PACKAGE STYLE M115

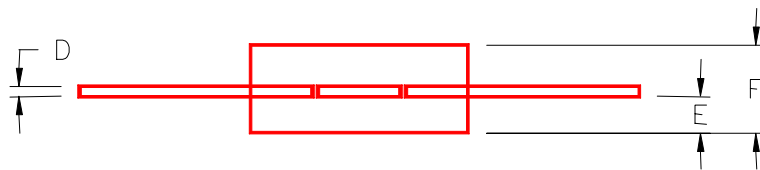
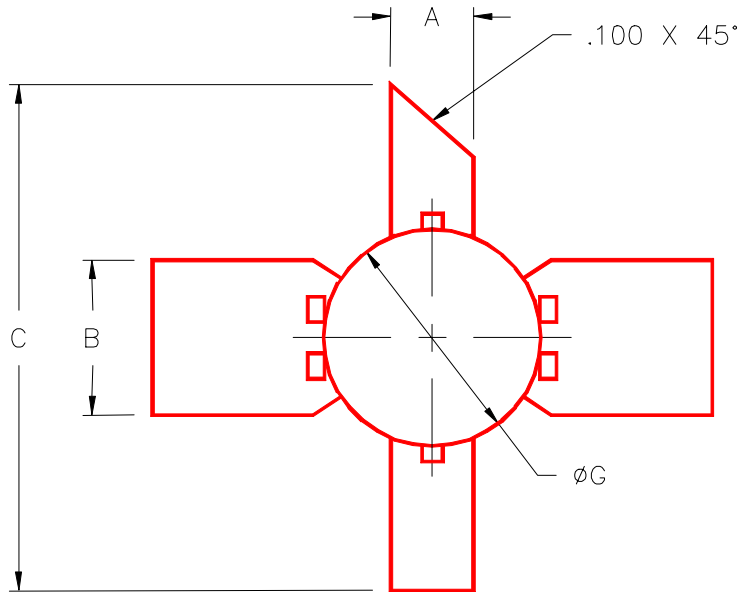

	MINIMUM INCHES/MM	MAXIMUM INCHES/MM		MINIMUM INCHES/MM	MAXIMUM INCHES/MM
A	.095/2,41	.105/2,67			
B	.195/4,95	.205/5,21			
C	1.000/25,40				
D	.004/0,10	.007/0,18			
E	.050/1,27	.065/1,65			
F	.120/3,05	.135/3,43			
G	.275/6,99	.285/7,21			