

THIS COPY IS PROVIDED ON A RESTRICTED BASIS AND IS NOT TO BE USED IN ANY WAY DETRIMENTAL TO THE INTERESTS OF PANDUIT CORP.

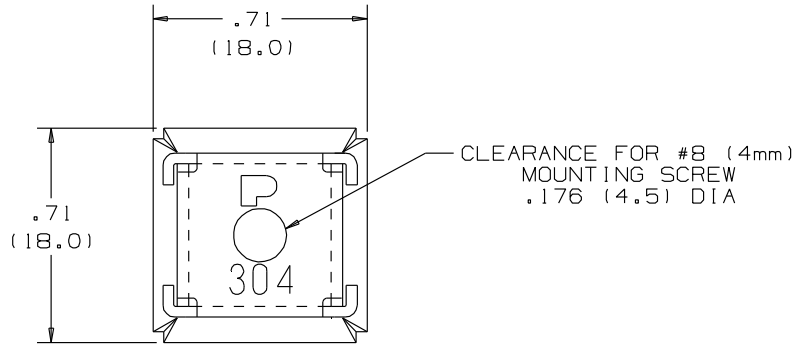
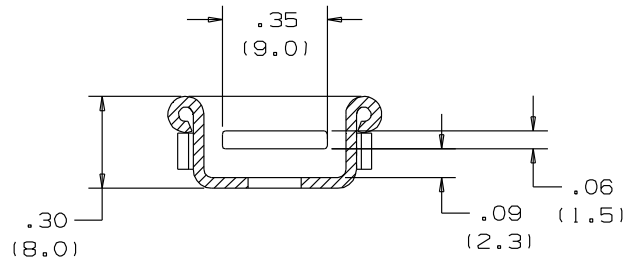

NOTES:

1. DIMENSIONAL TOLERANCES:
 .XX ±.02 (.5)
 .XXX ±.01 (.25)
2. USE WITH STD, LH & HVY CROSS SECTION MLT'S.
3. DIMS IN () ARE mm.
4. MAXIMUM SCREW HEAD HEIGHT .09 (2.3).
5. STAINLESS STEEL SCREWS ARE RECOMMENDED TO AVOID CORROSION PROBLEMS ASSOCIATED WITH DISSIMILAR METALS.
6. PACKAGE QTY: Q = 25

S41074_02

							PANDUIT CORP. TINLEY PARK, ILLINOIS			
							2-WAY METAL TIE MOUNT MTM2H			
							UNLESS OTHERWISE SPECIFIED, DIMENSIONAL TOLERANCES ARE: (.X) ± (.XXX) ± (.XX) ± ANGLES ±			
							UNLESS OTHERWISE SPECIFIED, ALL DIMENSIONS ARE GIVEN IN INCHES, THIRD ANGLE PROJECTION.			
02	8/04	JAMB	JJB	NOTE 2: ADDED THE "LH" (LIGHT-HEAVY) MLT PRODUCT FOR USE WITH MTM2H TIE MOUNT ADDED NOTE 6. CAD FILE SPEC WAS N41074SA_PCD_00	11906	CCH	JJB	DRAWN BY BJO DATE 11/11/92 CHK'D JAC	MAT'L: 304 STAINLESS STEEL	SCALE 2X DRAWING NO. S41074 DNG A SIZE
01	1/01	KMD	JAC	RELEASED	09010	CCH	JAC			
00	11/92	BO	JAC	RELEASED	01265	GP	LCA			
REV	DATE	BY	CHK	DESCRIPTION	ECN #	PM	CUST			