

1N5610
 1N5611
 1N5612, 1N5613

Features

- 1500 Watts for 1 ms Pulse Power Capability
- Small Physical Size
- Designed for MIL-STD-704A Applications

POWER ZENER
 RECTIFIER
 JAN, JANTX, JANTXV

TRANSIENT
 SUPPRESSOR
 DIODE

Description

Zener diodes with a high surge capability
 qualified to MIL-S-19500/434

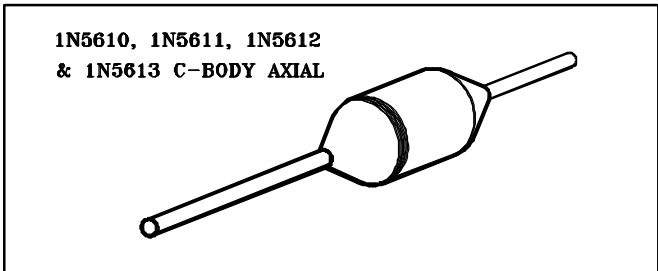

Absolute Maximum Ratings (@ 25°C unless noted)

	1N5610	1N5611	1N5612	1N5613
Forward Surge Current,	200 A	200 A	200 A	200 A
Zener Surge Current, @ 25C	32.0 A	24.0 A	19.0 A	5.7 A
Zener Surge Current @ 150C	5.5 A	4.8 A	3.2 A	1.0 A
Storage and Operating Temperature	-65C to + 175C			
Zener Voltage	See Electrical Characteristics			
Surge Power	See Graphs			

Electrical Characteristics (T = 25°C unless otherwise noted)

DEVICE TYPE	Min. Zener Voltage δ Vz @ 1Ma	Max. Zener Voltage λ Vz @ Is		MAX. Reverse Leakage Current IR @ VR		MAX. Forward V ξ @ 100 A	Typical Temp. Coefficient
	Volts	Volts	Amps	μ A	Volts	Volts	% / °C
1N5610*	33.0	47.5	32.0	5.0	30.5	4.8	.093
1N5611*	43.7	63.5	24.0	5.0	40.3	4.8	.094
1N5612*	54.0	78.5	19.0	5.0	49.0	4.8	.096
1N5613*	191	265	5.7	5.0	175	4.8	.100

NOTES: * Available as JAN, JANTX and JANTXV

δ Duration of applied current ≤ 300 ms, Duty cycle $\leq 2\%$.

λ Use a pulse which decays exponentially to 50 % of peak value during 1 ms. (See " Pulse Waveform " graph).

ξ Peak Sinusoidal surge current of 8.3 ms duration, non repetitive

**1N5610
 1N5611
 1N5612, 1N5613**

Applications

Voltage transients can be suppressed with series elements, shunt elements or a combination of both. These elements may be passive or active. For low & medium power applications, a series resistor & zener clamp offer several attractive features:

1. Simplicity of design.
2. High reliability.
3. Fast response time.

The 1N5610 series will suppress the following transients (defined by MIL-S-704A) without using any series limiting resistance; (except as noted in line #3 below)

1. All 600 V transients (category 1 in chart below).
2. All 80 V transients except those generated by the main voltage regulator (category 2 in chart below).
3. Over-voltage transients from the main voltage regulator (category 3 in chart below) will be suppressed if:
 - a. A 20 ohm series limiting resistor is used, or-
 - b. No series resistance is used & the zener is protected within 500 μ s, using (for example) an SCR crowbar.

The above statements are based on the source impedances & dv/dt characteristics as given in ARINC* spec# 413; entitled "Guidance for Aircraft Electrical Power Utilization & Transient Protection. This report further defines MIL-STD-704A in regard to large aircraft electrical systems.

These surge suppressors are useful in a variety of other applications where semiconductor devices must function in an environment subject to extremely high, but short term surges.

* ARINC stands for Aeronautical Radio Incorporated; Annapolis, Maryland 21401

Category #	Source of Trans.	Max. Amplitude	Duration of Trans.	Min. Impedance	dv over dt
1	Inductive Swtchg	600 V	$\leq 10 \mu$ s	50 ohm	---
2	BUS Switching	80 V	≤ 10 ms	15 ohm	---
3	Main Volt. Reg.	80 V	≥ 10 ms	0.2 ohm	50V/ms

**1N5610
1N5611
1N5612, 1N5613**

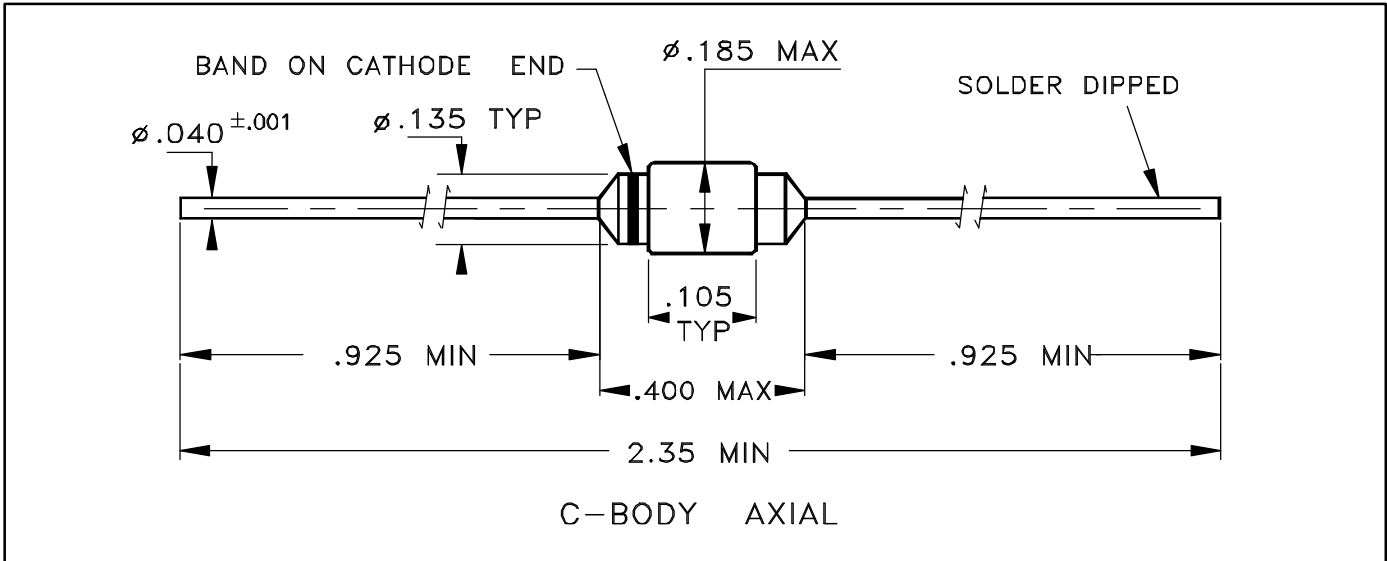

DEVICE OUTLINE

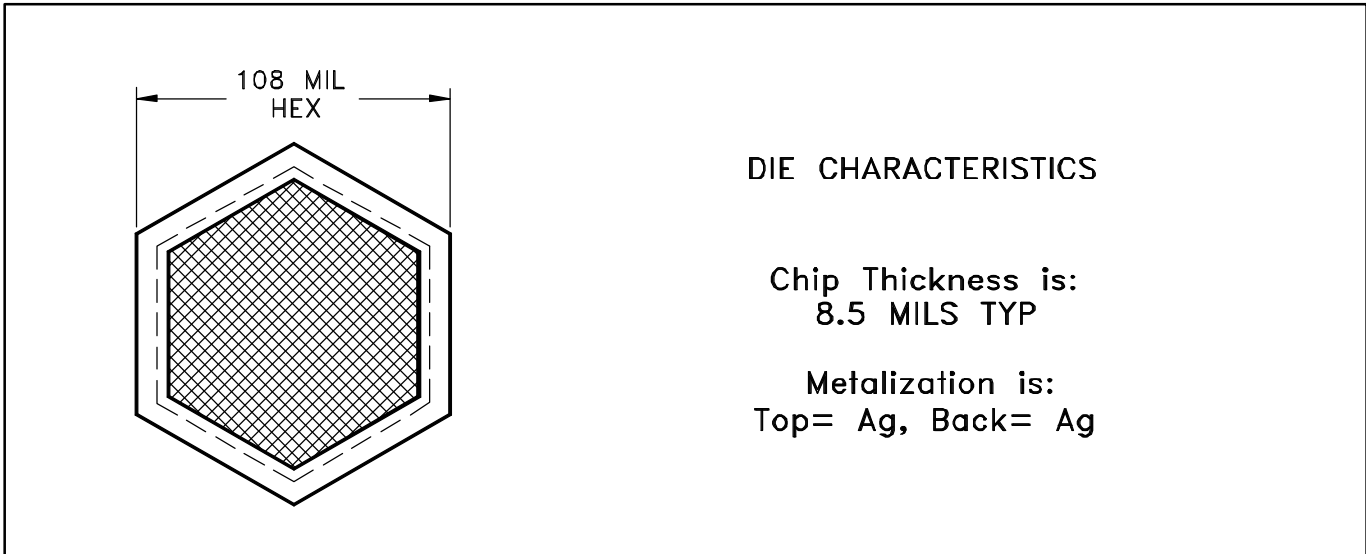

DIE OUTLINE

1N5610
1N5611
1N5612, 1N5613

Pulse Waveform

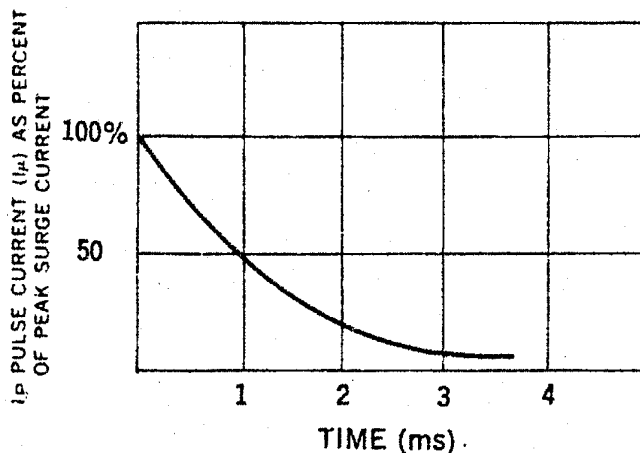

FIGURE 1

**Peak Power Rating*
vs. Ambient Temperature**

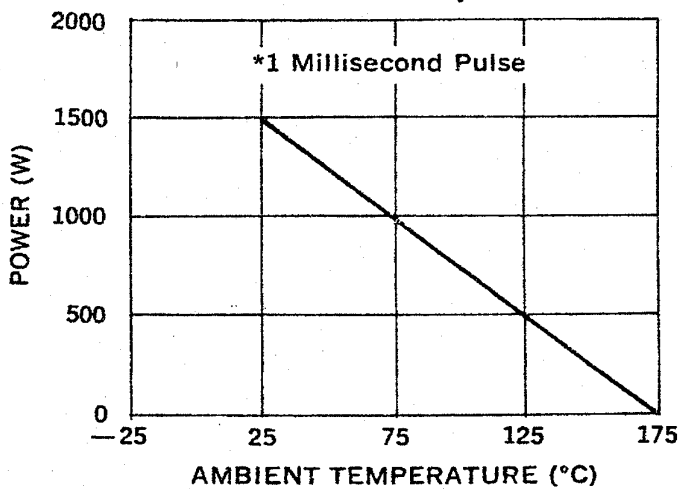

FIGURE 2

1N5610
1N5611
1N5612, 1N5613

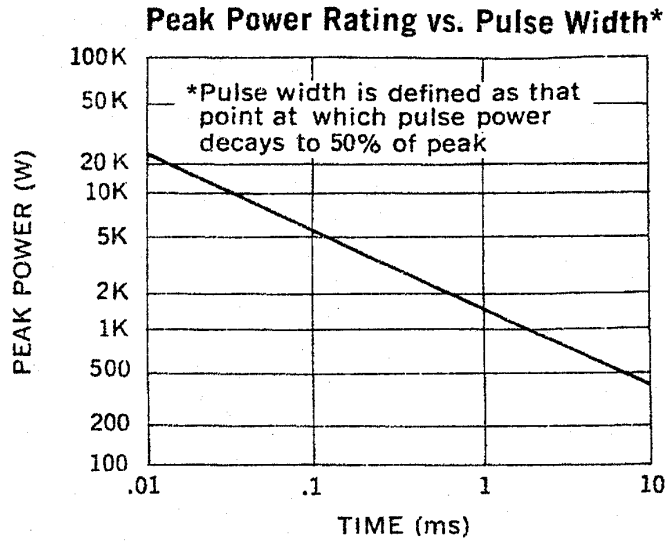

FIGURE 3

Copyright © Each Manufacturing Company.

All Datasheets cannot be modified without permission.

This datasheet has been download from :

www.AllDataSheet.com

100% Free DataSheet Search Site.

Free Download.

No Register.

Fast Search System.

www.AllDataSheet.com