

# NEC

## NPN SILICON TRANSISTOR NE894M13

### FEATURES

- **NEW MINIATURE M13 PACKAGE:**
  - Small transistor outline
  - 1.0 X 0.5 X 0.5 mm
  - Low profile / 0.50 mm package height
  - Flat lead style for better RF performance
- **IDEAL FOR > 3 GHz OSCILLATORS**
- **LOW NOISE, HIGH GAIN**
- **LOW C<sub>re</sub>**
- **UHSO 25 GHz PROCESS**

### DESCRIPTION

The NE894M13 transistor is designed for oscillator applications above 3 GHz. The NE894M13 features low voltage, low current operation, low noise, and high gain. NEC's new low profile/flat lead style "M13" package is ideal for today's portable wireless applications.

### OUTLINE DIMENSIONS (Units in mm)

PACKAGE OUTLINE M13

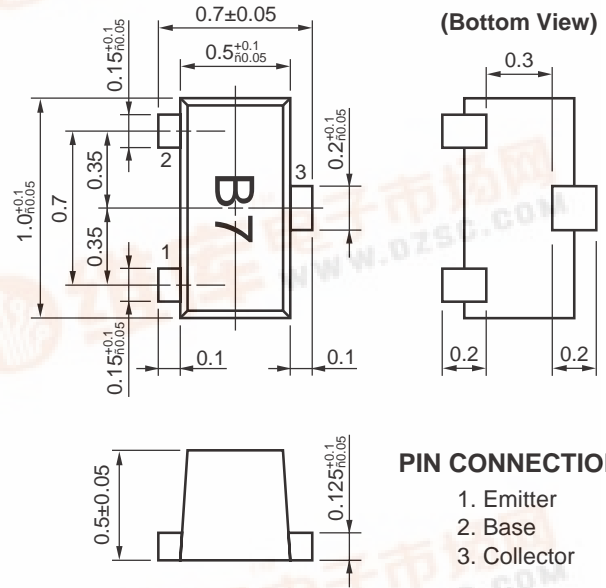

### PIN CONNECTIONS

1. Emitter
2. Base
3. Collector

### ELECTRICAL CHARACTERISTICS (T<sub>A</sub> = 25°C)

PART NUMBER EIAJ <sup>1</sup> REGISTERED NUMBER PACKAGE OUTLINE		NE894M13 2SC5787 M13			
SYMBOLS	PARAMETERS AND CONDITIONS	UNITS	MIN	TYP	MAX
f <sub>T</sub>	Gain Bandwidth at V <sub>CE</sub> = 1 V, I <sub>C</sub> = 20 mA, f = 2 GHz	GHz	17	20	–
S <sub>21E</sub>   <sup>2</sup>	Insertion Power Gain at V <sub>CE</sub> = 1 V, I <sub>C</sub> = 20 mA, f = 2 GHz	dB	11	13	–
NF	Noise Figure at V <sub>CE</sub> = 1 V, I <sub>C</sub> = 5 mA, f = 2 GHz, Z <sub>S</sub> = Z <sub>OPT</sub>	dB	–	1.4	2.5
C <sub>re</sub>	Reverse Transfer Capacitance <sup>3</sup> at V <sub>CB</sub> = 0.5 V, I <sub>E</sub> = 0 mA, f = 1 MHz	pF	–	0.22	0.30
I <sub>CBO</sub>	Collector Cutoff Current at V <sub>CB</sub> = 5 V, I <sub>E</sub> = 0	nA	–	–	100
I <sub>EBO</sub>	Emitter Cutoff Current at V <sub>EB</sub> = 1 V, I <sub>C</sub> = 0	nA	–	–	100
h <sub>FE</sub>	DC Current Gain <sup>2</sup> at V <sub>CE</sub> = 1 V, I <sub>C</sub> = 5 mA		50	–	100

Notes:

1. Electronic Industrial Association of Japan.
2. Pulsed measurement, pulse width ≤ 350 μs, duty cycle ≤ 2 %.
3. Collector to base capacitance when the emitter is grounded

# NE894M13

## ABSOLUTE MAXIMUM RATINGS<sup>1</sup> (T<sub>A</sub> = 25°C)

SYMBOLS	PARAMETERS	UNITS	RATINGS
V <sub>CB0</sub>	Collector to Base Voltage	V	9
V <sub>CEO</sub>	Collector to Emitter Voltage	V	3.0
V <sub>EB0</sub>	Emitter to Base Voltage	V	1.5
I <sub>c</sub>	Collector Current	mA	35
P <sub>T</sub> <sup>2</sup>	Total Power Dissipation	mW	105
T <sub>J</sub>	Junction Temperature	°C	150
T <sub>STG</sub>	Storage Temperature	°C	-65 to +150

Notes:

1. Operation in excess of any one of these parameters may result in permanent damage.
2. With device mounted on 1.08 cm<sup>2</sup> X 1.0 mm glass epoxy board.

## TYPICAL PERFORMANCE CURVES (T<sub>A</sub> = 25°C)

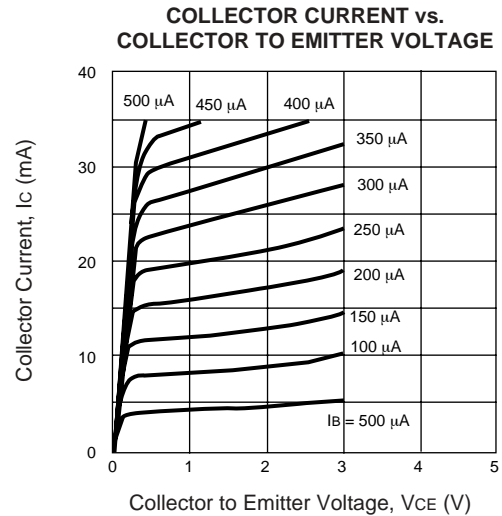
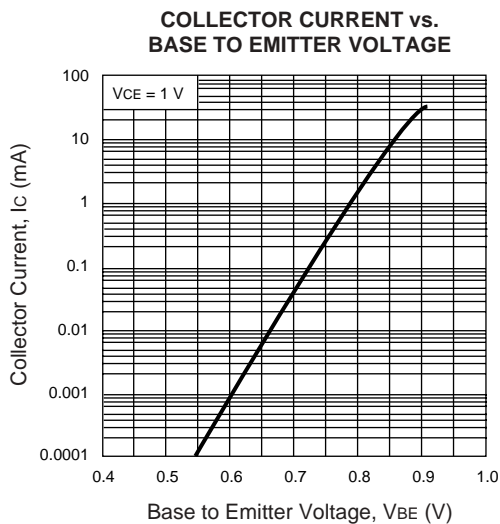
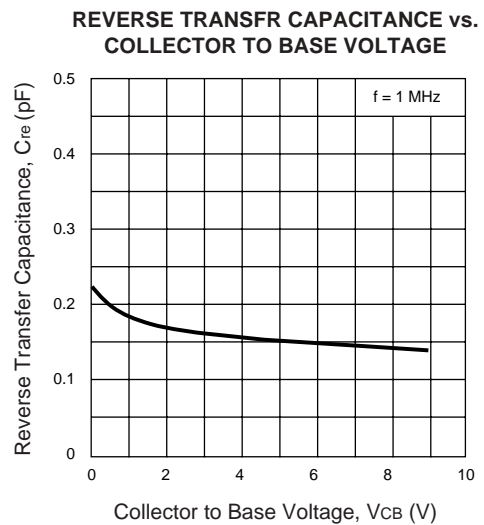
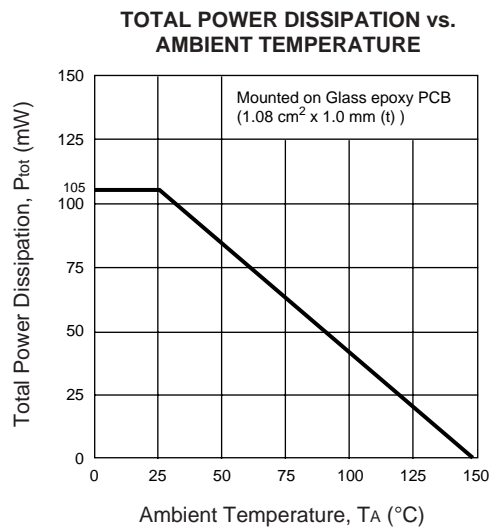

TYPICAL PERFORMANCE CURVES (T<sub>A</sub> = 25°C)

GAIN BANDWIDTH PRODUCT vs. COLLECTOR CURRENT

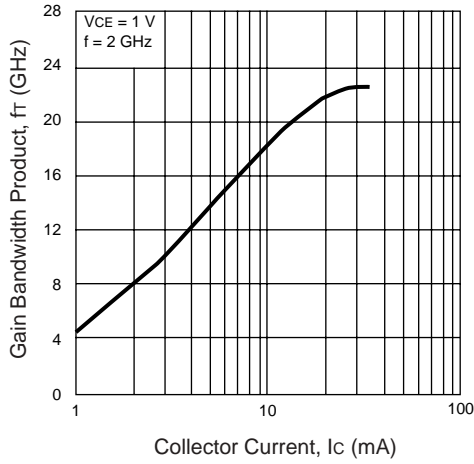

INSERTION POWER GAIN, MAG, MSG vs. FREQUENCY

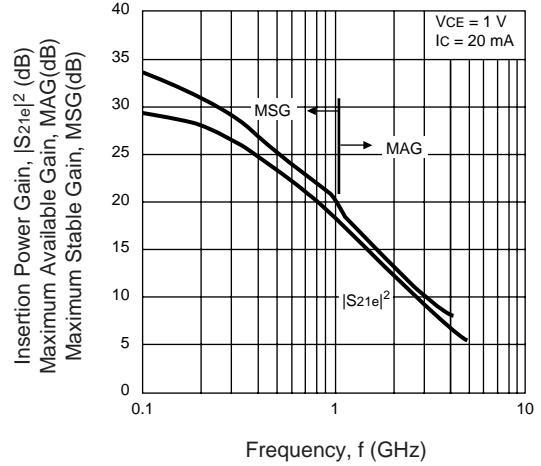

INSERTION POWER GAIN, MAG, MSG vs. COLLECTOR CURRENT

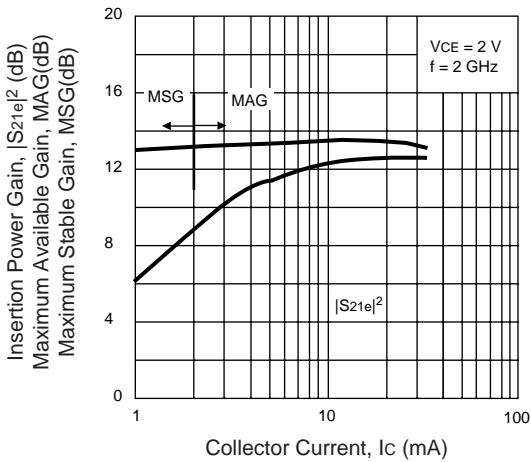

INSERTION POWER GAIN, MAG, MSG vs. COLLECTOR CURRENT

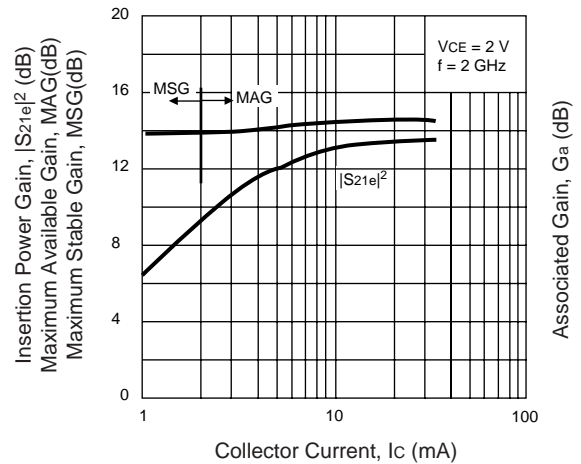

INSERTION POWER GAIN, MAG, MSG vs. COLLECTOR CURRENT

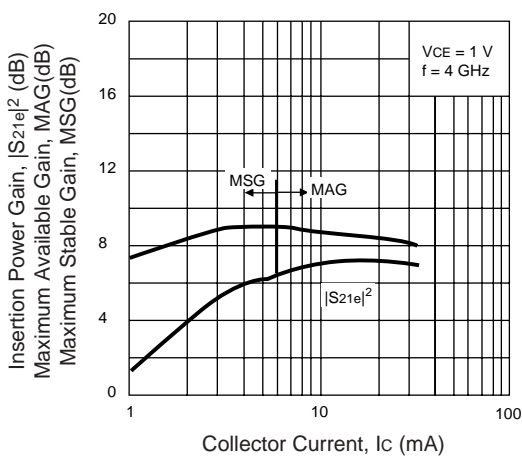

INSERTION POWER GAIN, MAG, MSG vs. COLLECTOR CURRENT

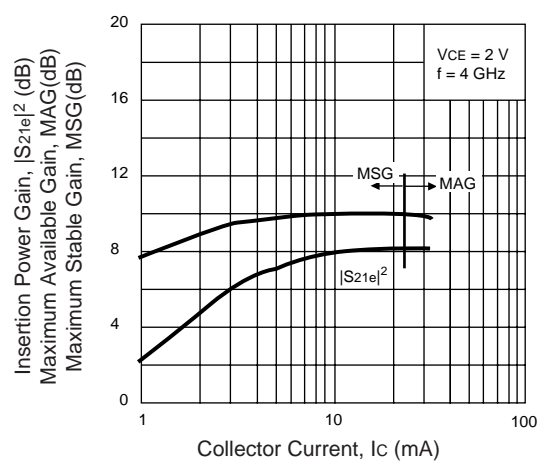

# NE894M13

## TYPICAL PERFORMANCE CURVES (T<sub>A</sub> = 25°C)

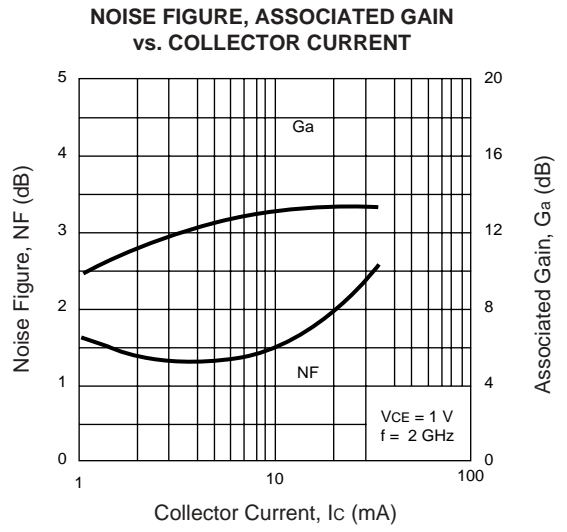
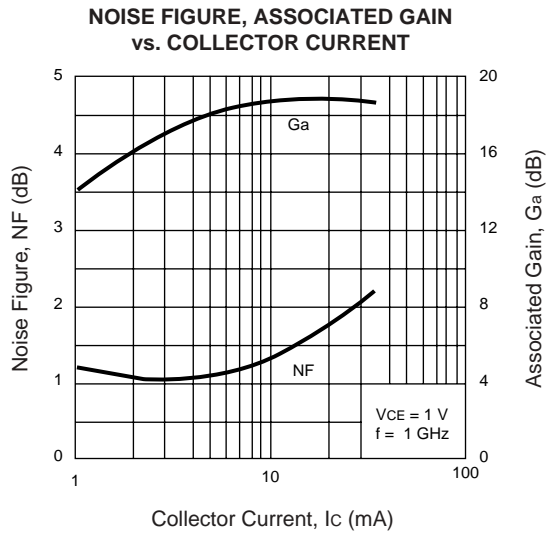

**TYPICAL SCATTERING PARAMETERS** (TA = 25°C)

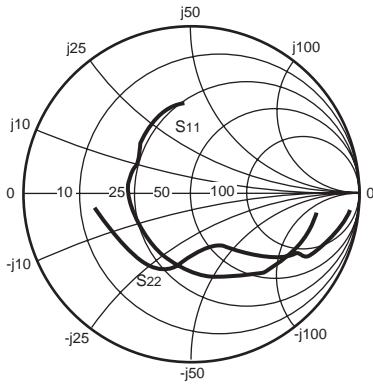

0.100 to 12.000 GHz by 0.050

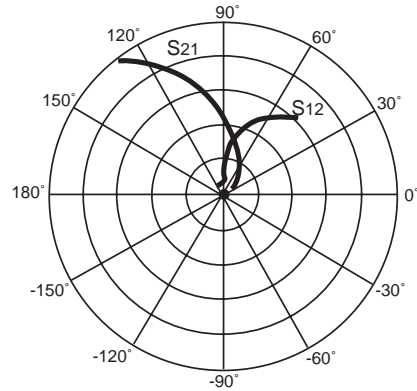

0.100 to 12.000GHz by 0.050

**NE894M13**

Vc = 1 V, Ic = 5 mA

FREQUENCY GHz	S11		S21		S12		S22		K	MAG <sup>1</sup> (dB)
	MAG	ANG	MAG	ANG	MAG	ANG	MAG	ANG		
0.10	0.772	- 11.0	13.002	169.8	0.011	85.6	0.966	- 8.4	0.10	30.55
0.20	0.747	- 24.6	12.548	159.5	0.022	76.8	0.928	- 15.8	0.17	27.54
0.30	0.715	- 36.5	11.948	150.4	0.032	70.6	0.883	- 22.5	0.22	25.75
0.40	0.677	- 47.7	11.241	142.4	0.040	66.2	0.835	- 28.3	0.27	24.50
0.50	0.612	- 59.5	10.457	134.1	0.046	61.3	0.758	- 31.4	0.39	23.57
0.60	0.575	- 68.8	9.699	127.9	0.051	58.2	0.707	- 35.7	0.44	22.79
0.70	0.544	- 76.9	8.993	122.5	0.056	56.5	0.658	- 39.1	0.50	22.09
0.80	0.517	- 84.6	8.364	117.7	0.059	54.9	0.623	- 41.6	0.54	21.50
0.90	0.493	- 91.3	7.756	113.5	0.062	54.1	0.590	- 44.1	0.59	20.94
1.00	0.474	- 97.3	7.228	109.6	0.065	53.6	0.558	- 45.9	0.65	20.46
2.00	0.383	-135.0	4.155	84.4	0.088	58.8	0.411	- 59.5	1.01	16.27
3.00	0.362	-155.9	2.920	68.1	0.120	67.4	0.383	- 73.2	1.10	11.97
4.00	0.355	-175.7	2.253	54.6	0.162	72.0	0.412	- 88.5	1.05	10.08
5.00	0.352	169.2	1.821	44.0	0.215	73.4	0.476	- 98.4	0.95	9.28
6.00	0.339	158.2	1.561	36.0	0.281	72.6	0.512	-103.6	0.86	7.44
7.00	0.359	145.9	1.390	28.0	0.358	68.5	0.522	-114.0	0.81	5.89
8.00	0.394	132.7	1.251	20.9	0.438	62.5	0.523	-127.0	0.79	4.56
9.00	0.432	121.6	1.137	14.9	0.513	55.6	0.521	-142.1	0.80	3.45
10.00	0.466	110.0	1.026	10.5	0.569	48.7	0.543	-157.6	0.84	2.56
11.00	0.489	99.5	0.930	8.9	0.609	43.9	0.572	-165.7	0.87	1.84
12.00	0.489	92.9	0.878	9.3	0.653	40.4	0.567	-168.8	0.90	1.28

Note:

1. Gain Calculations:

$$MAG = \frac{|S_{21}|}{|S_{12}|} \left( K \pm \sqrt{K^2 - 1} \right). \text{ When } K \leq 1, \text{ MAG is undefined and MSG values are used. } MSG = \frac{|S_{21}|}{|S_{12}|}, K = \frac{1 + |\Delta|^2 - |S_{11}|^2 - |S_{22}|^2}{2 |S_{12} S_{21}|}, \Delta = S_{11} S_{22} - S_{21} S_{12}$$

MAG = Maximum Available Gain

MSG = Maximum Stable Gain

# NE894M13

## TYPICAL SCATTERING PARAMETERS (TA = 25°C)

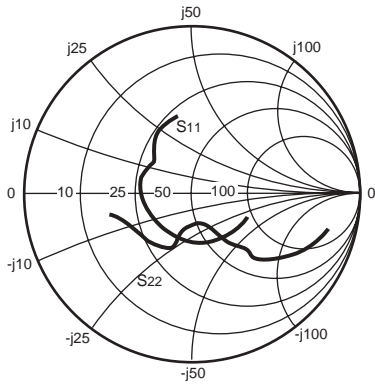

0.100 to 12.000 GHz by 0.050

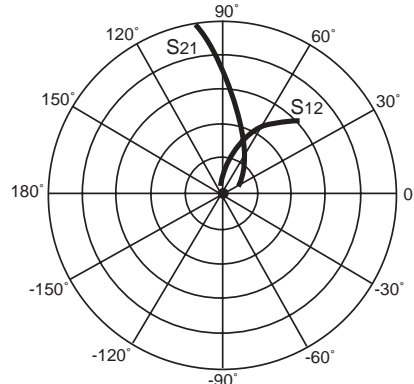

0.100 to 4.000GHz by 0.050

### NE894M13

Vc = 1 V, Ic = 20 mA

FREQUENCY GHz	S11		S21		S12		S22		K	MAG <sup>1</sup> (dB)
	MAG	ANG	MAG	ANG	MAG	ANG	MAG	ANG		
0.10	0.401	-25.4	29.774	160.5	0.009	82.2	0.879	-15.8	0.40	35.10
0.20	0.374	-50.1	26.263	145.4	0.018	74.2	0.786	-28.2	0.45	31.74
0.30	0.345	-69.6	22.629	133.7	0.024	71.0	0.689	-37.3	0.54	29.72
0.40	0.323	-85.0	19.474	124.8	0.029	68.3	0.607	-43.9	0.63	28.21
0.50	0.290	-100.7	16.742	117.7	0.034	67.8	0.506	-46.3	0.75	26.95
0.60	0.282	-111.9	14.691	112.3	0.038	67.6	0.450	-50.3	0.81	25.83
0.70	0.277	-119.6	13.024	108.0	0.043	68.0	0.405	-53.1	0.86	24.84
0.80	0.274	-126.5	11.685	104.4	0.047	68.5	0.374	-54.5	0.90	23.94
0.90	0.273	-132.5	10.574	101.2	0.051	69.0	0.349	-56.2	0.93	23.14
1.00	0.271	-137.0	9.642	98.5	0.056	69.5	0.324	-57.3	0.95	22.37
2.00	0.272	-162.0	5.122	80.3	0.100	72.3	0.228	-66.9	1.06	15.65
3.00	0.275	-176.0	3.539	67.7	0.147	71.6	0.221	-80.0	1.05	12.37
4.00	0.278	167.1	2.723	56.9	0.196	69.5	0.261	-95.5	1.03	10.35
5.00	0.268	153.9	2.223	47.9	0.245	66.9	0.331	-101.9	0.99	9.58
6.00	0.243	146.2	1.922	40.4	0.300	64.6	0.369	-102.7	0.95	8.07
7.00	0.262	138.9	1.720	32.9	0.360	60.8	0.379	-111.1	0.91	6.80
8.00	0.300	129.8	1.565	25.9	0.421	56.4	0.384	-122.9	0.89	5.70
9.00	0.343	122.0	1.439	19.5	0.482	51.5	0.389	-136.9	0.88	4.75
10.00	0.386	112.1	1.316	13.9	0.532	46.5	0.425	-152.2	0.88	3.93
11.00	0.417	102.2	1.199	10.5	0.572	42.8	0.472	-159.8	0.88	3.21
12.00	0.423	96.7	1.123	8.8	0.617	40.2	0.488	-161.6	0.88	2.60

Note:

1. Gain Calculations:

$$MAG = \frac{|S_{21}|}{|S_{12}|} \left( K \pm \sqrt{K^2 - 1} \right). \text{ When } K \leq 1, \text{ MAG is undefined and MSG values are used. } MSG = \frac{|S_{21}|}{|S_{12}|}, K = \frac{1 + |\Delta|^2 - |S_{11}|^2 - |S_{22}|^2}{2 |S_{12} S_{21}|}, \Delta = S_{11} S_{22} - S_{21} S_{12}$$

MAG = Maximum Available Gain

MSG = Maximum Stable Gain

**TYPICAL SCATTERING PARAMETERS** (T<sub>A</sub> = 25°C)

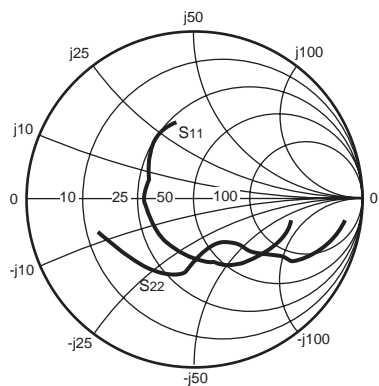

0.100 to 12.000 GHz by 0.050

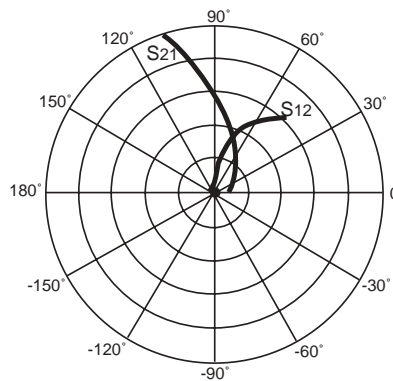

0.100 to 12.000GHz by 0.050

**NE894M13**

V<sub>c</sub> = 2 V, I<sub>c</sub> = 10 mA

FREQUENCY GHz	S <sub>11</sub>		S <sub>21</sub>		S <sub>12</sub>		S <sub>22</sub>		K	MAG <sup>1</sup> (dB)
	MAG	ANG	MAG	ANG	MAG	ANG	MAG	ANG		
0.10	0.634	-14.2	21.168	166.5	0.010	85.7	0.945	-10.0	0.19	33.43
0.20	0.601	-30.0	19.847	154.5	0.017	75.7	0.890	-18.5	0.28	30.64
0.30	0.559	-43.3	18.259	144.2	0.024	70.8	0.826	-25.6	0.36	28.79
0.40	0.515	-55.3	16.598	135.6	0.029	67.6	0.763	-31.2	0.43	27.51
0.50	0.451	-67.4	14.913	127.5	0.034	64.9	0.676	-33.5	0.56	26.40
0.60	0.417	-77.1	13.497	121.5	0.038	63.7	0.621	-37.1	0.62	25.49
0.70	0.391	-84.8	12.240	116.5	0.042	63.5	0.572	-39.6	0.68	24.65
0.80	0.369	-92.2	11.177	112.3	0.045	63.2	0.539	-41.3	0.73	23.93
0.90	0.351	-98.6	10.239	108.5	0.049	63.5	0.510	-42.9	0.78	23.24
1.00	0.337	-104.1	9.431	105.2	0.052	63.9	0.481	-43.9	0.82	22.61
2.00	0.279	-137.6	5.194	83.8	0.084	70.4	0.363	-52.7	1.04	16.74
3.00	0.266	-155.9	3.616	69.6	0.123	74.0	0.345	-64.5	1.05	13.31
4.00	0.262	-175.2	2.787	57.5	0.168	74.7	0.373	-79.7	1.00	11.92
5.00	0.255	170.3	2.259	47.6	0.217	73.9	0.439	-89.6	0.93	10.17
6.00	0.237	161.9	1.936	39.8	0.276	72.7	0.483	-93.7	0.86	8.47
7.00	0.259	151.8	1.731	32.0	0.344	69.3	0.499	-102.7	0.81	7.02
8.00	0.300	139.9	1.571	24.6	0.418	64.4	0.505	-114.4	0.78	5.75
9.00	0.347	129.8	1.439	17.8	0.493	58.5	0.508	-128.5	0.77	4.65
10.00	0.392	117.8	1.303	12.0	0.555	52.3	0.535	-144.5	0.78	3.71
11.00	0.425	106.1	1.170	8.7	0.600	47.5	0.573	-153.9	0.80	2.90
12.00	0.433	99.2	1.080	7.5	0.648	44.1	0.581	-157.6	0.82	2.22

Note:

1. Gain Calculations:

$$MAG = \frac{|S_{21}|}{|S_{12}|} \left( K \pm \sqrt{K^2 - 1} \right). \text{ When } K \leq 1, \text{ MAG is undefined and MSG values are used. } MSG = \frac{|S_{21}|}{|S_{12}|}, K = \frac{1 + |\Delta|^2 - |S_{11}|^2 - |S_{22}|^2}{2 |S_{12} S_{21}|}, \Delta = S_{11} S_{22} - S_{21} S_{12}$$

MAG = Maximum Available Gain

MSG = Maximum Stable Gain

# NE894M13

## NONLINEAR MODEL

### SCHEMATIC

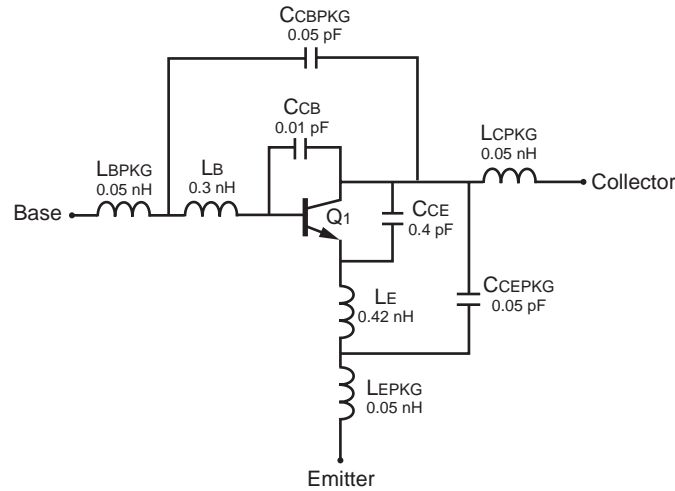

### BJT NONLINEAR MODEL PARAMETERS(1)

Parameters	Q1	Parameters	Q1
IS	137e-18	MJC	0.24
BF	129	XCJC	0.3
NF	0.9992	CJS	0
VAF	22.4	VJS	0.75
IKF	2.8	MJS	0
ISE	229e-15	FC	0.55
NE	2.5	TF	5e-12
BR	81.7	XTF	0.05
NR	0.9944	VTF	0.5
VAR	1.9	ITF	0.005
IKR	0.018	PTF	0
ISC	227e-18	TR	1.0e-9
NC	1.17	EG	1.11
RE	0.75	XTB	0
RB	5	XTI	3
RBM	3	KF	117e-15
IRB	0.005	AF	1.34
RC	6		
CJE	0.68e-12		
VJE	0.92		
MJE	0.26		
CJC	0.16e-12		
VJC	0.64		

(1) Gummel-Poon Model

### ADDITIONAL PARAMETERS

Parameters	NE894M13
CCB	0.01 pF
CCE	0.4 pF
LB	0.3 nH
LE	0.42 nH
CCBPKG	0.05 pF
CCEPKG	0.05 pF
LBX	0.05 nH
LCX	0.05 nH
LEX	0.05 nH

### MODEL TEST CONDITIONS

Frequency: 0.1 to 10 GHz  
 Bias:  $V_{CE} = 0.5 \text{ V to } 2 \text{ V}$ ,  $I_c = 0.5 \text{ mA to } 20 \text{ mA}$   
 Date: 11/2001

#### Life Support Applications

These NEC products are not intended for use in life support devices, appliances, or systems where the malfunction of these products can reasonably be expected to result in personal injury. The customers of CEL using or selling these products for use in such applications do so at their own risk and agree to fully indemnify CEL for all damages resulting from such improper use or sale.