

Features

- Saifun NROM™ NVM Technology
- Operating voltage: 2.7V to 3.6V
- Clock frequency: 100/400/1700/3400 kHz
- Low power consumption
 - 0.5μA standby current typical (L version)
 - <0.2μA standby current typical (LZ version)
- Write Modes
 - Byte Mode
 - Page Mode (128 Bytes/Page)
- Schmitt trigger inputs
- Hardware and software write protection for entire or partial array
- Endurance: up to 1 million data changes
- Data Retention: Greater than 40 years
- Packages: 8-Pin DIP and 8-Pin SOIC and MLF Leadless
- Temperature range
 - Commercial: 0 °C to +70 °C
 - Industrial (E): -40 °C to +85 °C



SA24C1024 Datasheet

1024Kb EEPROM IIC

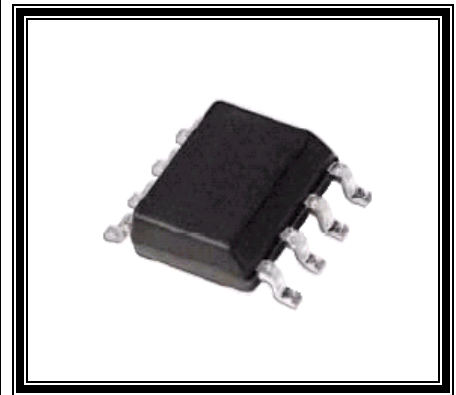

<http://www.saifun.com>

Saifun NROM™ is a trademark of Saifun Semiconductors Ltd.

General Description

The SA24C1024 is a 1024Kbit CMOS non-volatile serial EEPROM organized as 128K x 8 bit memory. This device conforms to Extended IIC 2-wire protocol, which enables accessing of memory in excess of 16 Kbits on an IIC bus. This serial communication protocol uses a Clock signal (SCL) and a Data signal (SDA) to synchronously clock data between a Master (for example, a microcontroller) and a Slave (EEPROM).

The SA24C1024 offers hardware write protection whereby the entire memory array can be write-protected by pulling the WP pin to logic HIGH. The entire memory then becomes unalterable until the WP pin is switched to logic LOW. The device also features programmable write protect with options of full, half or a quadrant of the array.

The LZ version of the SA24C1024 offers very low standby current, which makes it suitable for low power applications. The SA24C1024 is designed to minimize pin count and simplify PC board layout requirements. This device is offered in both SO and DIP packages. A leadless microleadframe package and CSP are under development.

Saifun's EEPROMs are designed and tested for applications requiring high endurance, high reliability and low power consumption.

Table of Contents

Features	1
General Description	2
Block Diagram	4
Connection Diagrams	5
Ordering Information	6
Product Specifications	7
Absolute Maximum Ratings Operating Conditions...	7
ESD/Latch up Specification (JEDEC 8 Spec)	7
Operating Conditions.....	7
V _{CC} (2.7 V to 3.6 V) DC Electrical Characteristics ...	8
Capacitance	8
AC Test Conditions	9
AC Testing Input/Output Waveforms.....	9
AC Characteristics (V _{CC} 2.7 V – 3.6 V).....	9
Bus Timing	10
Write Cycle Timing.....	11
Typical System Configuration	11
Background Information (IIC Bus)	12
Slave Address	12
Device Type	13
Device/Page Block Selection.....	13
Read/Write Bit.....	13
Acknowledge.....	13
Array Address#1.....	13
Array Address#0.....	13
Pin Descriptions	14
Serial Clock (SCL).....	14
Serial Data (SDA).....	14
Write Protect (WP).....	14
Choice 1: Full Array Write Protect	14
Device Selection Input – A1 (as Appropriate)	14
Choice 2: Programmable Write Protect	15
Device Operation	16
Clock and Data Conventions	16
START Condition	16
STOP Condition	16
SA24C1024 Array Addressing.....	16
Write Operations	18
Byte Write	18
Page Write	18
Acknowledge Polling	19
Write Protection	19
Read Operations	20
Current Address Read.....	20
Random Read.....	20
Sequential Read.....	20

Switching from Standard/Fast Modes to High-speed Mode and Back	22
Physical Dimensions	24
Contact Information	27
Life Support Policy	27

List of Figures

Figure 1. SA24C1024 Block Diagram	4
Figure 2. SO Package (MW), Dual Inline (N) – Top View 5	
Figure 3. Leadless Package (MLF) – Top View	5
Figure 4. SA24C1024 Ordering Information.....	6
Figure 5. AC Testing Input/Output Waveforms.....	9
Figure 6. Bus Timing	10
Figure 7. Write Cycle Timing	11
Figure 8. Typical System Configuration	11
Figure 9. Slave Address	12
Figure 10. Data Validity	17
Figure 11. START and STOP Definition	17
Figure 12. Acknowledge Response from Receiver	17
Figure 13. Byte Write	19
Figure 14. Page Write	19
Figure 15. Current Address Read	21
Figure 16. Random Read	21
Figure 17. Sequential Read.....	21
Figure 18. Data Transfer	22
Figure 19. A Complete HS Mode Transfer.....	23
Figure 20. 8-pin Molded Small Outline Package (MW8), Package Number M08D	24
Figure 21. Molded Dual-in-Line Package (N), Package Number N08E.....	25
Figure 22. 8-pin MLF Leadless Package	26

List of Tables

Table 1. Pin Names.....	5
Table 2. Write Protection Truth Table.....	14

Block Diagram

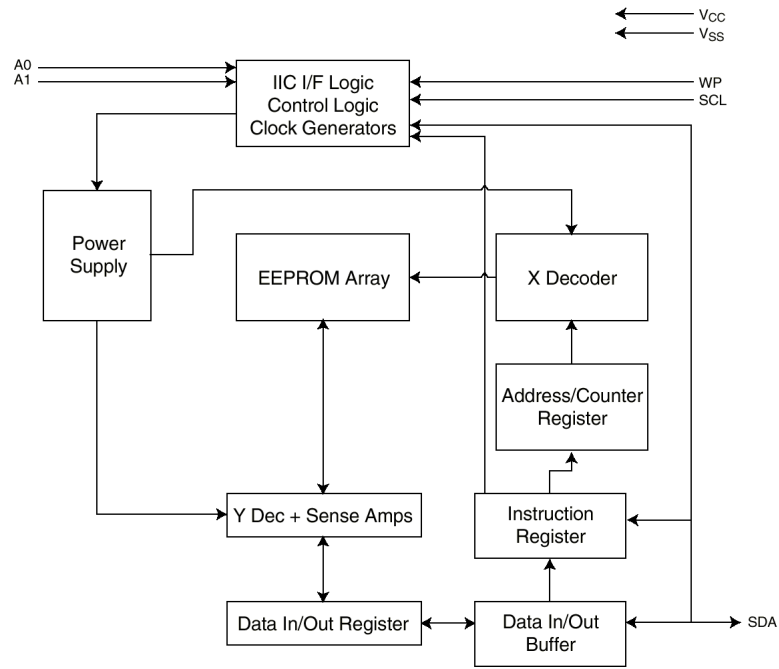

Figure 1. SA24C1024 Block Diagram

Connection Diagrams

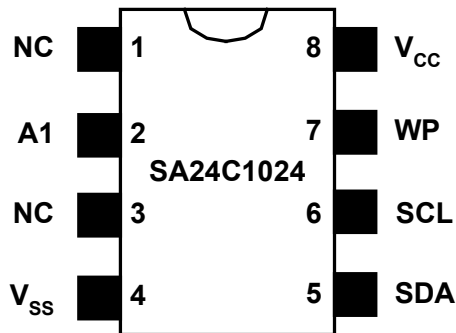

Figure 2. SO Package (MW), Dual Inline (N) – Top View

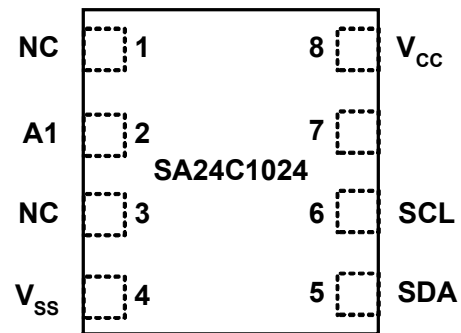

Figure 3. Leadless Package (MLF) – Top View

Note:

For more details, refer to package number N08E and M08D.

Table 1. Pin Names

Symbol	Pin Name	Description
NC	Not Connected	
A1	Device Select Address Input Pin	Has an internal "weak" pulldown, and assumes logic LOW when left unconnected.
NC	Not Connected	
V _{ss}	Device Ground Input Pin	
SDA	IIC Data Input/Output Pin	Open Collector/Drain type.
SCL	IIC Clock Input Pin	
WP	Write Protect	Has an internal "weak" pulldown, and assumes logic LOW when left unconnected. When LOW, writing is allowed to the memory array. When HIGH, writing is not allowed to the memory array, as defined in <i>Write Protect (WP)</i> , page 14.
V _{cc}	Device Power Input Pin	2.7 V to 3.6 V

Note:

No A2 or A0 pins (Pins 2 and 3) are provided, and are instead treated as Not Connected. Internal address comparison assumes pin A2 to be 0, and so the command code should have its corresponding A2 bit set to 0 as well. The command code should also have its corresponding A0 bit set to add16 (MSB address bit).

Ordering Information

<u>SA</u>	<u>24</u>	<u>C</u>	<u>XX</u>	<u>LZ</u>	<u>E</u>	<u>PP</u>	<u>F</u>	<u>X</u>	Letter	Description
								X	Blank X	Tube Tape and Reel
							F		Blank F	Non-lead Free Lead-free Leads
						Package			N MW MF	8-pin DIP 8-pin SOIC (200 mil) 8-lead MLF
					Temp. Range				Blank E	0 to 70°C -40 to +85°C
				Voltage Operating Range					L LZ	2.7 V to 3.6 V 2.7 V to 3.6 V < 0.7 μ A Standby Current
			Density						1024	1 Mb with Write Protect
		Interface							C	CMOS EEPROM Technology
	Interface								24	IIC - 2 Wire
SA									SA	Saifun Non-Volatile Memory

Figure 4. SA24C1024 Ordering Information

Product Specifications

Absolute Maximum Ratings Operating Conditions

Ambient Storage Temperature	-65 °C to +150 °C
All Input or Output Voltages with Respect to Ground	4.5 V to -0.3 V
Lead Temperature (Soldering, 10 seconds)	+300 °C
ESD Rating	2000 V min.

ESD/Latch up Specification (JEDEC 8 Spec)

Human Body Model	Minimum 2 KV
Machine Model	Minimum 500 V
Latch up	100 mA on all pins, +125 °C

Operating Conditions

Ambient Operating Temperature:

- SA24C1024 0°C to +70°C
- SA24C1024E -40°C to +85°C

Positive Power Supply:

- SA24C1024 2.7 V to 3.6 V
- SA24C1024LZ 2.7 V to 3.6 V

V_{CC} (2.7 V to 3.6 V) DC Electrical Characteristics

Symbol	Parameter	Test Conditions	Limits			Units
			Min	Typ (Notes)	Max	
I _{CCA}	Active Power Supply Current	f _{SCL} = 100 kHz (Read)		2	3	mA
		f _{SCL} = 100 kHz (Write)		8	11	mA
		f _{SCL} = 400 KHZ (Read)		2	3	mA
		f _{SCL} = 400 kHz (Write)		8	11	mA
		f _{SCL} = 1.7 MHz (Read)		5	7	mA
		f _{SCL} = 1.7 MHz (Write)		8	11	mA
		f _{SCL} = 3.4 MHz (Read)		5	7	mA
		f _{SCL} = 3.4 MHz (Write)		8	11	mA
I _{SB}	Standby Current (L)	V _{IN} = GND or V _{CC}		0.5	1	μA
	Standby Current (LZ)	V _{IN} = GND or V _{CC}		0.2	0.7	μA
I _{IL}	Input Leakage Current	V _{IN} = GND to V _{CC}		0.1	1	μA
I _{OL}	Output Leakage Current	V _{OUT} = GND to V _{CC}		0.1	1	μA
V _{IL}	Input Low Voltage		-0.3		V _{CC} x 0.3	V
V _{IH}	Input High Voltage		V _{CC} * 0.7		V _{CC} + 0.5	V
V _{OL}	Output Low Voltage	I _{OL} = 3 mA			0.4	V

Notes:

- (1) Typical values are T_A = +25 °C and nominal supply voltage of 3 V.
- (2) Write frequency is 50 Hz.

Capacitance

T_A = +25 °C, f = 100/400 kHz/1.7 MHz/3.4 MHz, V_{CC} = 3V (see note 2)

Symbol	Test	Conditions	Max	Units
C _{I/O}	Input/Output Capacitance (SDA)	V _{I/O} = 0 V	8	pF
C _{IN}	Input Capacitance (A0, A1, A2, SCL)	V _{IN} = 0 V	6	pF

Notes:

- (1) This parameter is periodically sampled and not 100% tested.
- (2) Typical values are T_A = +25 °C and nominal supply voltage of 3 V.

AC Test Conditions

Input Pulse Levels	$V_{CC} * 0.1$ to $V_{CC} * 0.9$
Input Rise and Fall Times	10 ns
Input & Output Timing Levels	$V_{CC} * 0.3$ to $V_{CC} * 0.7$
Output Load	1 TTL Gate and $CL = 100$ pF

AC Testing Input/Output Waveforms

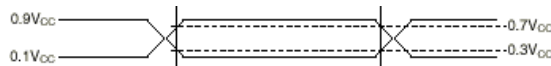

Figure 5. AC Testing Input/Output Waveforms

AC Characteristics ($V_{CC} 2.7 V - 3.6 V$)

Symbol	Parameter	100 kHz		400 kHz		1.7 MHz		3.4 MHz		Units
		Min	Max	Min	Max	Min	Max	Min	Max	
f_{SCL}	SCL Clock Frequency		100		400		1700		3400	kHz
t_{LOW}	Clock Low Period	4700		1300		320		160		ns
t_{HIGH}	Clock High Period	4000		600		120		60		ns
$t_{SU:STA}$	Start Condition Setup Time (for a repeated START condition)	4700		600		160		160		ns
$t_{HD:STA}$	Start Condition Hold Time (for a repeated START condition)	4000		600		160		160		ns
$t_{SU:STO}$	Stop Condition Setup Time	4000		600		160		160		ns
t_{RDA}	SDA Rise Time (depend on external pullup)		1000		300	20	170	10	85	ns
t_{FDA}	SDA Fall Time		300		300	20	170	10	85	ns
t_{RCL}	SCL Rise Time (depend on external pullup)		1000		300	20	80	10	40	ns
t_{FCL}	SCL Fall Time		300		300	20	80	10	40	ns

Symbol	Parameter	100 kHz		400 kHz		1.7 MHz		3.4 MHz		Units
		Min	Max	Min	Max	Min	Max	Min	Max	
t_{RCL1}	SCL Rise Time (after repeated START or after ACK bit)		N/A	N/A	N/A	20	160	10	80	ns
$t_{SU:DAT}$	Data In Setup Time	250		100		20		20		ns
$t_{HD:DAT}$	Data In Hold Time	0		0		0		0		ns
t_{DH}	Data Out Hold Time	200		100		0		0		ns
T_I	Noise Suppression Time Constant at SCL, SDA Inputs (minimum V_{IN} pulse width)		50		50		10		10	ns
t_{AA}	SCL Low to SDA Data Out Valid	300 ¹	3500	100 ¹	900	0	170	0	85	ns
t_{BUF}	Time the Bus Must Be Free Before a New Transmission Can Start	4700		1300		320		160		ns
t_{WR}	Write Cycle Time		10		10		10		10	ms
	Endurance	1 Million ²								Cycles

¹ The minimum value is defined in order to bridge the undefined part between V_{IH} and V_{IL} of the falling edge of SCL. The standard value is 0 ns.

² This parameter is not tested but ensured by characterization.

Bus Timing

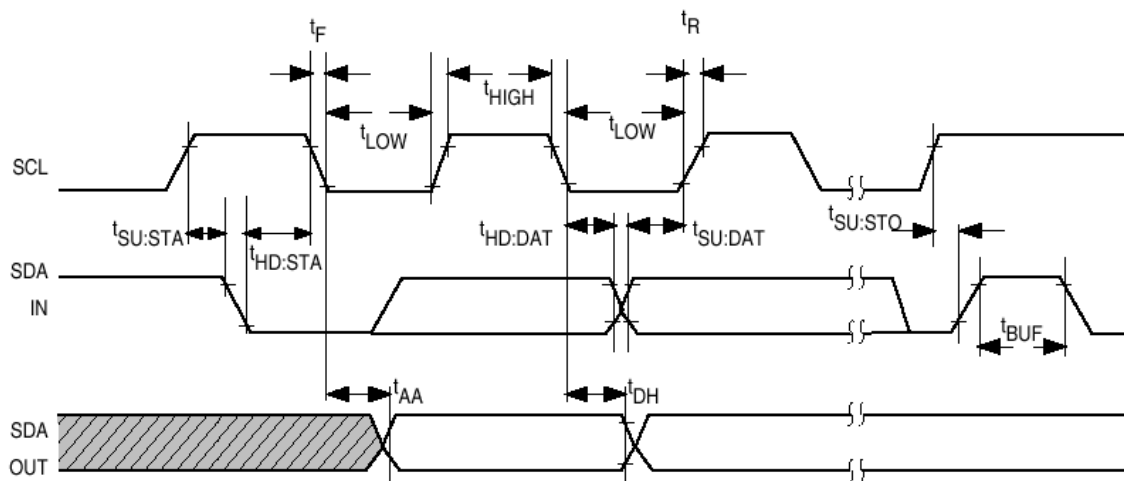

Figure 6. Bus Timing

Write Cycle Timing

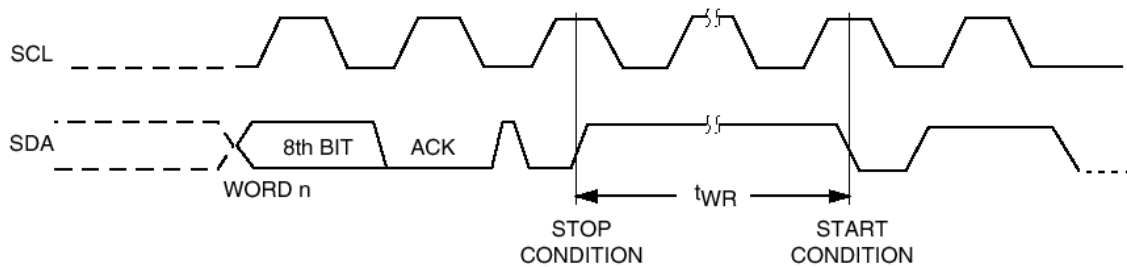

Figure 7. Write Cycle Timing

Note:

The write cycle time (t_{WR}) is the time from a valid STOP condition of a Write sequence to the end of the internal erase/program cycle.

Typical System Configuration

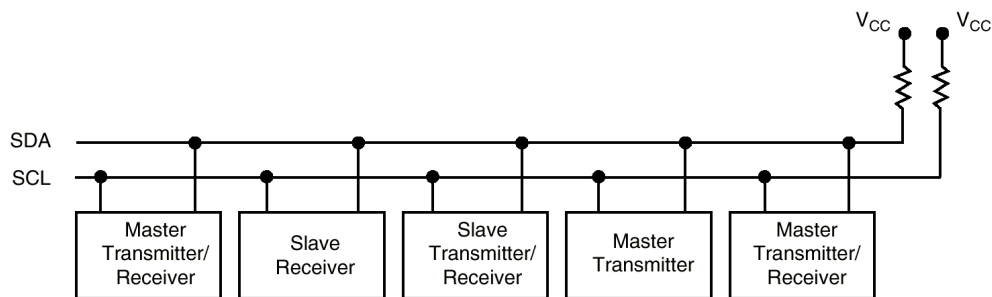

Figure 8. Typical System Configuration

Note:

Due to the open drain configuration of SDA and SCL, a bus-level pullup resistor is called for (typical value = 4.7 k Ω).

Background Information (IIC Bus)

Extended IIC specification is an extension of the Standard IIC specification, which enables addressing of EEPROMs with more than 15 Kbits of memory on an IIC bus. The difference between the two specifications is that the Extended IIC specification defines two bytes of Array Address information, while the Standard IIC specification defines only one. All other aspects are identical between the two specifications. Using two bytes of the array address, one Device/Page Block selection bit (A1) in the Slave address byte and one address signal (add16) in the Slave address, it is possible to address up to 2 Mbits ($2^8 \cdot 2^8 \cdot 2 \cdot 2 \cdot 8 = 2$ Mbits) of memory on an IIC bus.

Note that, due to format difference, it is not possible to have both peripherals that follow the Standard IIC specification (for example, 16Kbit EEPROM) and peripherals that follow the Extended IIC specification (for example, 1024Kbit EEPROM) on a common IIC bus.

The IIC bus allows synchronous bidirectional communication between a transmitter and a receiver using a Clock signal (SCL) and a Data signal (SDA). Additionally, there is one Address signal (A1) that collectively serves as "chip select signal" to a device (for example, EEPROM) on the bus.

All communication on the IIC bus must be started with a valid START condition (by the Master), followed by transmittal (also by the Master) of byte(s) of information (Address/Data). For every byte of information received, the addressed receiver provides a valid acknowledge (ACK) pulse to further continue the communication (unless the receiver intends to discontinue the communication). Depending on the direction of transfer (Write or Read), the receiver can either be a Slave or the Master. A typical IIC communication concludes with a STOP condition by the Master.

Addressing an EEPROM memory location involves sending a command string with the following information:

[DEVICE TYPE]—[DEVICE/PAGE BLOCK SELECTION (including ARRAY MSB ADDRESS BIT (add16))]—[R/WBIT]—[ARRAY ADDRESS Byte #1]—[ARRAY ADDRESS Byte #0]

Slave Address

The Slave address is an 8-bit information consisting of a Device Type field (4 bits), a Device/Page Block selection field (3 bits) and one Read/Write bit.

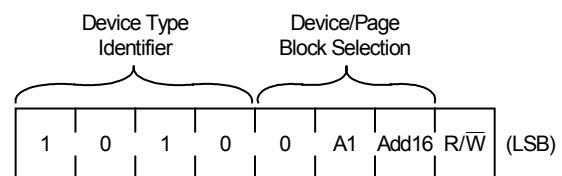

Figure 9. Slave Address

Device Type

The IIC bus is designed to support a variety of devices, such as RAMs, EPROMs, and so on, as well as EEPROMS. In order to properly identify the various devices on the IIC bus, a 4-bit Device Type identifier string is used. For EEPROMS, this 4-bit string is 1-0-1-0. Every IIC device on the bus internally compares this 4-bit string to its own Device Type string to ensure proper device selection.

Device/Page Block Selection

When multiple devices of the same type (for example, multiple EEPROMS) are present on the IIC bus, the A1 address information bit is used in device selection. Every IIC device on the bus internally compares the first 2 bits of the Device/Page Block selection string to its own physical configuration (0, A1pin – for the SA24C1024, the Device/Page Block selection MSB is always 0) to ensure proper device selection. This comparison is carried out in addition to the Device Type comparison.

In addition to selecting an EEPROM, the second and third Device/Page Block selection bits (A1, add16) can be viewed as selection controls to a page block within the selected EEPROM. Each page block is 512 Kbits (64 KBytes) in size.

Read/Write Bit

The last bit of the Slave address indicates whether the intended access is Read or Write. If the bit is 1, the access is Read; if it is 0, the access is Write.

Acknowledge

Acknowledge is an active LOW pulse on the SDA line that is driven by an addressed receiver to the addressing transmitter to indicate receipt of 8 bits of data. The receiver provides an ACK pulse for every 8 bits of data received. This handshake mechanism is done as follows:

1. After transmitting 8 bits of data, the transmitter releases the SDA line and waits for the ACK pulse.
2. The addressed receiver, if present, then drives the ACK pulse on the SDA line during the 9th clock and releases the SDA line back to the transmitter.

For more details, see Figure 12.

Array Address#1

This is an 8-bit information that contains the most significant 8 bits (without the MSB bit, which is the add16 bit located in the Slave address byte) of the 17-bit memory array address.

Array Address#0

This is an 8-bit information that contains the least significant 8 bits of the 17-bit memory array address.

Pin Descriptions

Serial Clock (SCL)

The SCL input is used to clock all data into and out of the device.

Serial Data (SDA)

SDA is a bidirectional pin used to transfer data into and out of the device. It is an open drain output and may be wire-ORed with any number of open drain or open collector outputs.

Write Protect (WP)

Choice 1: Full Array Write Protect

If pulled HIGH, Write operations are not executed, and Read operations are possible. If pulled LOW, normal operation is enabled, and Read/Write over the entire memory is possible.

This feature allows the user to assign the entire memory as ROM, which can then be protected against accidental programming. When Write is disabled, the Slave address and word address are acknowledged but data is not.

This pin has an internal pulldown circuit. However, on systems where write protection is not required, it is recommended that this pin be tied to V_{SS} .

Table 2. Write Protection Truth Table

WP Pin	"Less Than" Comparison	T/B Bit	Write Allowed
1	YES	0	NO
1	NO	0	YES
1	YES	1	YES
1	NO	1	NO
0	Don't Care	Don't Care	YES

Device Selection Input – A1 (as Appropriate)

This input serves as a chip select signal to an EEPROM when multiple EEPROMs are present on the same IIC bus. These inputs, if present, should be connected to V_{CC} or V_{SS} in a unique manner to enable proper selection of an EEPROM among multiple EEPROMs.

During a typical addressing sequence, every EEPROM on the IIC bus compares the configuration of these inputs to the respective two MSBs of the Device/Page Block selection information (which is part of the Slave address) to determine a valid selection. For example, if the two MSB bits of the Device/Page Block selection are 0-0, the EEPROM whose Device Selection input (A1) is connected to the respective V_{SS} is selected.

On the SA24C1024, only A1 is provided, so the corresponding A2 bit in the Device/Page Block selection should be set to 0 during all accesses to the device. These two pins have a weak internal pulldown circuit.

Choice 2: Programmable Write Protect ⁽¹⁾

The Programmable Write protection is available to customers by contacting a Sales Representative. For this option, use an internal 8-bit wide internal NV-Latch with the following definition:

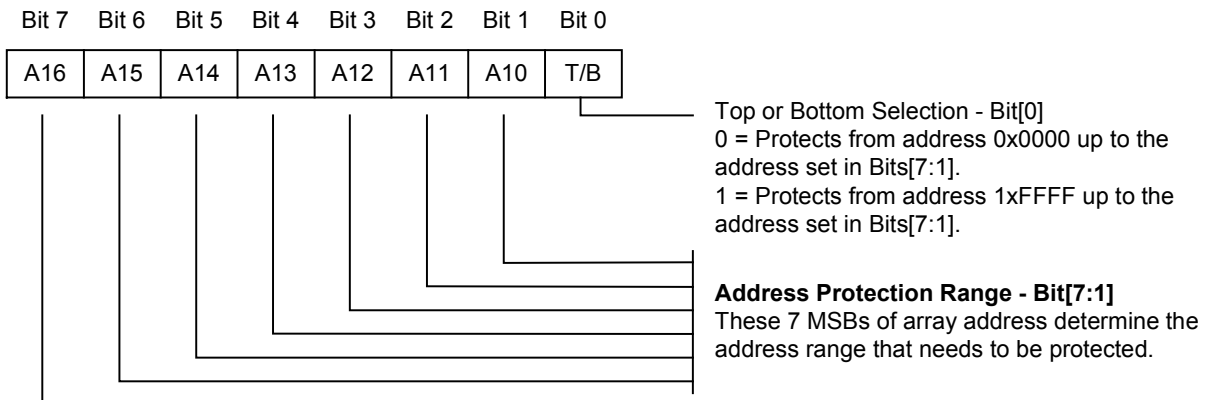

¹ Predefined on Sort. Not a user command.

Example (1024K)	Write Protection Area	NV-Latch Bit Setting - Bits [7:0]	Result
1	Full Array (0x0000 – 0x1FFFF)	0-0-0-0-0-0-0-1	Address bits (A16:A10) issued during the Write command are compared against bits[7:1] of this NV-Latch. As bit[0] of this NV-Latch is set to 1, Write is not allowed as long as the comparison results in a greater than or equal to status.
2	Bottom Half (0x0000 – 0x0FFFF)	1-0-0-0-0-0-0-0	As in example 1.
3	Bottom Quadrant (0x0000 – 0x07FFF)	0-1-0-0-0-0-0-0	As in example 1.
4	Top Quadrant (0x18000 – 0x1FFFF)	1-1-0-0-0-0-0-1	Address bits (A16:A10) issued during the Write command are compared against bits[7:1] of this NV-Latch. As bit[0] of this NV-Latch is set to 1, Write is allowed as long as the comparison results in a greater than or equal to status.
5	Top Half (0x10000 – 0x1FFFF)	1-0-0-0-0-0-0-1	As in example 4.
6	No Write Protection	0-0-0-0-0-0-0-0	As in example 4.

Device Operation

The SA24C1024 supports a bidirectional bus-oriented protocol, which defines any device that sends data onto the bus as a transmitter and the receiving device as the receiver. The device controlling the transfer is defined as the Master and the device that is controlled is the Slave. The Master always initiates data transfers and provides the clock for both transmit and receive operations. The SA24C1024 is therefore considered to be the Slave in all applications.

Clock and Data Conventions

Data states on the SDA line can change only during SCL LOW. SDA state changes during SCL HIGH are reserved for indicating START and STOP conditions. For more details, see Figure 10.

START Condition

All commands are preceded by the START condition, which is a HIGH-to-LOW transition of SDA when SCL is HIGH. The SA24C1024 continuously monitors the SDA and SCL lines for the START condition and does not respond to any command until this condition has been met. For more details, see Figure 11.

STOP Condition

All communications are terminated by a STOP condition, which is a LOW-to-HIGH transition of SDA when SCL is HIGH. The STOP condition is also used by the SA24C1024 to place the device in the standby power mode. For more details, see Figure 11.

SA24C1024 Array Addressing

During Read/Write operations, addressing the EEPROM memory array involves providing the Slave address with the Most Significant Address bit (add16), as well as two address bytes, Word Address 1 and Word Address 0. The Word Address 1 byte contains the 8 MSBs of the array address, while the Word Address 0 byte contains the 8 LSBs of the array address.

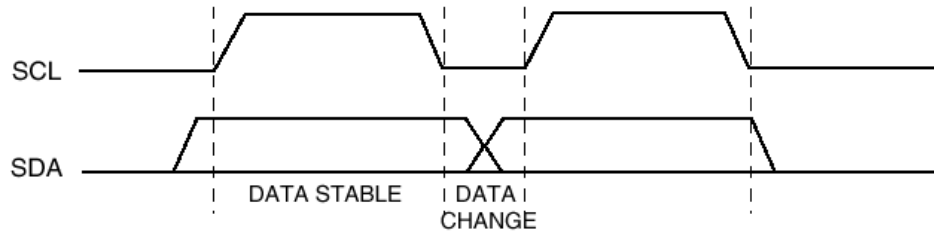

Figure 10. Data Validity

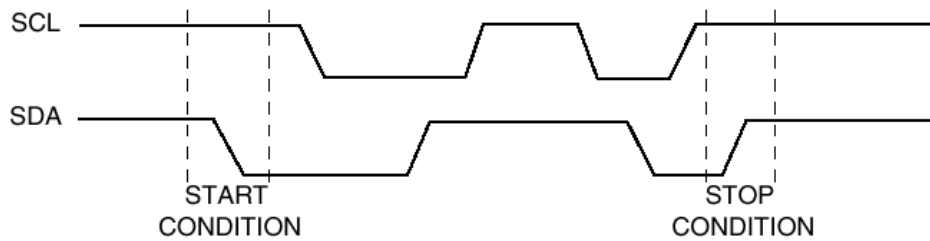

Figure 11. START and STOP Definition

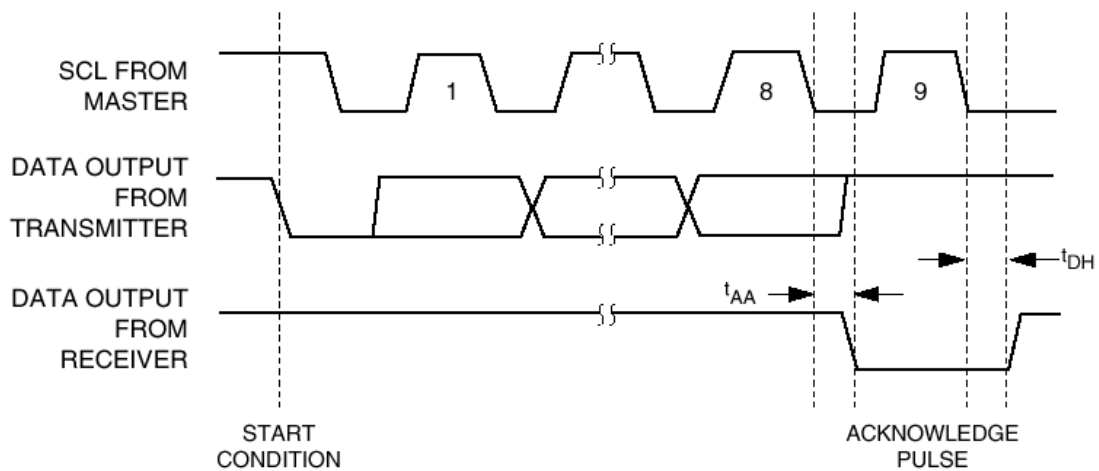

Figure 12. Acknowledge Response from Receiver

Write Operations

Byte Write

Two address bytes are required after the Slave address, which contains the Most Significant Address bit (add16), for a byte Write operation. These 17 address bits select one out of the 128K locations in the memory. The Master provides these address bytes, and for each address byte received, the SA24C1024 responds with an ACK pulse. The Master then provides a byte of data to be written into the memory. Upon receipt of this data, the SA24C1024 again responds with an ACK pulse. The Master then terminates the transfer by generating a STOP condition, at which time the SA24C1024 begins the internal write cycle to the memory. While the internal write cycle is in progress, the SA24C1024 inputs are disabled, and the device does not respond to any requests from the Master for the duration of t_{WR} . For more details regarding the address, acknowledge and data transfer sequence, see Figure 13.

Page Write

To minimize write cycle time, the SA24C1024 offers a Page Write feature, which allows simultaneous programming of up to 128 contiguous bytes. To facilitate this feature, the memory array is organized in terms of "pages." A page consists of 128 contiguous byte locations starting at every 128-byte address boundary (for example, starting at array address 0x00000, 0x00080, 0x00100, and so on).

The Page Write operation is confined to a single page, which means that it does not cross over to locations on the next page but rolls over to the beginning of the page whenever the end of the page is reached and additional data bytes continue to be provided. A Page Write operation can be initiated to begin at any location within a page (the starting address of the Page Write operation does not have to be the starting address of a page).

Page Write is initiated in the same manner as the Byte Write operation; however, rather than terminate the cycle after transmitting the first data byte, the Master can further transmit up to 127 more bytes. After the receipt of each byte, the SA24C1024 responds with an ACK pulse, increments the internal address counter to the next address, and is ready to accept the next data. If the Master transmits more than 128 bytes prior to generating the STOP condition, the address counter rolls over and previously loaded data is re-loaded. As with the Byte Write operation, all inputs are disabled until completion of the internal write cycle. For more details regarding the address, acknowledge, and data transfer sequence, see Figure 14.

Acknowledge Polling

Once the STOP condition is issued to indicate the end of the host's Write operation, the SA24C1024 initiates the internal write cycle. ACK polling can be initiated immediately, which involves issuing the START condition followed by the Slave address for a Write operation.

If the SA24C1024 is still busy with the Write operation, no ACK is returned. If the SA24C1024 has completed the Write operation, an ACK is returned and the host can then proceed with the next Read or Write operation.

Write Protection

Programming of the memory does not take place if the SA24C1024's WP pin is pulled HIGH. The SA24C1024 responds to Slave and byte addresses but does not generate an ACK after the first byte of data has been received. This means that the program cycle is not started when the STOP condition is asserted.

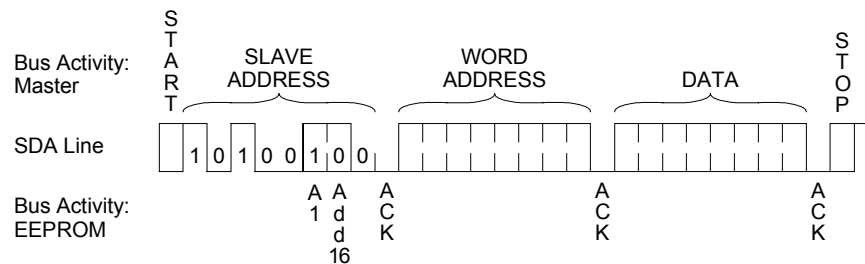

Figure 13. Byte Write

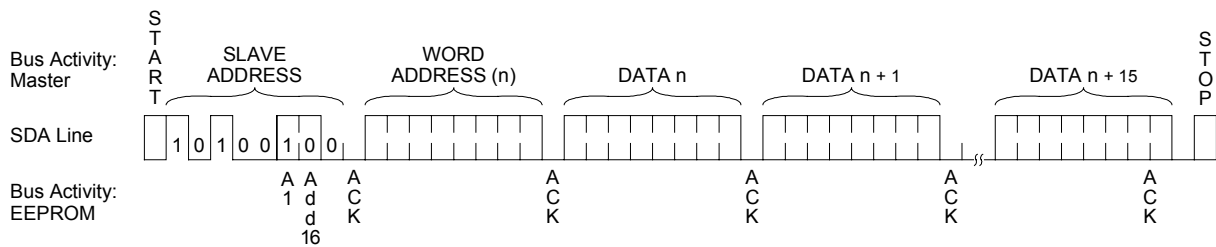

Figure 14. Page Write

Read Operations

Read operations are initiated in the same manner as Write operations, with the exception that the $\overline{R/W}$ bit of the Slave address is set to 1. There are three basic Read operations: current address Read, random Read, and sequential Read.

Current Address Read

Internally the SA24C1024 contains an address counter that maintains the address of the last byte accessed, incremented by 1. Therefore, if the last access (either a Read or Write) was to address n , the next Read operation would access data from address $n + 1$. Upon receipt of the Slave address with $\overline{R/W}$ set to 1, the SA24C1024 issues an ACK pulse and transmits the 8-bit word. The Master does not acknowledge the transfer but does generate a STOP condition, which causes the SA24C1024 to discontinue transmission. For more details regarding the sequence of address, acknowledge and data transfer, see Figure 15.

Random Read

Random Read operations enable the Master to access any memory location in a random manner. Prior to issuing the Slave address with the $\overline{R/W}$ bit set to 1, the Master must first perform a “dummy” Write operation. The Master issues the START condition, the Slave address's $\overline{R/W}$ bit is set to 0 and the byte address is read. After the byte address is acknowledged, the Master immediately issues another START condition and the Slave address's $\overline{R/W}$ bit is set to 1. This is followed by an ACK from the SA24C1024 and then by the 8-bit word. The Master does not acknowledge the transfer but does generate the STOP condition, which causes the SA24C1024 to discontinue transmission. For more details regarding address, acknowledge, and data transfer sequence, see Figure 16.

Sequential Read

Sequential Reads can be initiated as either a current address Read or random access Read. The first word is transmitted in the same manner as the other Read modes; however, the Master responds with an ACK pulse, indicating it requires additional data. The SA24C1024 continues to output data for each ACK received. The Read operation is terminated either by the Master not responding with an ACK pulse or by generating a STOP condition.

The data output is sequential, with the data from address n followed by the data from $n + 1$. The address counter for Read operations increments all word address bits, enabling the entire memory contents to be serially read during one operation. After the entire memory has been read, the

counter rolls over to the beginning of the memory. The SA24C1024 continues to output data for each ACK received. For details regarding the address, acknowledge, and data transfer sequence, see Figure 17.

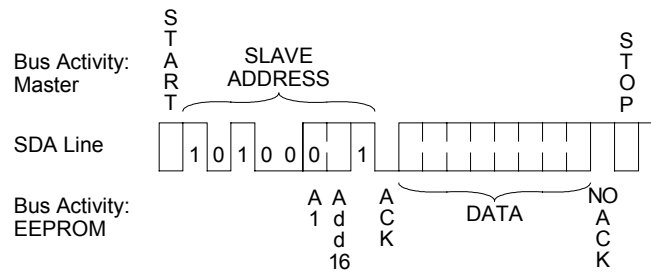

Figure 15. Current Address Read

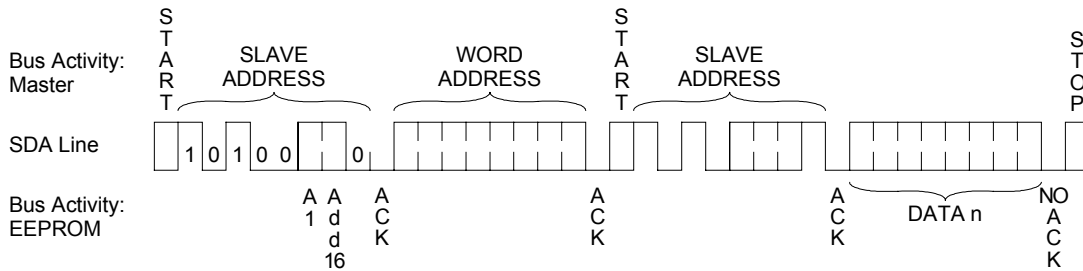

Figure 16. Random Read

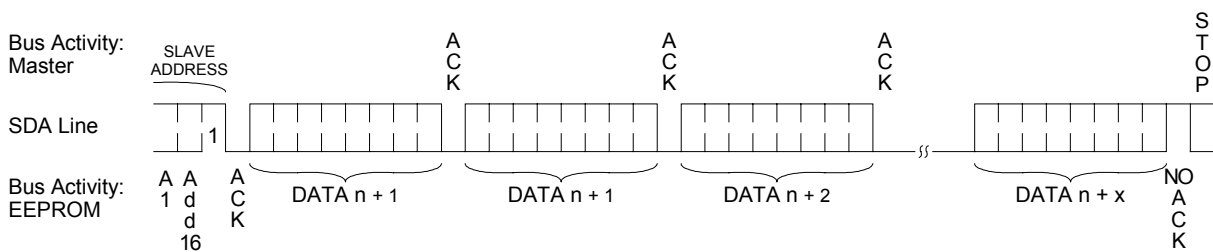

Figure 17. Sequential Read

Switching from Standard/Fast Modes to High-speed Mode and Back

The Standard (S), Fast (F) and High-speed (HS) modes are defined according to the IIC Bus specifications as follows:

- **S mode:** Maximum bit transfer rates of 100 Kbps.
- **F mode:** Maximum bit transfer rates of 400 Kbps.
- **HS mode:** Maximum bit transfer rates of 3.4 Mbps.

After reset and initialization, the device must be put in F mode. The Master on the bus can then choose to switch the connected Slave devices to HS mode. The Slave device must recognize the "S 00001XXX A" sequence and then must switch its internal circuit from F mode to HS mode. Each device must also recognize the STOP condition and switch back to F mode.

Timings and flow can be seen in Figure 18 and Figure 19.

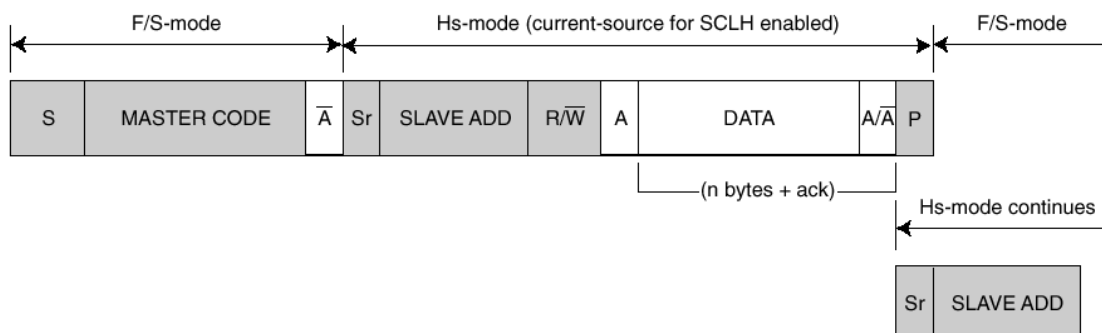

Figure 18. Data Transfer

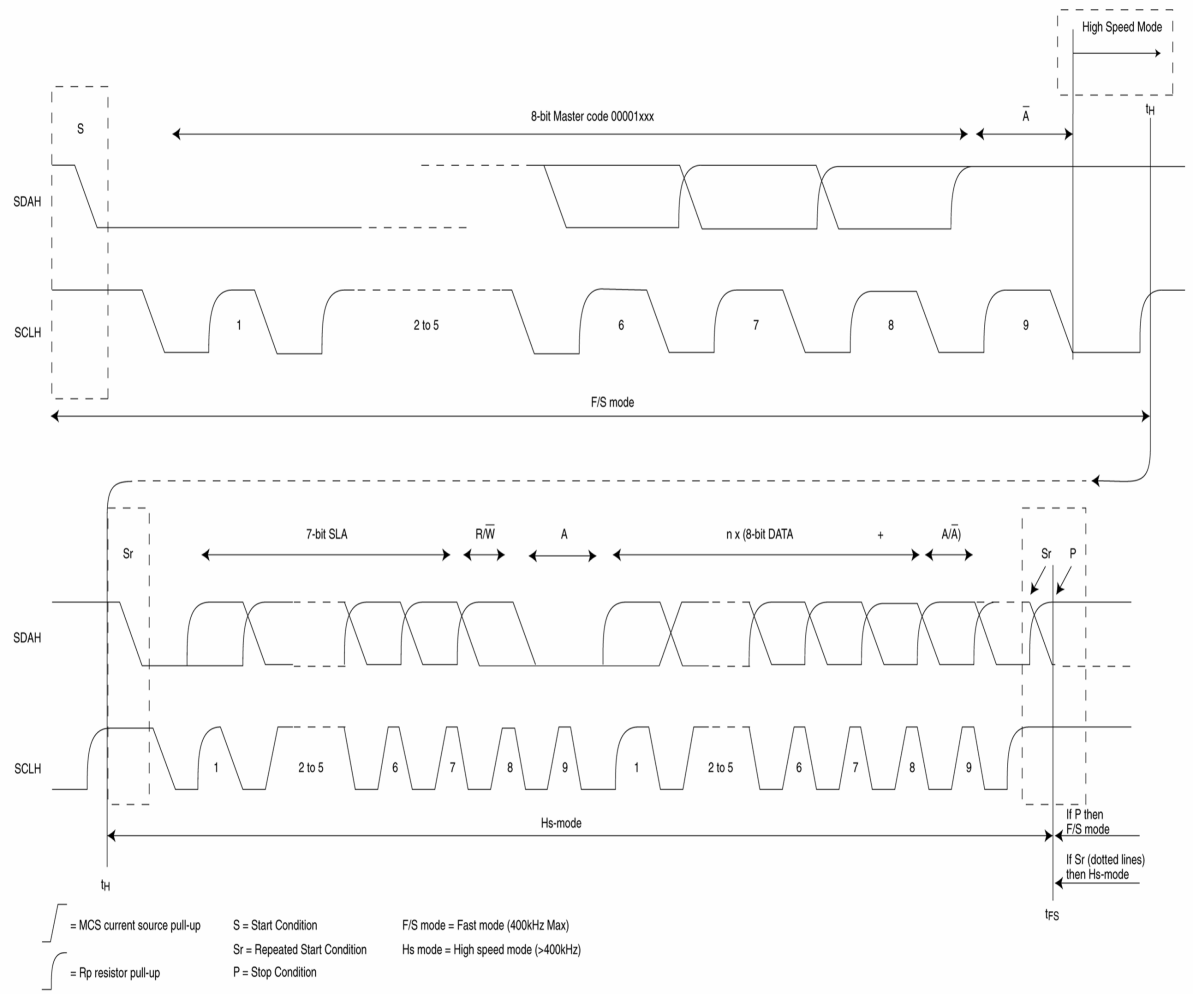

Figure 19. A Complete HS Mode Transfer

Physical Dimensions

All measurements are in inches (millimeters), unless otherwise specified.

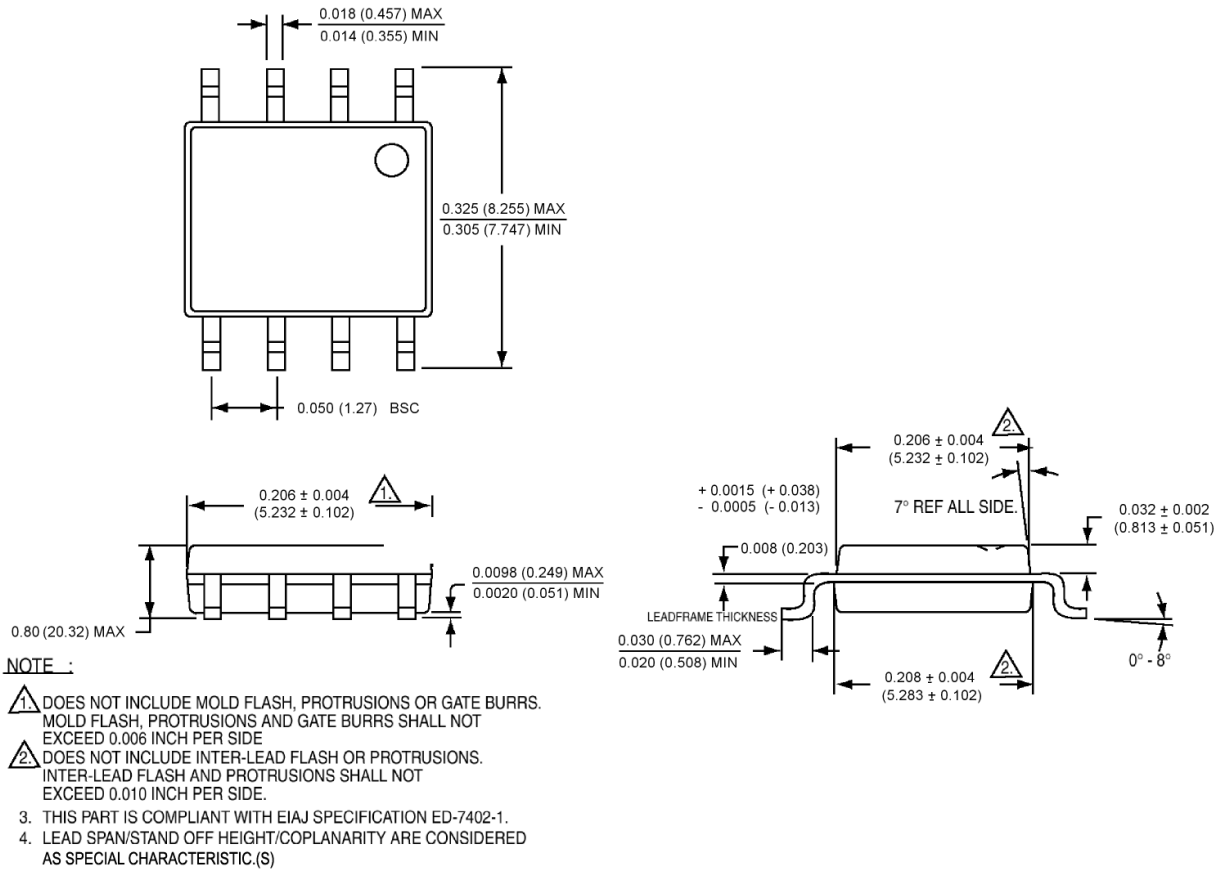

Figure 20. 8-pin Molded Small Outline Package (MW8), Package Number M08D

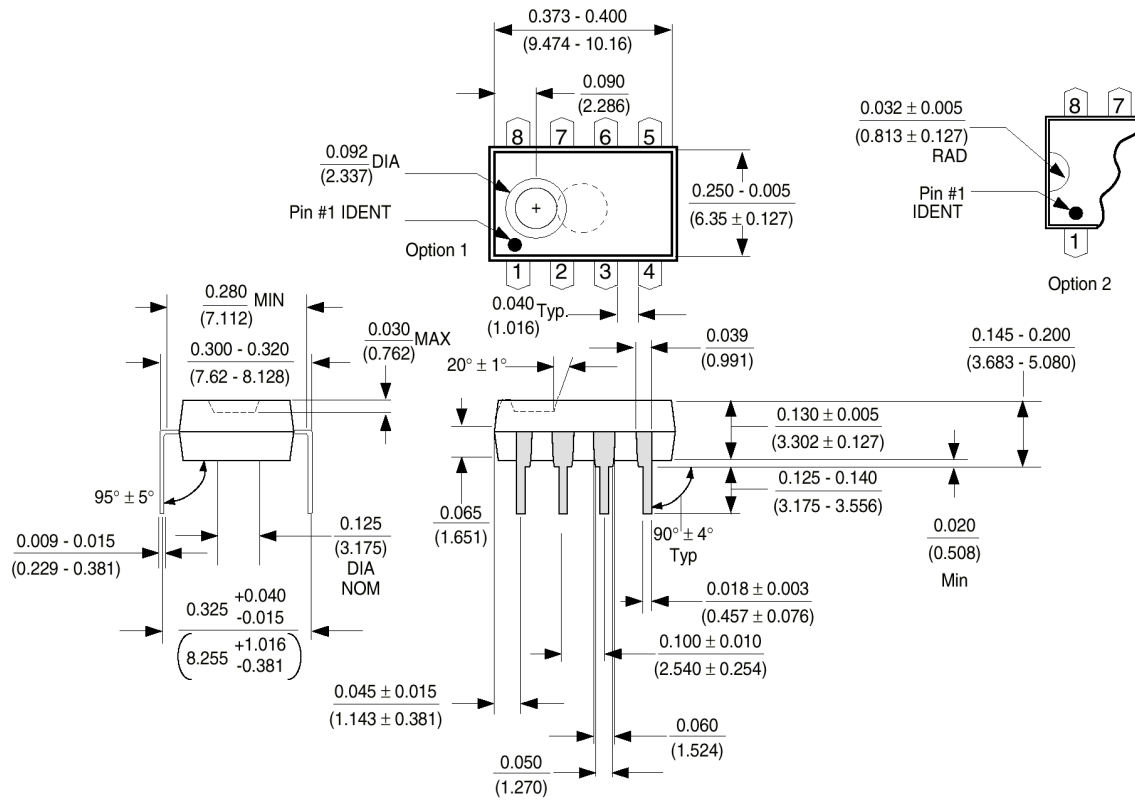
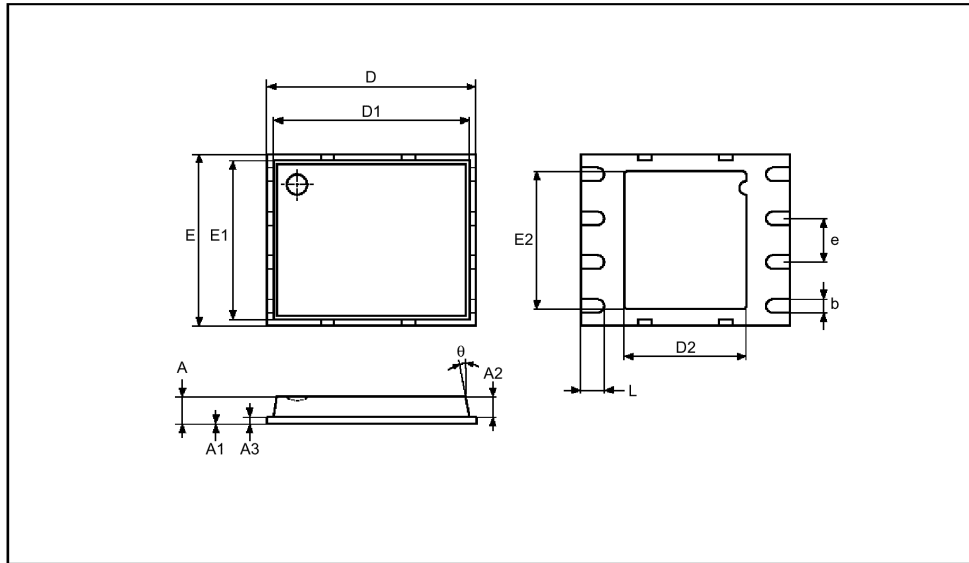

Figure 21. Molded Dual-in-Line Package (N), Package Number N08E



Note: Drawing is not to scale.

Symb.	mm			inches		
	Typ.	Min.	Max.	Typ.	Min.	Max.
A	0.85		1.00	0.0335		0.0394
A1		0.00	0.05		0.0000	0.0020
A2	0.65			0.0256		
A3	0.20			0.0079		
b	0.40	0.35	0.48	0.0157	0.0138	0.0189
D	6.20			0.2400		
D1	5.75			0.2264		
D2	3.40	3.20	3.60	0.1339	0.1260	0.1417
E	5.00			0.1969		
E1	4.75			0.1870		
E2	4.00	3.80	4.20	0.1575	0.1496	0.1654
e	1.27			0.0500		
L	0.60	0.50	0.75	0.0236	0.0197	0.0295
θ			12°			12°

Figure 22. 8-pin MLF Leadless Package

Contact Information

International Headquarters

Saifun Semiconductors Ltd.
ELROD Building
45 Hamelach St.
Sappir Industrial Park
Netanya 42504
Israel

Tel.: +972-9-892-8444

Fax: +972-9-892-8445

Email: tech_support@saifun.com

<http://www.saifun.com>

United States

Saifun Semiconductors Inc.
2350 Mission College Blvd.
Suite 1070
Santa Clara, CA 95054
U.S.A.

Tel: +1-408-982-5888

Fax: +1-408-982-5890

Revision History

Rev	Date	Description of Change
0.0	05-Sep-02	Initial release
1.0	05-Dec-02	Editing and review
1.1	26-Aug-03	Endurance, MLF Package and t_{DH}

© Saifun Semiconductors Ltd. 2003

Saifun reserves the right, without notice, to change any of the products described in this guide, in order to improve functionality, reliability or design. Saifun assumes no liability arising from the application or use of any product described in this guide; and under its patent rights, gives no authorization for the use of this product or associated products. Saifun makes no warranty for use of its products, other than expressly provided by Saifun in any applicable warranty. The Buyer will not hold Saifun responsible for direct or indirect damages and expenses, as well as any claim of injury or death, associated with the unauthorized use, including claims of manufacture or design negligence.

Saifun and Saifun NROM are trademarks or registered trademarks of Saifun Semiconductors Ltd. Other company and brand products and service names are trademarks or registered trademarks of their respective holders.

Life Support Policy

Saifun's products are not authorized for use as critical components in life support devices or systems without the express written approval of the President of Saifun Semiconductors Ltd. As used herein:

1. Life support devices or systems are devices or systems which, (a) are intended for surgical implant into the body, or (b) support or sustain life, and whose failure to perform, when properly used in accordance with instructions for use provided in the labeling, can be reasonably expected to result in a significant injury to the user.
2. A critical component is any component of a life support device or system whose failure to perform can be reasonably expected to cause the failure of the life support device or system, or to affect its safety or effectiveness.

Copyright © Each Manufacturing Company.

All Datasheets cannot be modified without permission.

This datasheet has been download from :

www.AllDataSheet.com

100% Free DataSheet Search Site.

Free Download.

No Register.

Fast Search System.

www.AllDataSheet.com