



NJL5190K/92K

GENERAL PURPOSE PHOTO REFLECTOR

■ GENERAL DESCRIPTION

The NJL5190K/5192K are the single-in-line super miniature and super thin general purpose photo reflectors, which consist of high output infrared emitting and high sensitive Si photo transistor, and attain high cost performance.

■ FEATURES

- Super miniature, super thin type
- Built-in visible light cut-off filter.
- High output, high S/N ratio.

■ APPLICATIONS

- End detector of video, audio tape.
- Rotation detection and control of various motors, audio turntables.
- Paper edge detection and mechanism timing detection of facsimile printer, X-Y recorder.
- Reading film information and mechanism timing detection of camera.
- Reading out the characters of bar code reader, encoder and the automatic vending machine.
- Various detection of industrial system, such as FDD, Robot.

■ ABSOLUTE MAXIMUM RATINGS (Ta=25°C)

PARAMETER	SYMBOL	RATINGS	UNIT
Emitter			
Forward Current (Continuous)	IF	30	mA
Reverse Voltage (Continuous)	VR	6	V
Power Dissipation	PD	45	mW
Detector			
Collector-Emitter Voltage	VCEO	16	V
Emitter-Collector Voltage	VECO	6	V
Collector Current	IC	10	mA
Collector Power Dissipation	PC	25	mW
Coupled			
Total Power Dissipation	Ptot	60	mW
Operating Temperature	Topr	-20 ~ +85	°C
Storage Temperature	Tstg	-30 ~ +85	°C
Soldering Temperature	Tsol	260(10sec. 1.5mm from body)	°C

■ ELECTRO-OPTICAL CHARACTERISTICS (Ta=25°C)

PARAMETER	SYMBOL	TEST CONDITION	MIN	TYP	TYP	UNIT
Emitter						
Forward Voltage	VF	IF=4mA	—	—	1.4	V
Reverse Current	IR	VR=6V	—	—	10	μA
Capacitance	Ct	VR=0V, f=1MHz	—	25	—	pF
Detector						
Dark Current	ICEO	VCE=10V	—	—	0.2	μA
Collector-Emitter Voltage	VCEO	IC=100μA	16	—	—	V
Coupled						
Output Current	IO	IF=4mA, VCE=2V, d=0.7mm	50	—	150	μA
Operating Dark Current	ICEOD	IF=4mA, VCE=2V	—	—	0.2	μA
Rise Time	tr	IO=100μA, VCE=2V, RL=1KΩ, d=0.7mm	—	30	—	μS
Fall Time	tf	IO=100μA, VCE=2V, RL=1KΩ, d=0.7mm	—	30	—	μS



NJL5190K/92K

■ OUTLINE (typ.) Unit : mm

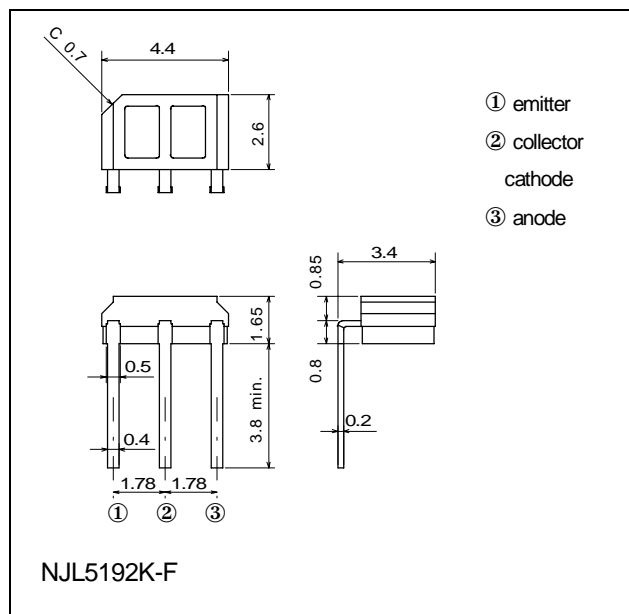
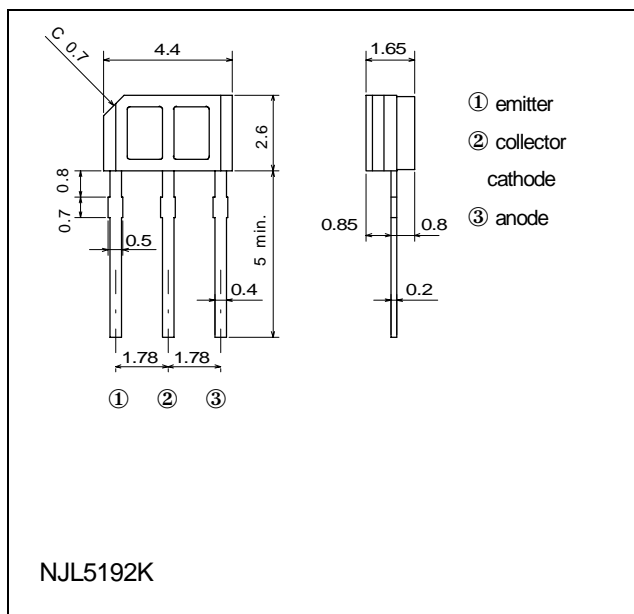
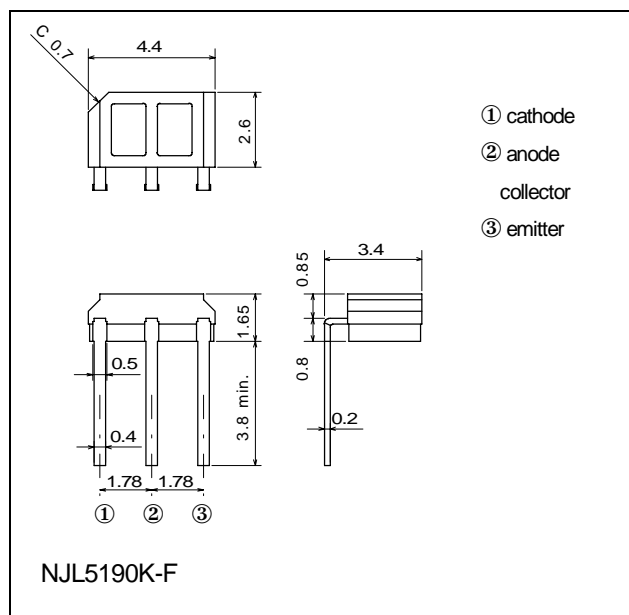
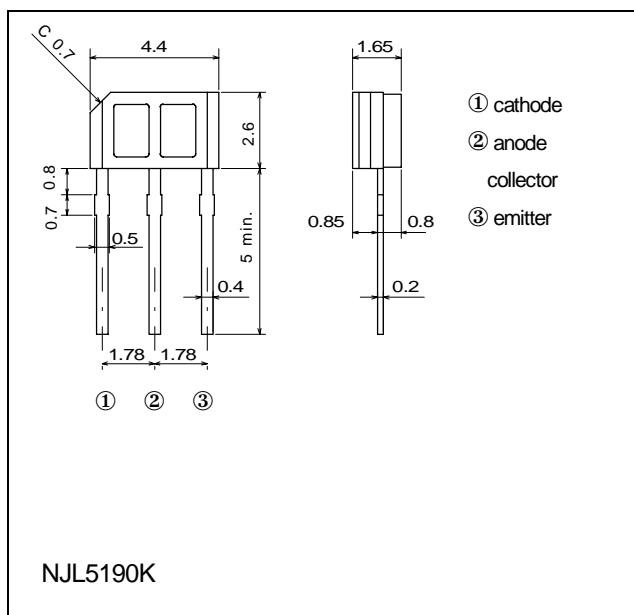

NJL5190K/92K

MEASURING SPECIFICATION FOR OUTPUT CURRENT

The output current can be measured when reflected at the aluminum

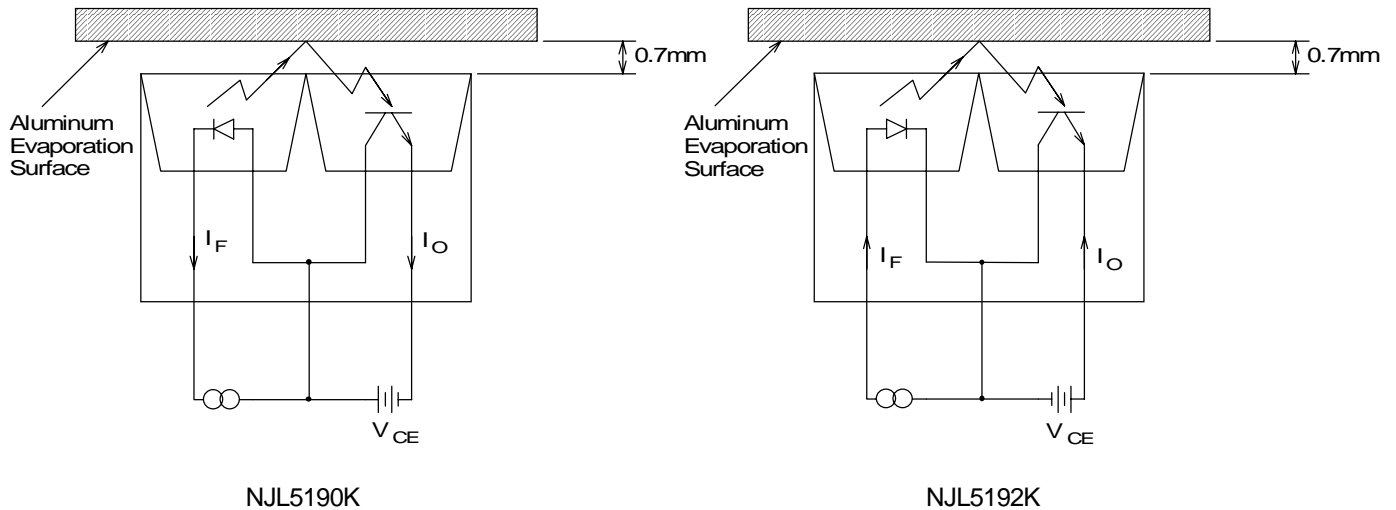

MEASURING CIRCUIT FOR OPERATING DARK CURRENT

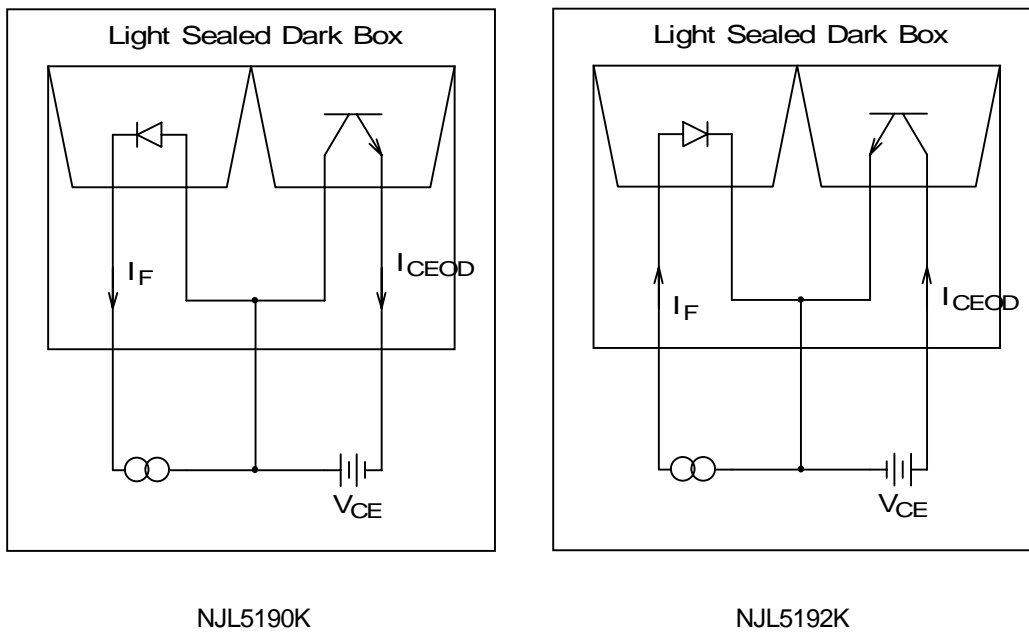

MEASURING SPECIFICATION FOR EDGE RESPONSE

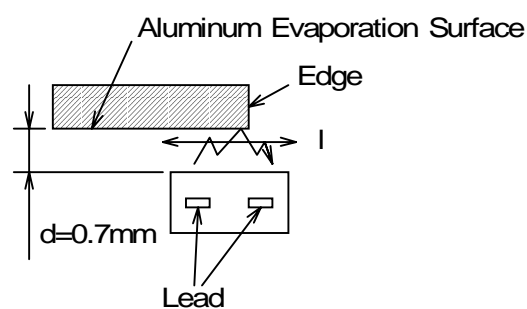

NJL5190K/92K

MEASURING CIRCUIT FOR RESPONSE TIME

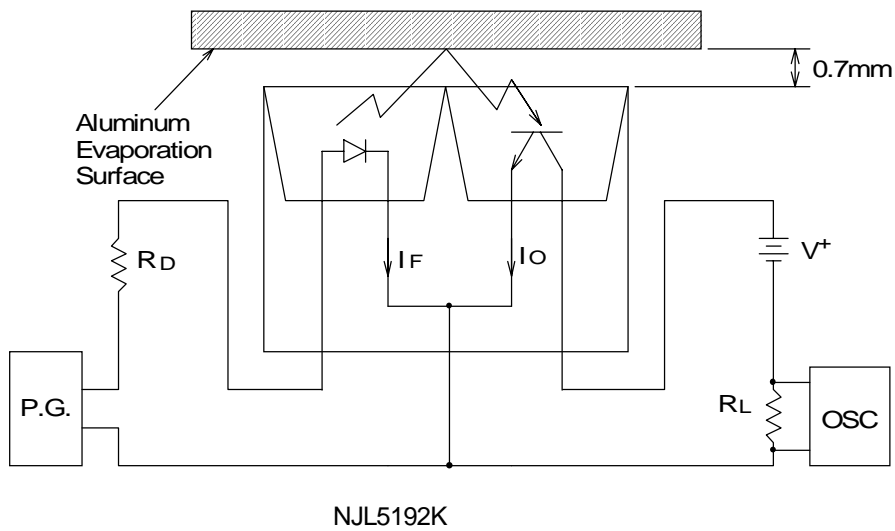
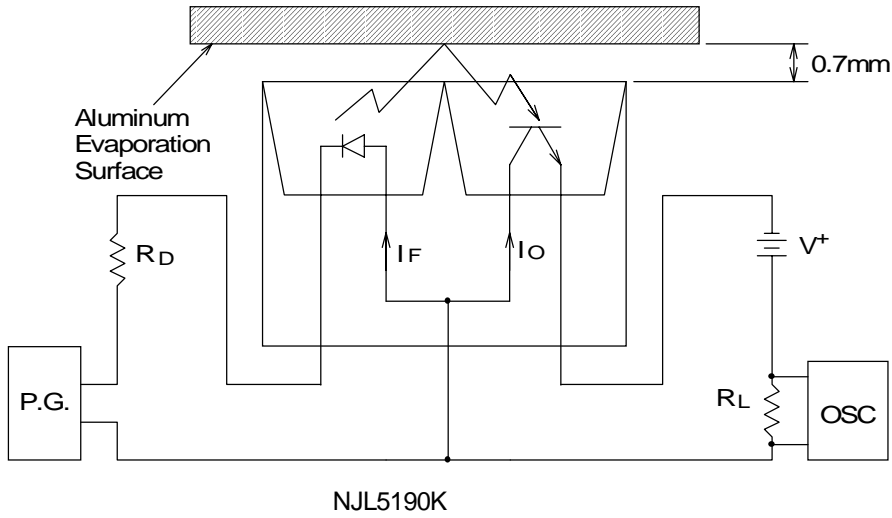

MAXIMUM RATING CURVES

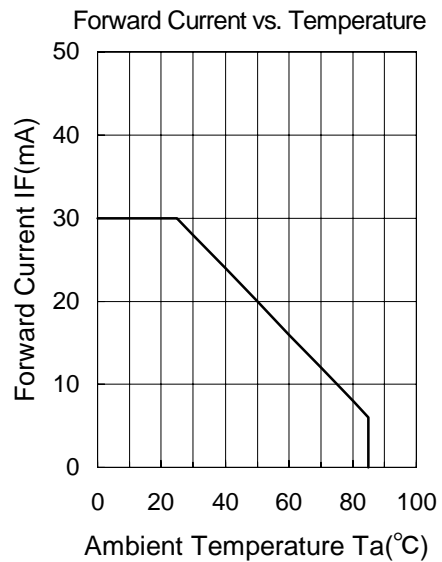
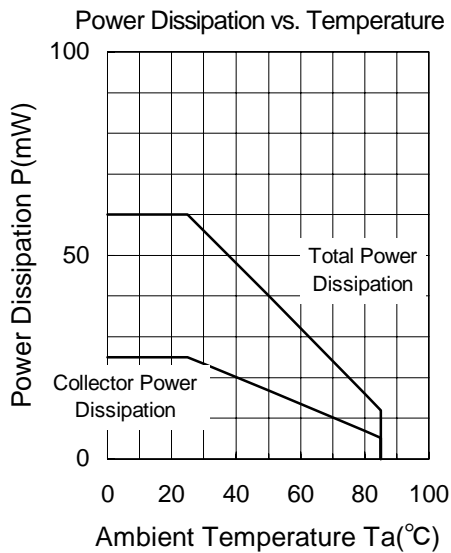

NJL5190K/92K

■ TYPICAL CHARACTERISTICS

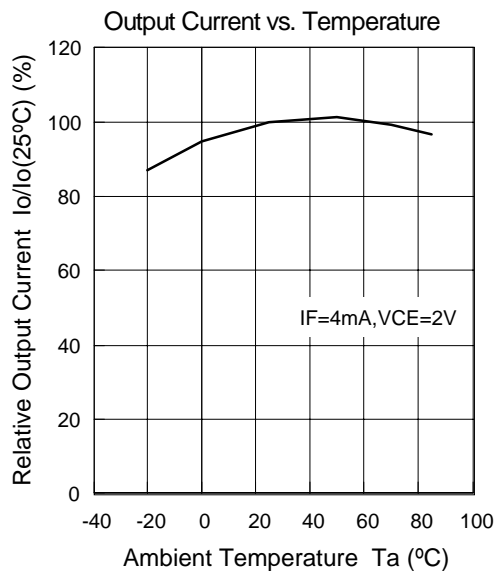
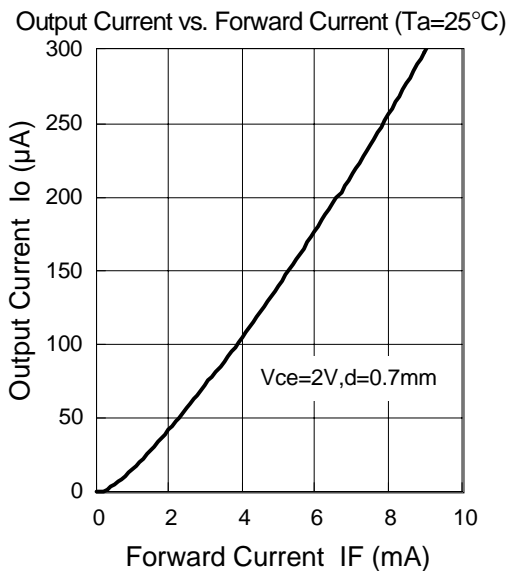
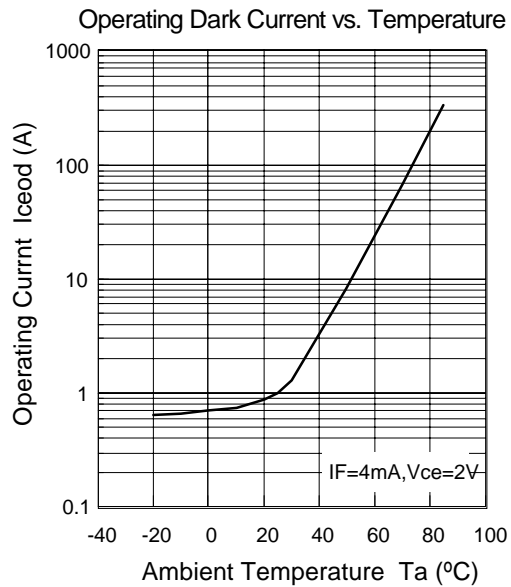
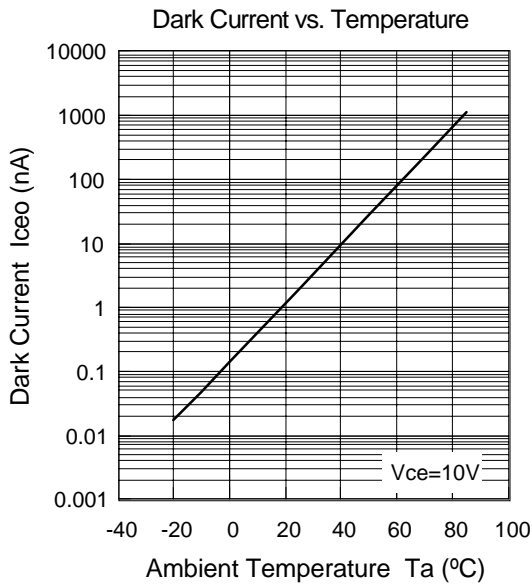
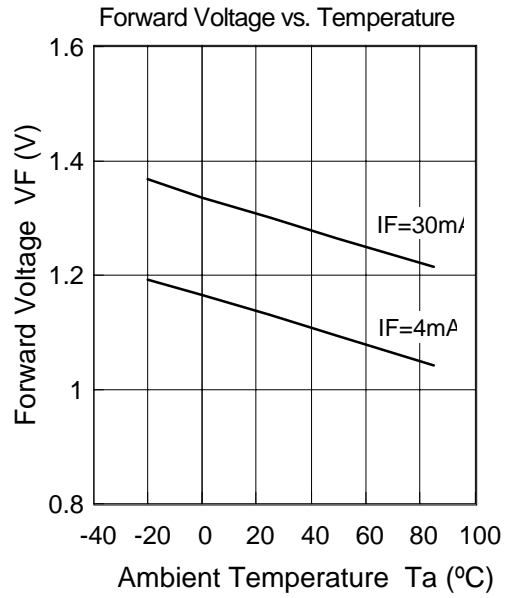
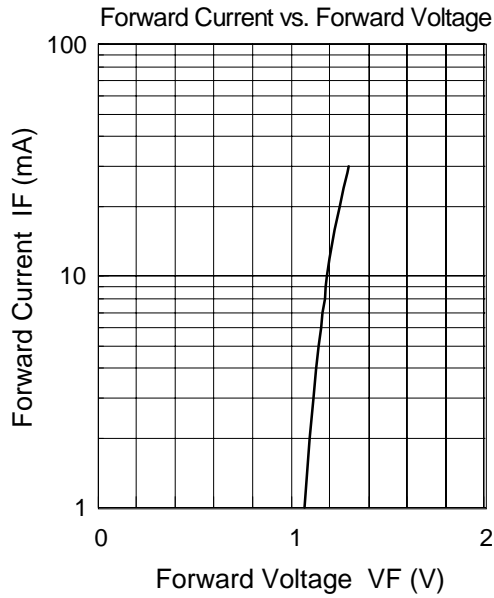

NJL5190K/92K

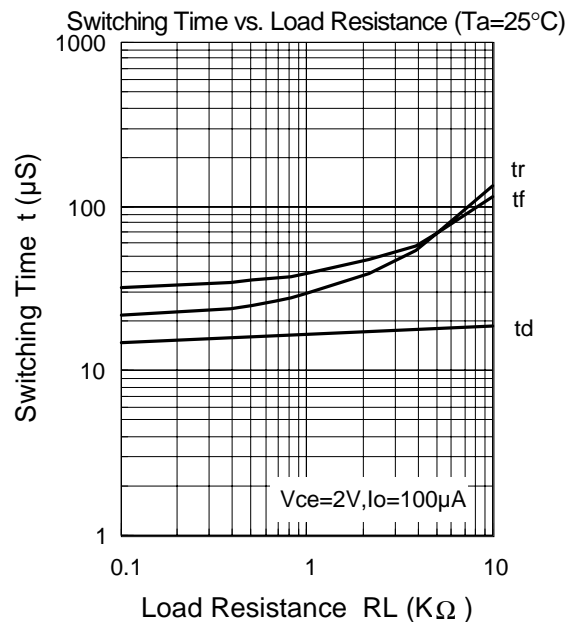
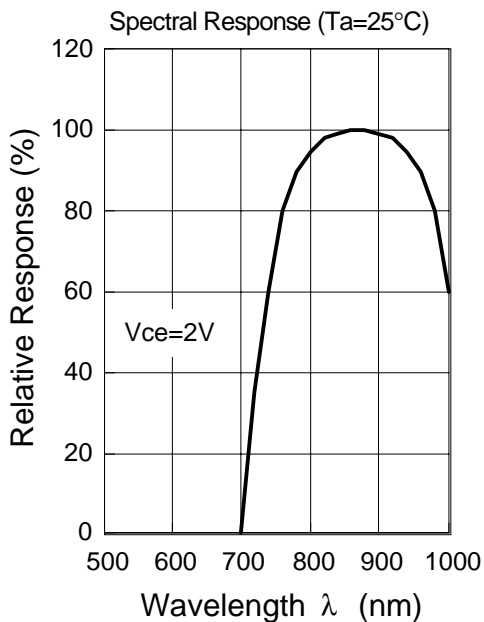
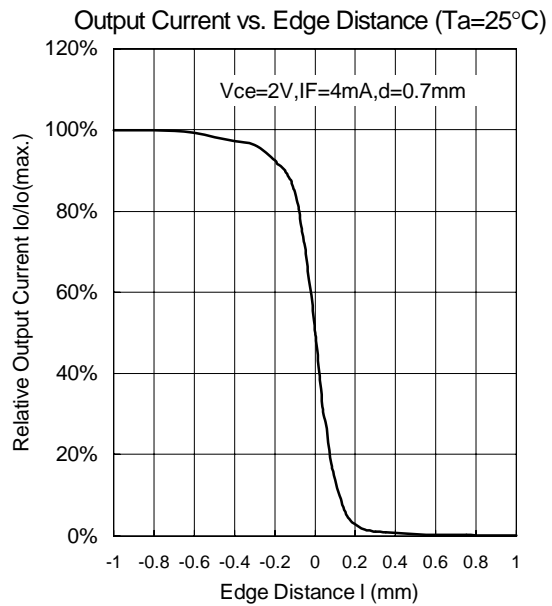
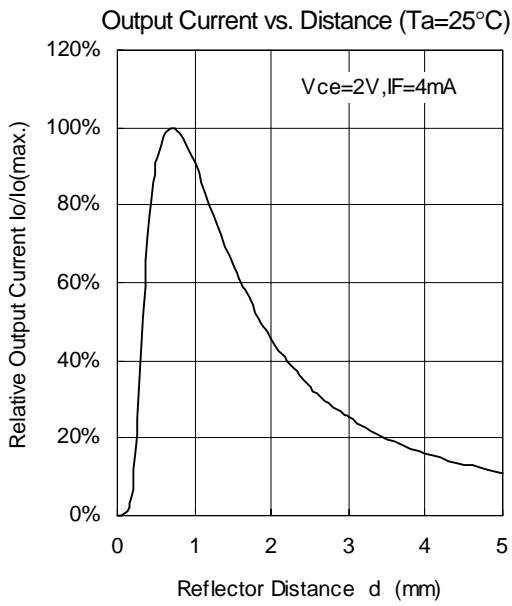
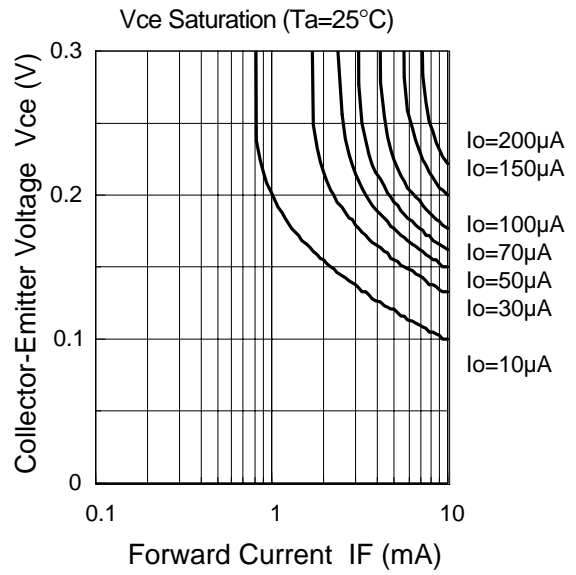
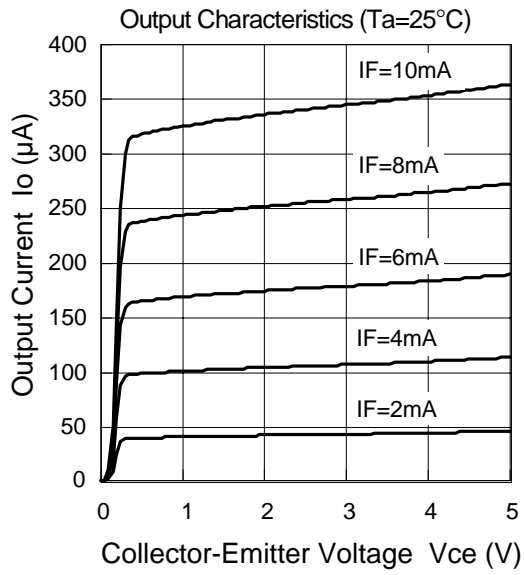

PRECAUTION FOR HANDLING

1. Soldering

- 1) Avoid the reflow method and solder to touch the body of the device during wave soldering. This is to prevent changes in optical characteristics of the device.
- 2) Recommended in Soldering

Temperature	Time Lead	Soldering Position
260°C maximum	less than 10 seconds	At least 1.5mm from body
- 3) Soldering is recommended to be done in as short period of the time as possible by controlling the temperature of the soldering iron or by the iron of less than 15 watts.
- 4) The resin gets softened right after soldered, so, the following care has to be taken.
 - Not to contact the lens surface to anything
 - Not to dip the device into water or any solvents
- 5) It is recommended not to solder when the leads or between the lead get pulled, depressed or twisted.
- 6) In the case of using rosin flux, be careful to avoid contact with the lens surface. If the lens is covered with the flux, the specified characteristics cannot be achieved.

2. Post Solder Cleaning

- 1) Organic solvents for flux removal like trichloroethylene, acetone, thinner etc, might attach the lens surface. It is preferable to use less reactive solvents, Methyl Alcohol, Isopropyle Alcohol.
- 2) Cleaning Operation

Cleaning Solvent Temperature :	35°C maximum
Dipping Time	: 3 minute maximum

3. Attention in handling

- 1) Treat not to touch the lens surface.
- 2) Avoid dust and any other foreign materials(flux, paints, bonding material, etc.) on the lens surface.
- 3) Never to apply reverse voltage(VEC) of more than 6V on the photo transistor when measuring the characteristics or adjusting the system. If applied, it causes to lower the sensitivity.
- 4) When mounting, special care has to be taken on the mounting position and tilting of the device because it is very important to place the device to the optimum position to the object.

4. Storage

The leads are silver plated and they are discolored if the device is left open to the air for long after taken out of the envelop. It causes deterioration of soldering characteristics. Mount the device as short as possible after opening the envelope.

NJL5190K/92K

MEMO

[CAUTION]

The specifications on this databook are only given for information, without any guarantee as regards either mistakes or omissions. The application circuits in this databook are described only to show representative usages of the product and not intended for the guarantee or permission of any right including the industrial rights.