



ELECTRONICS, INC.
44 FARRAND STREET
BLOOMFIELD, NJ 07003
(973) 748-5089

NTE1531 Integrated Circuit Voltage Regulator for Electronic Tuning System

Description:

The NTE1531 is a voltage regulator for use with a varactor tuner or electronic tuning control.

Absolute Maximum Ratings: ($T_A = +25^\circ\text{C}$ unless otherwise specified)

Maximum Input Voltage (+B ₁ , +B ₂ , CLK), V _{B1} , V _{B2} , V _{CLKmax}	21V
Allowable Power Dissipation, P _{Dmax}	1W
Operating Temperature Range, T _{opg}	-20° to +70°C
Storage Temperature Range, T _{stg}	-40° to +125°C

Recommended Operation Conditions: ($T_A = +25^\circ\text{C}$ unless otherwise specified)

Parameter	Symbol	Min	Typ	Max	Unit
V _{ref} Output Current	I _{ref}	-10	-	0	mA
V _{DD} Output Current	I _{DD}	-30	-	0	mA
$\overline{\text{INH}}$ Output Current	$\overline{I_{\text{INH}}}$	-0.5	-	0	mA
BUC Output Current	$\overline{I_{\text{BUC}}}$	-0.8	-	0	mA
+B ₁ , +B ₂ Input Voltage	V _{B1} , V _{B2}	9	-	16	V

Operational Characteristics: ($T_A = +25^\circ\text{C}$, unless otherwise specified)

Parameter	Symbol	Conditions	Min	Typ	Max	Unit
V _{DD} Voltage	V _{DD(1)}	+B ₁ = +B ₂ = 9V, I _{DD} = 30mA, I _{ref} = 10mA, V _{ref} = 8V, T _A = -20° to +70°C	V _{ref} -0.3	-	8.5	V
	V _{DD(2)}	+B ₁ = +B ₂ = 16V, I _{DD} = 30mA, I _{ref} = 10mA, V _{ref} = 8V, T _A = -20° to +70°C	V _{ref} -0.3	-	10	V
V _{DD} Voltage (At Back-Up Time)	V _{DD(3)}	+B ₂ = 9 to 16V, I _{DD} = 4mA, +B ₁ opened.	4.5	-	5.5	V
V _{DD} Voltage	V _{DD(4)}	V _{CLK} = +B ₂ = 9V, I _{DD} = 18mA, I _{ref} = 10mA, V _{ref} = 8V, T _A = -20° to +70°C, +B ₁ opened.	V _{ref} -0.3	-	8.5	V



Operational Characteristics (Cont'd): ($T_A = +25^\circ\text{C}$, unless otherwise specified)

Parameter	Symbol	Conditions	Min	Typ	Max	Unit
V_{DD} Voltage	$V_{DD(5)}$	$V_{CLK} = +B_2 = 16\text{V}$, $I_{DD} = 18\text{mA}$, $I_{ref} = 10\text{mA}$, $V_{ref} = 8\text{V}$, $T_A = -20^\circ$ to $+70^\circ\text{C}$, $+B_1$ opened.	$V_{ref}-0.3$	–	10	V
Radio Back-Up Signal Voltage	$\overline{V_{BUC}}$	$+B_1 = +B_2 = 9.15$ to 16V , $V_{ref} = 8\text{V}$	$0.78V_{DD}$	–	V_{DD}	V
Clock Back-Up Signal Voltage	$\overline{V_{INH1}}$	$+B_1 = +B_2 = 9.15$ to 16V , $V_{ref} = 8\text{V}$	$0.78V_{DD}$	–	V_{DD}	V
Radio Back-Up Signal Rise Voltage	$V_{TH \overline{BUC} UP}$	$+B_1 = +B_2$, $V_{ref} = 8\text{V}$, $I_{ref} = 10\text{mA}$	8.9	–	9.3	V
Radio Back-Up Signal Hysteresis	$V_{TH \overline{BUC} DN}$	$+B_1 = +B_2$, $V_{ref} = 8\text{V}$, $I_{ref} = 10\text{mA}$	50	–	200	mV
BUC Delay Time at +B Step Input	t_D	$+B_1 = +B_2 = 13.2\text{V}$, $C = 22\mu\text{F}$, $R = 22\text{k ohm}$	85	–	400	ms
Current Dissipation	$I_{CC(1)}$	$+B_1 = +B_2 = 13.2\text{V}$, $I_{DD} = 30\text{mA}$, $I_{ref} = 10\text{mA}$	–	70	–	mA
	$I_{CC(2)}$	$+B_2 = 13.2\text{V}$, no load, $+B_1$ opened.	–	0.63	1.4	mA
V_{ref} Thermal Drift	$ \Delta V_{ref} $	$T_A = -10$ to $+60^\circ\text{C}$, $V_{ref} = 8\text{V}$ (25°C)	–60	0	60	mV

Logic Table:

B1	B2	CLK	V_{DD}	V_{ref}	\overline{BUC}	$\overline{INH1}$	Condition
L	H	L	5V	0V	L	L	When back-up of time
H	H	L	9V	8V	H	H	radio on
L	H	H	9V	8V	L	H	read out time when radio off
H	H	H	9V	8V	H	H	read out time when radio on

NOTE: This device is for *REPLACEMENT ONLY!* No application notes are available.

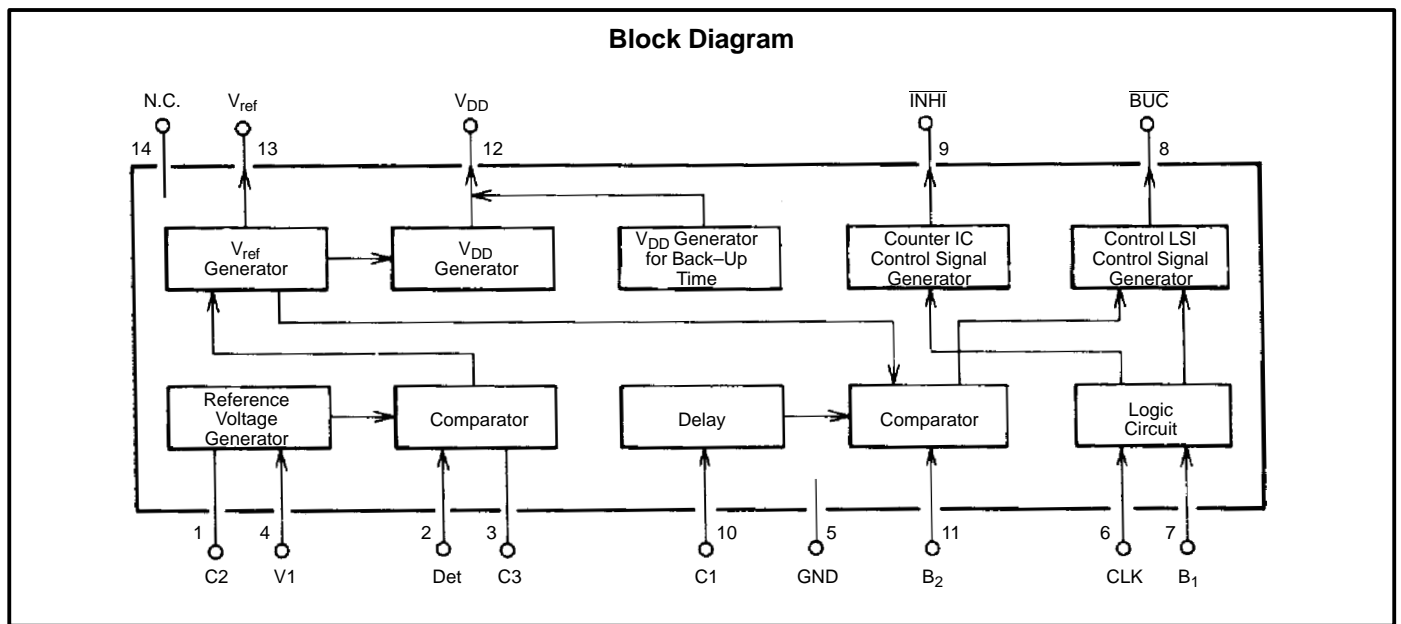

Pin Connection Diagram

