

OET SERIES - TRIPLE OUTPUT, 25 WATT

DESCRIPTION

OET triple output DC/DC converters provide 25 Watts of output power in an industry standard package. The OET series features excellent efficiency and industry-leading power density. The OET features open-frame packaging to provide maximum useable power with minimal thermal constraints. These units are fully compatible with production board washing processes.

FEATURES

- Triple Output 2" x 2"
- Open-Frame Construction
- 1.5 Million Hours MTBF
- Short Circuit and Overvoltage Protection
- Input Undervoltage Lockout
- 24V or 48V Input Versions
- 1500V Isolation
- 100°C Baseplate Operation

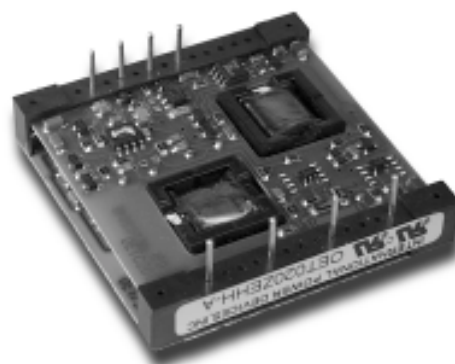

TECHNICAL SPECIFICATIONS

Input	
Voltage Range	
24 VDC Nominal	18 - 36 VDC
48 VDC Nominal	34 - 75 VDC
Turn On Voltage 24V/48V Models	<17V / <34V
Turn On Hysteresis	1V Nominal
Reflected Ripple Input Current	50 mA pk-pk
Input Reverse Voltage Protection	Shunt Diode

Output	
Setpoint Accuracy	±1%
Line Regulation V_{in} Min. - V_{in} Max., I_{out} Rated	0.2% V_{out}
Load Regulation I_{out} Min. - I_{out} Max., V_{in} Nom.	0.5% V_{out}
Secondary Output Regulation, All Line/Load Conditions	10% V_{out}
Minimum Output Current	10 % I_{out} rated
Dynamic Regulation, Loadstep	25% I_{out}
Pk Deviation	4% V_{out}
Settling Time	500 μ s
Short Circuit And Overcurrent Protection	Shutdown and Self-Recovering
Power Limit Threshold Range	110 - 130%
Short Circuit	200% I_{out} Nom.
OVP Trip Range	115 - 140% V_{out} Nom.
OVP Type	Self-Recovering

General	
Switching Frequency	500 kHz
Turn-On Time	10ms
Remote Shutdown	Positive Logic
Isolation	
Input - Output	1500 VDC
Input - Case	1050 VDC
Output - Case	1050 VDC
Temperature Coefficient	0.03%/°C
Case Temperature	
Operating Range	-40 to +100°C
Storage Range	-40 to +125°C
Thermal Shutdown Range	105 to 115°C
Humidity Max., Non-Condensing	95%
Vibration, 3 Axes, 5 Min Each	5 g, 10 - 55 Hz
MTBF† (Bellcore TR-NWT-000332)	1.5 x 10 ⁶ hrs
Safety	UL, CUL, TUV
Weight (approx.)	1.3 oz

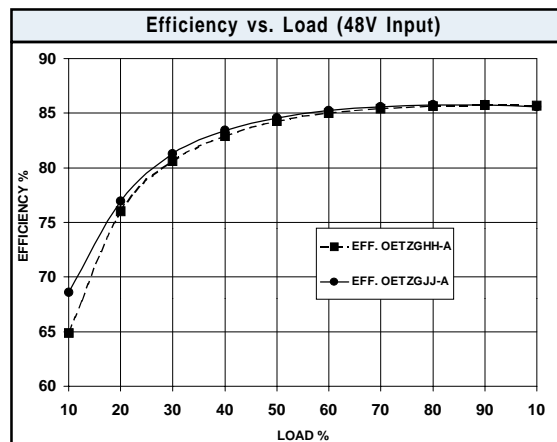

Notes
† MTBF predictions may vary slightly from model to model.
Specifications typically at 25°C, normal line, and full load, unless otherwise stated.
Soldering Conditions: I/O pins, 260°C, ten seconds; fully compatible with commercial wave-soldering equipment.
Safety: Agency approvals may vary from model to model. Please consult factory for specific model information.
Units are water-washable and fully compatible with commercial spray or immersion post wave-solder washing equipment.

OET SERIES - TRIPLE OUTPUT, 25 WATT

MODELS - (See the last page of this file for options.)

Vin (Volts)	Vin Range (Volts)	Iin Max.* (Amps)	Vout (Volts)	Iout Rated (Amps)	Ripple & Noise Pk-Pk (mV)	Efficiency Typ. **	Model
24	18 - 36	1.4	3.3, -12	3.5, -0.35	50/120/120	85%	OET020YEH-A
24	18 - 36	1.4	3.3, -15	3.5, -0.28	50/150/150	85%	OET020YEJ-A
24	18 - 36	1.8	5, -12	3.5, -0.31	50/120/120	86%	OET025YGH-A
24	18 - 36	1.8	5, -15	3.5, -0.25	50/150/150	86%	OET025YJJ-A
48	34 - 75	0.7	3.3, -12	3.5, -0.35	50/120/120	85%	OET020ZEH-A
48	34 - 75	0.7	3.3, -15	3.5, -0.28	50/150/150	85%	OET020ZEJ-A
48	34 - 75	0.9	5, -12	3.5, -0.31	50/120/120	85%	OET025ZGH-A
48	34 - 75	0.9	5, -15	3.5, -0.25	50/150/150	85%	OET025ZJJ-A

Denotes advanced product release. Consult factory for product availability.

* Maximum input current at minimum input voltage, maximum rated output power.

** At nominal Vin, rated output.

MECHANICAL DRAWING

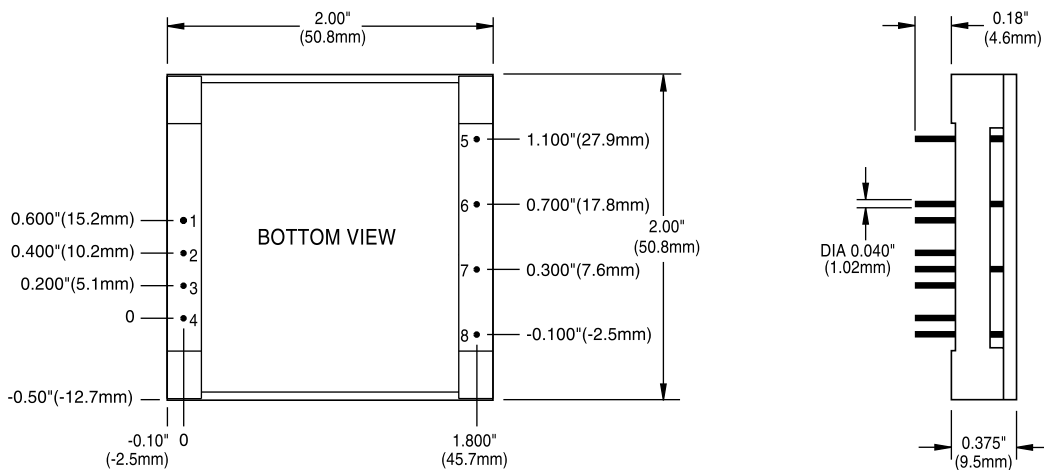

Thermal Impedance	
Natural Convection	11.0 °C/W
100 LFM	7.5 °C/W
200 LFM	5.0 °C/W
300 LFM	3.7 °C/W
400 LFM	3.1 °C/W

Note:
Thermal impedance data is dependent on many environmental factors. The exact thermal performance should be validated for specific application.

Pin	Function
1	+V _{in}
2	-V _{in}
3	case
4	enable
5	+V _{out} (aux)
6	+V _{out} (main)
7	common
8	-V _{out} (aux)

Tolerances	
Inches:	(Millimeters)
.XX ± 0.020	.X ± 0.5
.XXX ± 0.010	.XX ± 0.25
Pin:	
± 0.002	± 0.05
(Dimensions as listed unless otherwise specified.)	

OPTIONS

When ordering equipment options, use the following suffix information. Select the option(s) that you prefer and add them to the model number. Example ordering options are located below the options table.

OPTION	SUFFIX	APPLICABLE SERIES	REMARKS
Negative Logic	N	HAS, HBD, HBS, HES, LES, QBS, QES, TES, TQD	TTL "Low" Turns Module ON TTL "High" Turns Module OFF
Lucent Compatible Trim	T	HAS, HBD, HBS, HES, QBS, QES	
Terminal Strip	TS	XWS, XWD, XWT	
Trim	1	IAS, LES	
Enable	2	IAD, IAS, LES, SMS	
Trim and Enable	3	IAS, LES	
Current Share	4	SMS	
Headerless	Y	Encapsulated EWS, IWS, OWS	
PIN LENGTH AND HEATSINK OPTIONS			Standard Pin Length is 0.180" (4.6mm)
0.110" (2.8mm) Pin Length	8	All Units (Except SMS)	
0.150" (3.8mm) Pin Length	9	All Units (Except SMS)	
0.24" (6.1mm) Horizontal Heatsink	1H	All Units (Except DIP, SIP, and SM Packages)	Includes Thermal Pad
0.24" (6.1mm) Vertical Heatsink	1V	All Units (Except DIP, SIP, and SM Packages)	Includes Thermal Pad
0.45" (11.4mm) Horizontal Heatsink	2H	All Units (Except DIP, SIP, and SM Packages)	Includes Thermal Pad
0.45" (11.4mm) Vertical Heatsink	2V	All Units (Except DIP, SIP, and SM Packages)	Includes Thermal Pad
0.95" (24.1mm) Horizontal Heatsink	3H	All Units (Except DIP, SIP, and SM Packages)	Includes Thermal Pad
0.95" (24.1mm) Vertical Heatsink	3V	All Units (Except DIP, SIP, and SM Packages)	Includes Thermal Pad

Example Options: HBS050ZG-ANT3V = HBS050ZG-A with negative logic, Lucent compatible trim, and 0.95" vertical heatsink.

LES015YJ-3N = LES015YJ with optional trim and enable, negative logic.

QBS066ZG-AT8 = QBS066ZG-A with Lucent compatible trim and 0.110" pin length.

NUCLEAR AND MEDICAL APPLICATIONS Power-One products are not authorized for use as critical components in life support systems, equipment used in hazardous environments, or nuclear control systems without the express written consent of the President of Power-One, Inc.

TECHNICAL REVISIONS The appearance of products, including safety agency certifications pictured on labels, may change depending on the date manufactured. Specifications are subject to change without notice.