

Data Sheet
INTEGRATED CIRCUIT
2002 Nov 08

OM5428

General purpose triggering circuit

INTEGRATED ELECTRONIC SOLUTIONS
1 BUTLER DRIVE
HENDON SA 5014
AUSTRALIA



General purpose triggering circuit

OM5428

CONTENTS

1	FEATURES
2	GENERAL DESCRIPTION
3	QUICK REFERENCE DATA
4	ORDERING INFORMATION
5	PINNING INFORMATION
5.1	Pinning layout
5.2	Pin description
6	BLOCK DIAGRAM
7	FUNCTIONAL DESCRIPTION
7.1	Supply
7.2	Reset
7.3	Gate sense
7.4	Zero-crossing detector
7.5	Difference amplifier
7.6	Sawtooth generator
7.7	Output stage
8	LIMITING VALUES
9	CHARACTERISTICS
10	IMPORTANT: ELECTRICAL SAFETY WARNING
11	APPLICATION INFORMATION
12	PACKAGE OUTLINES
13	SOLDERING
13.1	Introduction
13.2	DIP
13.2.1	Soldering by dipping or by wave
13.2.2	Repairing soldered joints
13.3	SO
13.3.1	Reflow soldering
13.3.2	Wave soldering
13.3.3	Repairing soldered joints
14	DEFINITIONS
15	IES INFORMATION
16	DISCLAIMER ⁽¹⁾

(1) The contents of this document are subject to the disclaimer on page 16

General purpose triggering circuit

OM5428

1 FEATURES

- Adjustable proportional range
- Adjustable hysteresis
- Adjustable firing burst repetition time
- Adjustable pulse width
- Supplied from the mains
- Provides supply for external temperature bridge
- Low supply current, low dissipation

2 GENERAL DESCRIPTION

The OM5428 is a bipolar integrated circuit delivering negative pulses for triggering a triac. The flexibility of the circuit makes it suitable for a variety of applications, such as:

- Synchronous on/off switching
- Phase control
- Time-proportional control
- Temperature control
- Motor speed control

3 QUICK REFERENCE DATA
 $T_{amb} = 25^{\circ}\text{C}$

SYMBOL	PARAMETER	CONDITIONS	MIN	TYP	MAX	UNIT
$-V_{EE}$	DC supply voltage	derived from mains voltage	–	14	–	V
$-I_{EE}$	supply current	quiescent current	–	200	–	μA
I_{TRIG}	output current	set via gate resistor (R_g)	–	–	80	mA
t_w	zero crossing pulse width	$R_z = 500\text{K}\Omega\text{RC}$	–	100	–	μs
	sawtooth pulse width	$(R = 300\text{K}\Omega; C = 5\text{nF})$	–	100	–	μs
P_{tot}	total power dissipation	maximum	–	–	300	mW
T_{amb}	operating ambient temperature range		0	–	+125	$^{\circ}\text{C}$

4 ORDERING INFORMATION

TYPE NUMBER	PACKAGE		
	NAME	DESCRIPTION	VERSION
OM5428 P	DIP16	plastic dual in-line package; 16 leads (300 mil)	SOT38-1
OM5428 T	SO16	plastic small outline package; 16 leads; body width 3.9 mm	SOT109-1

General purpose triggering circuit

OM5428

5 PINNING INFORMATION

5.1 Pinning layout

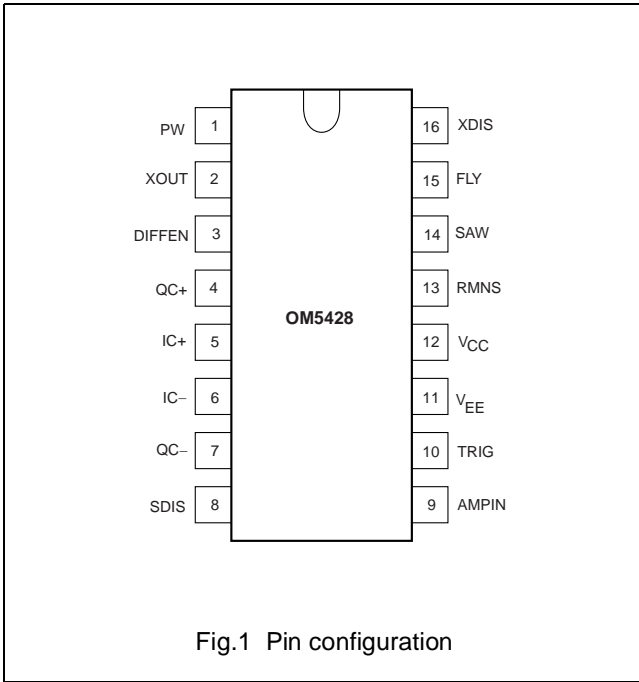

Fig.1 Pin configuration

5.2 Pin description

SYMBOL	PIN	DESCRIPTION
PW	1	pulse width control input
XOUT	2	zero-crossing detector output
DIFFEN	3	difference amplifier enable output
QC+	4	comparator non-inverting output
IC+	5	comparator non-inverting input
IC-	6	comparator inverting input
QC-	7	comparator inverting output
SDIS	8	triac gate sense disable input
AMPIN	9	output stage input
TRIG	10	output stage output
VEE	11	negative supply
VCC	12	positive supply
RMNS	13	external power resistor
SAW	14	sawtooth generator trigger input
FLY	15	sawtooth generator output
XDIS	16	zero crossing detector disable input

6 BLOCK DIAGRAM

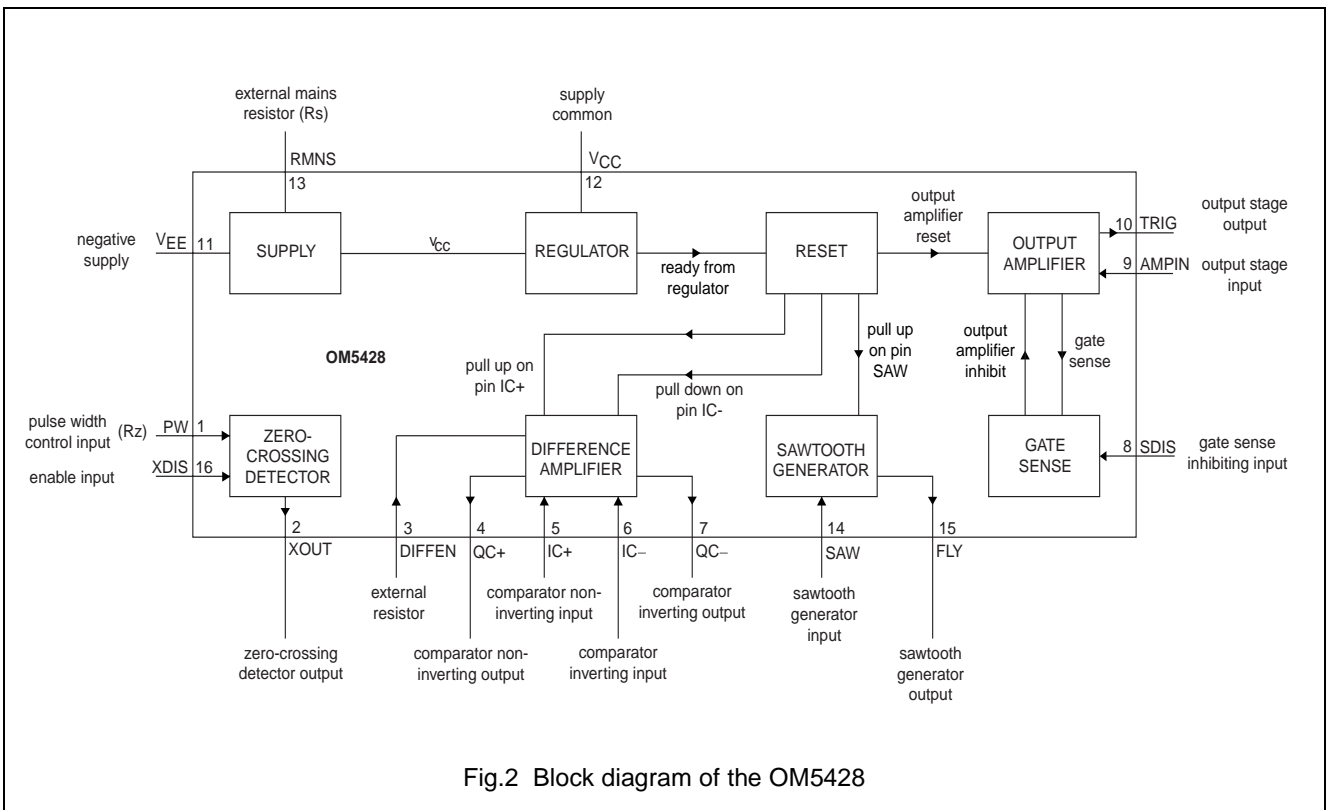

Fig.2 Block diagram of the OM5428

General purpose triggering circuit

OM5428

7 FUNCTIONAL DESCRIPTION

Fig.2 shows the functional block diagram of the OM5428. It comprises the following sections:

- d.c. supply derived from the mains via a dropping resistor (Rs);
- reset to ensure correct startup;
- gate sense for reduction in the number of pulses produced when firing the triac;
- zero-crossing detector for synchronization of the trigger pulses;
- difference amplifier passing a signal from a sensor, or indication of a potentiometer setting or switch position, etc.;
- ramp function generator operating as the sawtooth oscillator in time proportional or phase control;
- output amplifier amplifying trigger pulses and driving the triac gate.

7.1 Supply

The OM5428 has been designed so that it is supplied directly from mains voltage. For this purpose a regulator circuit is included to limit the DC supply voltage. An external resistor Rs (mains voltage rated) is connected between the mains active and pin RMNS; V_{CC} is connected to the neutral line. A smoothing capacitor C1 is connected between V_{CC} and V_{EE}. The circuit produces a negative supply voltage at V_{EE}, which may be used to supply an external circuit such as a temperature sensing bridge.

During the negative half of mains, current through the external voltage dropping resistor Rs charges the external smoothing capacitor C1 to the shunt voltage of the regulator. The value of Rs should be chosen such that it can supply the current for the OM5428, plus the charge required to drive the triac gate and any external (peripheral) circuits connected to V_{EE}

by recharging the smoothing capacitor C1 on the mains negative half cycles. Any excess current is bypassed through the shunt transistor of the regulator. The maximum rated current must not be exceeded.

During the positive half of the mains cycle the external smoothing capacitor C1 supplies the circuit. Its capacitance must be large enough to maintain the supply voltage above the minimum specified limit.

A suitable VDR may be connected across the mains to provide protection for the OM5428 and the triac against mains-born transients.

7.2 Reset

A reset circuit providing four reset functions throughout the OM5428 has been included.

Initially the reset signal ensures that trigger pulses are not produced until V_{EE} has reached its minimum value and C1 is fully charged. The input SAW (pin14) to the sawtooth generator is also held at a low state until the reset threshold has been reached.

During start-up the reset is also responsible for holding the input pins to the difference amplifier, IC+ (pin 5) at a high state and IC- (pin 6) at a low state. As a result, functions such as soft and hard start while phase firing can be realised.

7.3 Gate sense

Included in the OM5428 is a function that is capable of determining the state of the triac. Used to inhibit the output amplifier, the gate sense circuit ensures that multiple gate pulses are not produced, hence reducing overall current consumption.

7.4 Zero-crossing detector

The OM5428 contains a zero-crossing detector to produce pulses

that coincide with the zero crossings of the mains voltage to minimise RF interference and transients on the mains supply.

If the load to be driven is purely resistive, the synchronization voltage is obtained direct from the mains via a resistor. As a result trigger pulses start shortly before, and end shortly after, each zero-crossing of the mains voltage. In this manner radio interference is reduced to a minimum.

If the load contains an inductive component, the synchronization will be produced by the internal gate sense circuit rather than the zero-crossing detector. The trigger pulse is then produced at the earliest possible moment, i.e. immediately following zero-crossing of the phase-shifted load current.

During phase control the zero-crossing detector is used to generate a sawtooth voltage synchronous with the mains. As soon as the d.c. control voltage corresponding to a preset trigger angle is exceeded the output is pulsed.

The pulse width control input PW (pin 1) allows adjustment of the pulse width at output XOUT (pin 2), to the value required for the triac. This is done by choosing the value of external synchronization resistor Rz between PW and the AC mains. The pulse width is determined by the amount of current flowing to or from pin PW. Any current exceeding 9uA will result in the output of the zero-crossing detector being disabled. The zero-crossing detector output is also inhibited when the XDIS input (pin 16) is HIGH, and enabled when LOW, e.g. connected to V_{EE}.

The pulse width can be determined using the following formula:

$$PW = 2 \left(\frac{\text{asin} \left(\frac{9 \times 10^{-6} \cdot R_z}{V_{\text{mains(pk)}}} \text{rad} \right)}{100\pi} \right) \text{ s}$$

General purpose triggering circuit

OM5428

Output XOUT, which produces negative-going output pulses, is an n-p-n open-collector output that for some applications may require an external pull-up resistor connected to V_{CC} .

7.5 Difference amplifier

IC+ and IC- (pins 5 and 6) are differential inputs of the comparator or differential amplifier, with QC+ and QC- (pins 4 and 7) as complementary outputs. QC+ and QC- are n-p-n open collector outputs requiring external collector resistors to V_{CC} . QC+ will be HIGH and QC- will be LOW when IC+ is higher than IC-.

IC+ and IC- are both the base drive of separate p-n-p transistors. In order for correct operation of the comparator, the input voltage on these pins should be set up such that current is able to be drawn from them. Such arrangements may involve a pot controlled voltage divider.

The comparator contains a current mirror source that is activated by a current out of DIFFEN (pin 3). The

current drawn from pin 3 determines the drive for the comparator outputs.

7.6 Sawtooth generator

The sawtooth generator may be used to produce bursts of trigger pulses, with the net effect that the load is periodically switched on and off. The firing burst repetition time is usually determined by an external resistor and capacitor connected to the sawtooth generator trigger input SAW (pin 14). The repetition time is approximately $0.4 \times RC$.

With a time-proportional switch, the ramp voltage produced by the sawtooth generator serves to provide the repetition frequency of load switching that can be adjusted with the control voltage.

In phase control, the flyback of the sawtooth is used as the drive signal for generating the trigger pulse.

The output FLY (pin 15) is an n-p-n open-collector output. During the flyback period of the sawtooth pulse the transistor is ON and is capable of sinking current.

7.7 Output stage

The output stage is driven via an internal pull-up and therefore may be inhibited by drawing current from input AMPIN (pin 9). The output has been designed to produce negative going pulses with respect to mains neutral. This allows a triac to be fired in its more sensitive regions, reducing the amount of gate current needed to latch the triac and hence reducing the overall current consumption.

The output TRIG (pin 10) is an n-p-n open-collector output capable of sinking current i.e. conventional current flow into the circuit.

A gate resistor R_g should be connected between the output TRIG and the triac gate to limit the output current to the minimum required by the triac. By doing this, the total supply current and the power dissipation of the IC are minimised. Output TRIG is protected with a diode to V_{EE} (pin 11) against damage by undershoot of the output voltage, e.g. caused by an inductive load.

8 LIMITING VALUES

In accordance with the Absolute Maximum Rating System (IEC 134).

All voltages specified with respect to V_{CC} , Common.

SYMBOL	PARAMETER	CONDITIONS	MIN.	MAX.	UNIT
$-V_{EE}$	supply voltage		-	18	V
	supply current		-	15	mA
V_I	input voltage, all inputs excluding pins RMNS and PW	$I < 15\text{mA}$	$V_{EE} - 0.5$	$V_{EE} + 18$	V
V_I	input voltage, pins RMNS and PW	$I < 15\text{mA}$	$V_{EE} - 18$	$V_{EE} + 18$	V
I_I	input current, all inputs excluding pin RMNS and TRIG		-1	1	mA
$I_{RMNS(AV)}$	rectified average		-	15	mA
$I_{RMNS(RM)}$	repetitive peak		-	50	mA
I_{TRIG}	output current	$t < 300 \mu\text{s}$	-	300	mA
P_{tot}	total power dissipation		-	300	mW
T_{stg}	storage temperature		-40	+150	°C
T_{amb}	operating ambient temperature		0	+125	°C

General purpose triggering circuit

OM5428

9 CHARACTERISTICSAt $T_{amb} = 25^{\circ}\text{C}$; Voltages are specified with respect to V_{CC} , Common.

SYMBOL	PARAMETER	CONDITIONS	MIN	TYP	MAX	UNIT
Power Supply						
$-V_{EE}$	supply voltage (operating)	$I_{CC} = 1 \text{ mA}$	13.4	14.0	14.6	V
$-I_{EE}$	quiescent current	All function pins open cct	–	200	300	μA
Pulse width control input PW (pin 1)						
V_{PW}	input voltage	$I_{PW} = 100 \mu\text{A}$ $I_{PW} = -100 \mu\text{A}$	– –1.2	– –	1.2 –	V V
$I_{PW(\text{Peak})}$	input current	peak value	–	–	1	mA
t_w	pulse width	$V = 230\text{Vac}$, $R_z = 500\text{K}\Omega$	–	100	–	μs
Zero-crossing detector disable input XDIS (pin 16)						
V_{XDIS}	input voltage	inhibit	$V_{EE} + V_{BE}$	–	–	V
I_{XDIS}	input current		–	–	30	μA
Zero-crossing detector output XOUT (pin 2)						
V_{XOUT}	output voltage (pull-down)		$V_{EE} + V_{BE}$	–	–	V
I_{XOUT}	max pull down current		–	–	40	mA
Comparator input IC+ and IC– (pins 5 and 6)						
$\pm V_{ID}$	differential input voltage		–	–	7	V
I_{IC+}	input bias current	$V_{IC+} > V_{IC-} + 1\text{V}$	–	–	–10	μA
I_{IC-}	input bias current	$V_{IC-} > V_{IC+} + 1\text{V}$	–	–	–10	μA
Comparator outputs QC+ and QC– (pins 4 and 7)						
V_{QC}	output voltage	$I_{DIFFEN} = 15 \mu\text{A}$	V_{EE}	–	–	V
I_{QC}	output current (pull-down)	$I_{DIFFEN} = 15 \mu\text{A}$	–	1	–	mA
Comparator enable DIFFEN (pin 3)						
I_{DIFFEN}	enable current (pull-down)		–	15	–	μA
Sawtooth generator trigger input SAW (pin 14)						
$V_{SAW(H)}$	input trigger voltage HIGH		–	–9.0	–	V
$V_{SAW(L)}$	input trigger voltage LOW		–	–12.8	–	V
$I_{SAW(L)}$	max pull-down @ low voltage		–	50	60	μA
Sawtooth generator output FLY (pin 15)						
I_{FLY}	output current (pull-down)		–	150	225	μA
Gate sense inhibiting input SDIS (pin 8)						
I_{SDIS}	input current (pull-up)		3.0	6.0	–	μA
Output stage input AMPIN (pin 9)						
V_{AMPIN}	output drive disable (internal pull-up)	AMPIN pin open cct	–	$V_{EE} + 2V_{BE}$	–	V
I_{AMPIN}	output drive enable (pull-down)	$V_{AMPIN} = V_{EE}$	3	–	–	μA
Output stage output TRIG (pin 10)						
V_{TRIG}	output voltage	$V_{EE} = -14\text{V}$, $V_{AMPIN} = V_{EE}$	V_{EE}	–	–	V
I_{TRIG}	output current (pull-down)	$V_{sat} < 1\text{V}$	–	–	80	mA

General purpose triggering circuit

OM5428

10 IMPORTANT: ELECTRICAL SAFETY WARNING

OM5428 circuit is connected to the mains electrical supply and operates at voltages which need to be protected by proper enclosure and protective covering. Application circuits for OM5428 should be designed to conform to relevant standards (such as IEC 65, or Australian Standards AS3100, AS3250 and AS3300), it should only be used in a manner that ensures the appliance in which they are used complies with all relevant national safety and other Standards.

It is recommended that a printed circuit board using this integrated circuit be mounted with non-conductive clips, and positioned such that the minimum creepage distances from the assembly to accessible metal parts, and between high voltage points cannot be transgressed.

It should be noted that as there are Mains Voltages on the circuit board adequate labelling should be attached to warn service personnel, and others, that this danger exists.

A control board assembly should be mounted, preferably vertically, with sufficient free air flow across its surface to prevent the heat dissipated in various components from causing an unacceptable rise in the ambient temperature. The triac also needs to have an adequate heatsink, as exceeding its rated maximum junction temperature can result in loss of control, unpredictable behaviour, and possible dangerous conditions.

The board should be mounted in a place that is clean and dry at all times, not subject to condensation or the accumulation of dust and other contaminants.

11 APPLICATION INFORMATION

The reliability of modern triacs has given a strong impetus to the introduction of electronic power control in industrial as well as non-industrial areas. Because of the low cost of these devices and simplification in trigger circuitry, electronic power control now enjoys a host of applications such as electronic household cookers, panel radiators, fans, hobby tools, and even vacuum cleaners.

The general purpose trigger circuit OM5428, referred to as a trigger module, supplies the pulses for gate triggering triacs. This module is connected to the mains via a dropping resistor hence removing the need for an expensive external supply.

The OM5428 is an inexpensive, versatile trigger module and, being a monolithic IC in 16-pin dual in-line package, it takes up hardly any space at all. It is ideally suited for applications such as:

1. On/off control: static switch.
On/off control is a method of power control where triggering should preferably occur symmetrically with respect to the zero crossing of the triac current to avoid RF interference. That is, triggering must start before the current has dropped to the holding value, and must continue until the current has risen again above the latching level. Under these conditions radio interference is kept at a minimum.
2. Time proportional control: temperature and motor speed control.
Time proportional control is on/off control with a fixed repetition rate of load switching. The system is called time proportional because the power in the load averaged over the repetition period is varied. This system provides more accurate temperature control, avoiding the overshoot which is inherent in on/off control. Triggering conditions are the same as for on/off control.
3. Phase control: single phase control (full cycle).
Phase control is stepless control of output power by varying the conduction angle of the triac, 180 degree conduction corresponding to full output power. Step changes in triac voltage and current during turn-on give rise to RF interference. Appropriate RF interference suppression methods need to be applied for all phase triggered loads.
It should be noted that phase control is not permitted for heating purposes.

General purpose triggering circuit

OM5428

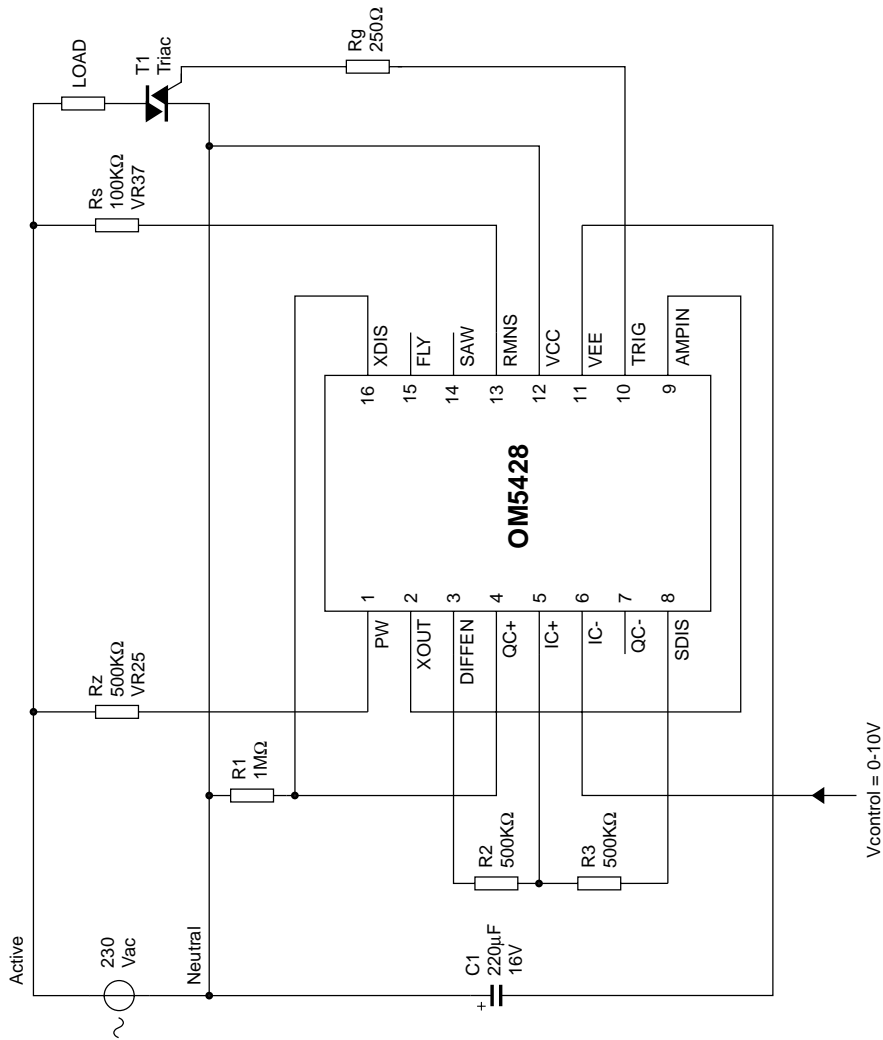

Fig.3 Typical application of the OM5428 as a static switch for resistive loads. The arrangement gives triggering around the zero crossings of the mains voltage. The values shown for Rs, Rg, Rz and C1 give a gate current $I_{GT} = 50 \text{ mA}$ typical at $V_{GT} = 1.5 \text{ V}$ and a trigger pulse duration $t_w = 100 \mu\text{s}$ typical.

General purpose triggering circuit

OM5428

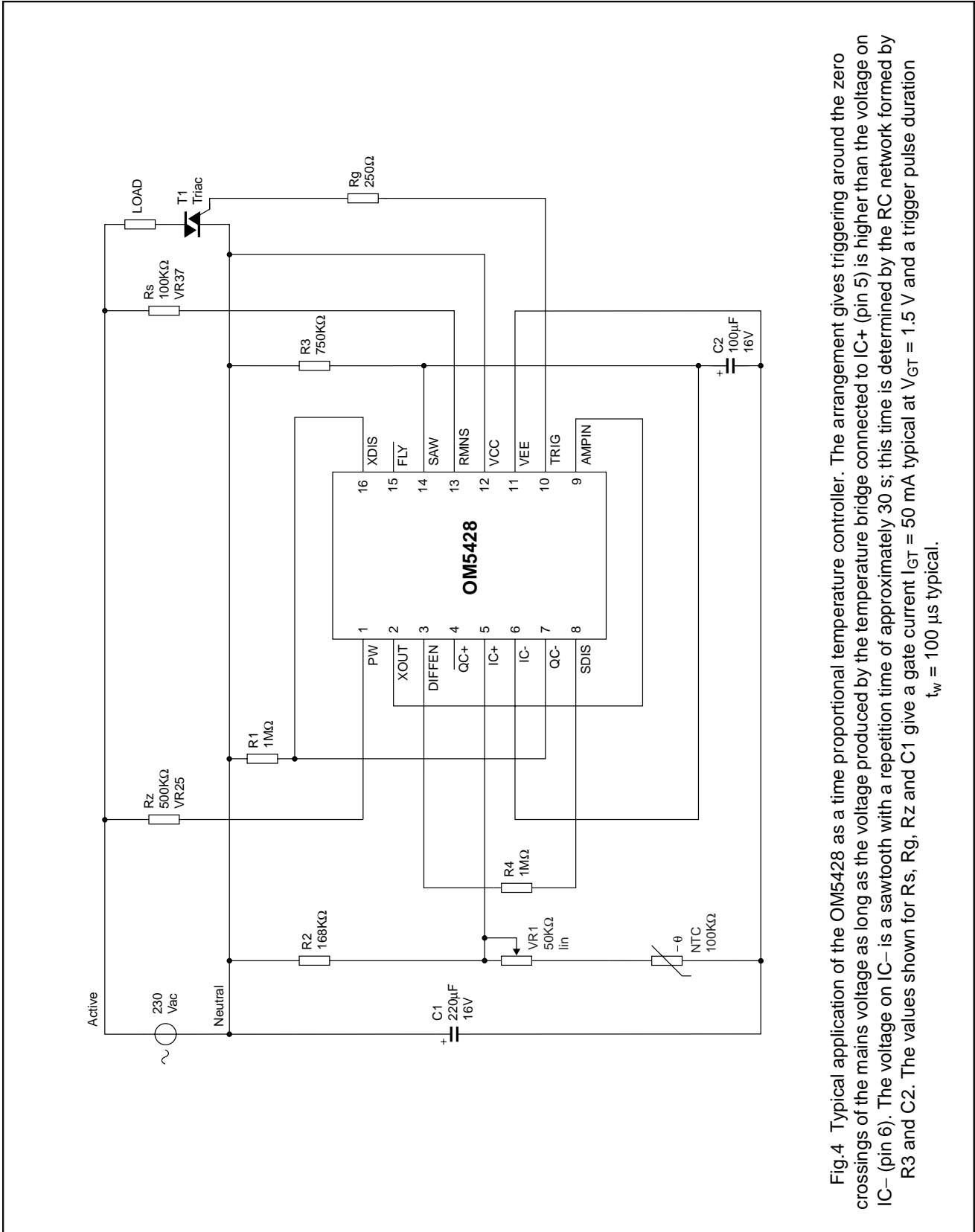

Fig.4 Typical application of the OM5428 as a time proportional temperature controller. The arrangement gives triggering around the zero crossings of the mains voltage as long as the voltage produced by the temperature bridge connected to IC+ (pin 5) is higher than the voltage on IC- (pin 6). The voltage on IC- is a sawtooth with a repetition time of approximately 30 s; this time is determined by the RC network formed by R3 and C2. The values shown for Rs, Rg, Rz and C1 give a gate current $I_{GT} = 50 \text{ mA}$ typical at $V_{GT} = 1.5 \text{ V}$ and a trigger pulse duration $t_w = 100 \mu\text{s}$ typical.

General purpose triggering circuit

OM5428

12 PACKAGE OUTLINES

DIP16: plastic dual in-line package; 16 leads (300 mil); long body

SOT38-1

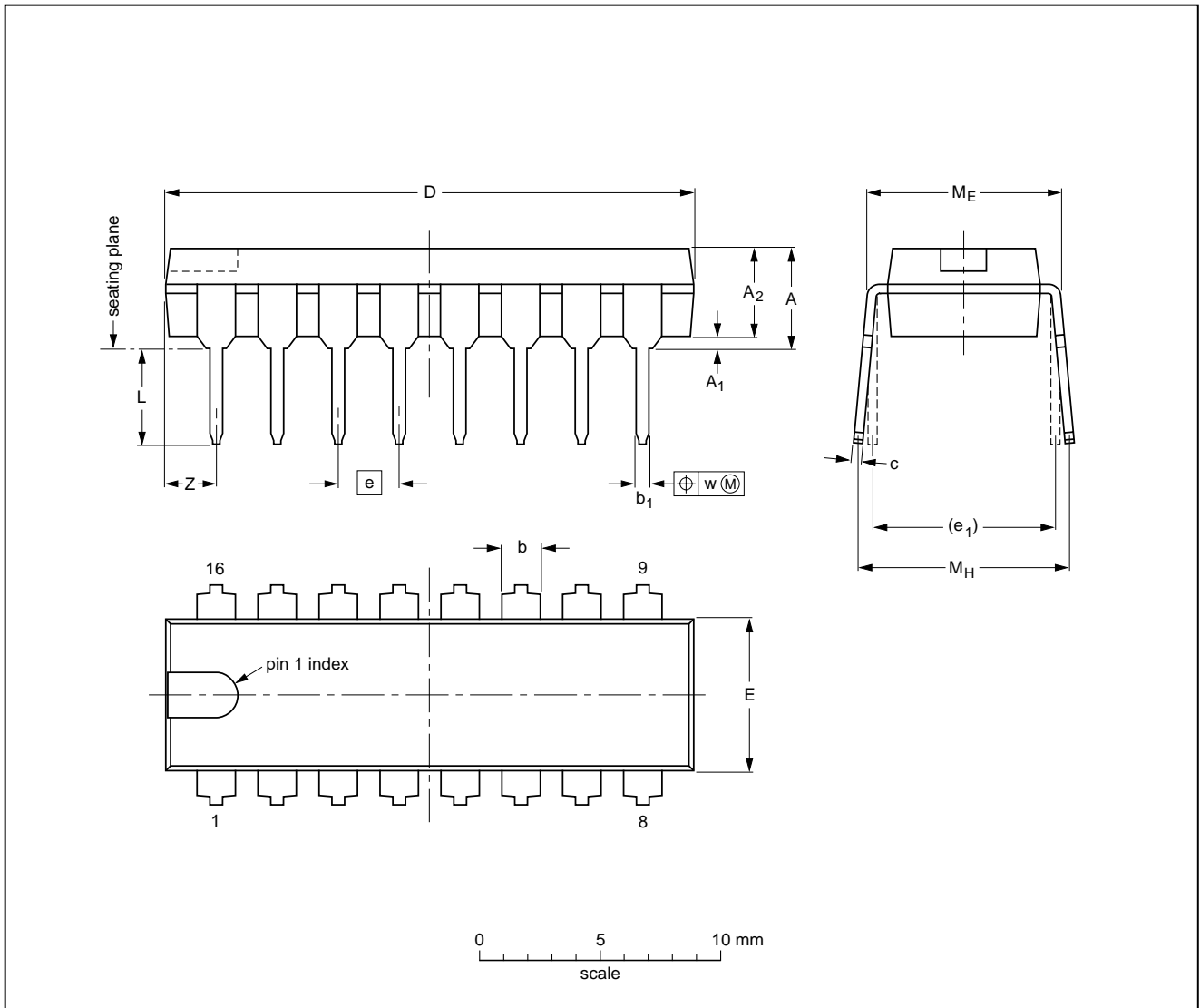

DIMENSIONS (inch dimensions are derived from the original mm dimensions)

UNIT	A max.	A ₁ min.	A ₂ max.	b	b ₁	c	D ⁽¹⁾	E ⁽¹⁾	e	e ₁	L	M _E	M _H	w	Z ⁽¹⁾ max.
mm	4.7	0.51	3.7	1.40 1.14	0.53 0.38	0.32 0.23	21.8 21.4	6.48 6.20	2.54	7.62	3.9 3.4	8.25 7.80	9.5 8.3	0.254	2.2
inches	0.19	0.020	0.15	0.055 0.045	0.021 0.015	0.013 0.009	0.86 0.84	0.26 0.24	0.10	0.30	0.15 0.13	0.32 0.31	0.37 0.33	0.01	0.087

Note

1. Plastic or metal protrusions of 0.25 mm maximum per side are not included.

OUTLINE VERSION	REFERENCES			EUROPEAN PROJECTION	ISSUE DATE
	IEC	JEDEC	EIAJ		
SOT38-1	050G09	MO-001AE			92-10-02 95-01-19

General purpose triggering circuit

OM5428

SO16: plastic small outline package; 16 leads; body width 3.9 mm

SOT109-1

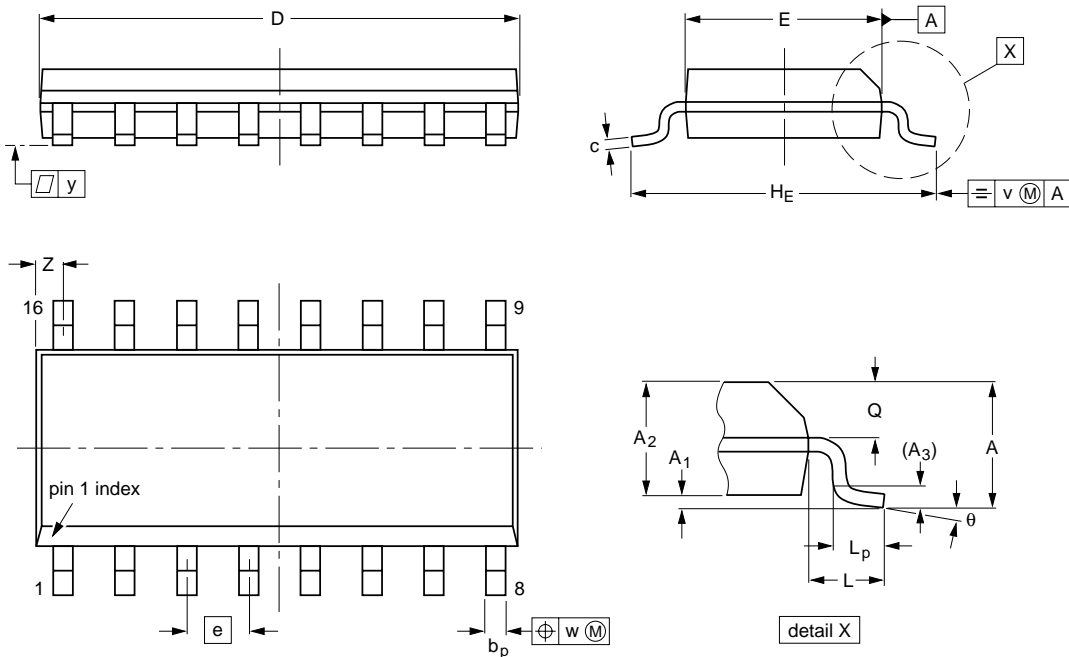

DIMENSIONS (inch dimensions are derived from the original mm dimensions)

UNIT	A max.	A ₁	A ₂	A ₃	b _p	c	D ⁽¹⁾	E ⁽¹⁾	e	H _E	L	L _p	Q	v	w	y	Z ⁽¹⁾	θ
mm	1.75	0.25 0.10	1.45 1.25	0.25	0.49 0.36	0.25 0.19	10.0 9.8	4.0 3.8	1.27	6.2 5.8	1.05	1.0 0.4	0.7 0.6	0.25	0.25	0.1	0.7 0.3	8° 0°
inches	0.069	0.010 0.004	0.057 0.049	0.01	0.019 0.014	0.0100 0.0075	0.39 0.38	0.16 0.15	0.050	0.244 0.228	0.041	0.039 0.016	0.028 0.020	0.01	0.01	0.004	0.028 0.012	

Note

1. Plastic or metal protrusions of 0.15 mm maximum per side are not included.

OUTLINE VERSION	REFERENCES			EUROPEAN PROJECTION	ISSUE DATE
	IEC	JEDEC	EIAJ		
SOT109-1	076E07S	MS-012AC			95-01-23 97-05-22

General purpose triggering circuit

OM5428

13 SOLDERING

13.1 Introduction

There is no soldering method that is ideal for all IC packages. Wave soldering is often preferred when through-hole and surface mounted components are mixed on one printed-circuit board. However, wave soldering is not always suitable for surface mounted ICs, or for printed-circuits with high population densities. In these situations reflow soldering is often used.

This text gives a very brief insight to a complex technology. A more in-depth account of soldering ICs can be found in our *"IC Package Data book"* (order code 9398 652 90011).

13.2 DIP

13.2.1 SOLDERING BY DIPPING OR BY WAVE

The maximum permissible temperature of the solder is 260 °C; solder at this temperature must not be in contact with the joint for more than 5 seconds. The total contact time of successive solder waves must not exceed 5 seconds.

The device may be mounted up to the seating plane, but the temperature of the plastic body must not exceed the specified maximum storage temperature ($T_{stg\ max}$). If the printed-circuit board has been pre-heated, forced cooling may be necessary immediately after soldering to keep the temperature within the permissible limit.

13.2.2 REPAIRING SOLDERED JOINTS

Apply a low voltage soldering iron (less than 24 V) to the lead(s) of the package, below the seating plane or not more than 2 mm above it. If the temperature of the soldering iron bit is less than 300 °C it may remain in contact for up to 10 seconds. If the bit temperature is between

300 and 400 °C, contact may be up to 5 seconds.

13.3 SO

13.3.1 REFLOW SOLDERING

Reflow soldering techniques are suitable for all SO packages.

Reflow soldering requires solder paste (a suspension of fine solder particles, flux and binding agent) to be applied to the printed-circuit board by screen printing, stencilling or pressure-syringe dispensing before package placement.

Several techniques exist for reflowing; for example, thermal conduction by heated belt. Dwell times vary between 50 and 300 seconds depending on heating method. Typical reflow temperatures range from 215 to 250 °C.

Preheating is necessary to dry the paste and evaporate the binding agent. Preheating duration: 45 minutes at 45 °C.

13.3.2 WAVE SOLDERING

Wave soldering techniques can be used for all SO packages if the following conditions are observed:

- A double-wave (a turbulent wave with high upward pressure followed by a smooth laminar wave) soldering technique should be used.
- The longitudinal axis of the package footprint must be parallel to the solder flow.
- The package footprint must incorporate solder thieves at the downstream end.

During placement and before soldering, the package must be fixed with a droplet of adhesive. The adhesive can be applied by screen printing, pin transfer or syringe

dispensing. The package can be soldered after the adhesive is cured.

Maximum permissible solder temperature is 260 °C, and maximum duration of package immersion in solder is 10 seconds, if cooled to less than 150 °C within 6 seconds. Typical dwell time is 4 seconds at 250 °C.

A mildly-activated flux will eliminate the need for removal of corrosive residues in most applications.

13.3.3 REPAIRING SOLDERED JOINTS

Fix the component by first soldering two diagonally- opposite end leads. Use only a low voltage soldering iron (less than 24 V) applied to the flat part of the lead. Contact time must be limited to 10 seconds at up to 300 °C. When using a dedicated tool, all other leads can be soldered in one operation within 2 to 5 seconds between 270 and 320 °C.

General purpose triggering circuit

OM5428

14 DEFINITIONS

Data sheet status	
Engineering sample information	This contains draft information describing an engineering sample provided to demonstrate possible function and feasibility. Engineering samples have no guarantee that they will perform as described in all details.
Objective specification	This data sheet contains target or goal specifications for product development. Engineering samples have no guarantee that they will function as described in all details.
Preliminary specification	This data sheet contains preliminary data; supplementary data may be published later. Products to this data may not yet have been fully tested, and their performance fully documented.
Product specification	This data sheet contains final product specifications.
Limiting values	
Limiting values given are in accordance with the Absolute Maximum Rating System (IEC 134). Stress above one or more of the limiting values may cause permanent damage to the device. These are stress ratings only and operation of the device at these or at any other conditions above those given in the Characteristics sections of the specification is not implied. Exposure to limiting values for extended periods may affect device reliability.	
Application information	
Where application information is given, it is advisory and does not form part of the specification.	

15 IES INFORMATION

INTEGRATED ELECTRONIC SOLUTIONS PTY. LTD.
 ABN 17 080 879 616

Postal address:

Integrated Electronic Solutions
 PO Box 2226
 Port Adelaide SA 5015
 AUSTRALIA

Street Address:

Integrated Electronic Solutions
 1 Butler Drive
 Hendon SA 5014
 AUSTRALIA

Telephone: +61 8 8348 5200
 Facsimile: +61 8 8243 1048

World Wide Web: www.ies-sa.com

Email: IES@ies.sa.com.au

General purpose triggering circuit

OM5428

16 DISCLAIMER

Integrated Electronic Solutions Pty. Ltd. ABN 17 080 879 616 ("IES") reserves the right to make changes to both its products and product data without notice.

IES makes no warranty, representation or guarantee regarding the suitability of its products for any particular purpose, nor does IES assume any liability arising out of the use or application of any IES product. IES specifically disclaims any and all liability, including without limitation incidental or consequential damages.

Typical performance figures, where quoted may depend on the application and therefore must be validated by the customer in each particular application. It is the responsibility of customers to ensure that any designs using IES products comply with good practice, applicable standards and approvals. IES accepts no responsibility for incorrect or non-compliant use of its products, failure to meet appropriate standards and approvals in the application of IES products, or for the correct engineering choice of other connected components, layout and operation of IES products.

Any customer purchasing or using IES product(s) for an unintended or unauthorised application shall indemnify and hold IES and its officers, employees, related companies, affiliates and distributors harmless against all claims, costs, damages, expenses, and reasonable legal fees arising out of, directly or indirectly, any claim of loss, personal injury or death associated with such unintended or unauthorised use, even if such claim alleges that IES was negligent regarding the design or manufacture of the relevant product(s).

Life Support Applications

Products of Integrated Electronic Solutions Pty Ltd (IES) are not designed for use in life support appliances, devices or systems, where malfunction can result in personal injury. Customers using or selling IES products for use in such applications do so at their own risk and agree to fully indemnify IES for any damages resulting from such improper use or sale.