

Product Bulletin OPB818
July 1996

Slotted Optical Switch Type OPB818

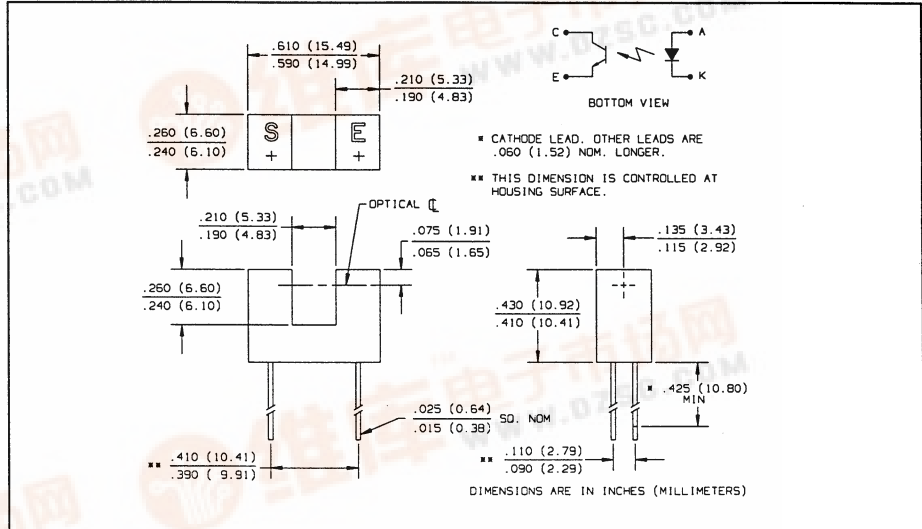
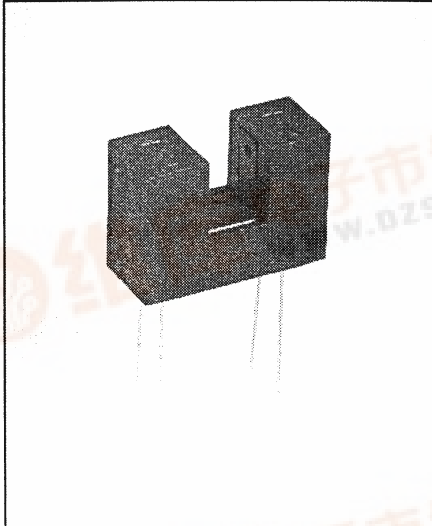

Features

- Non-contacting switching
- For direct PC board or dual-in-line socket mounting
- 0.400" (10.16 mm) lead spacing
- 0.200" (5.08 mm) wide slot

Description

The OPB818 consists of an infrared emitting diode and an NPN silicon phototransistor mounted in a low cost black plastic housing on opposite sides of a 0.200" (5.08 mm) wide slot. Phototransistor switching takes place whenever an opaque object passes through the slot. The OPB818 is designed for direct soldering into PC Boards or mounting in standard dual-in-line sockets.

Absolute Maximum Ratings (TA = 25° C unless otherwise noted)

Storage and Operating Temperature -40° C to +85° C
Lead Soldering Temperature [1/16 inch (1.6 mm) from case for 5 sec. with soldering iron] 240° C⁽¹⁾

Input Diode

Continuous Forward Current 50 mA
Peak Forward Current (1 μs pulse width, 300 pps) 3.0 A
Reverse Voltage 2.0 V
Power Dissipation 100 mW⁽²⁾

Output Phototransistor

Collector-Emitter Voltage 30 V
Emitter-Collector Voltage 5.0 V
Power Dissipation 100 mW⁽²⁾

Notes:

- (1) RMA flux is recommended. Duration can be extended to 10 sec. max when wave soldering.
- (2) Derate linearly 1.67 mW/° C above 25° C.
- (3) Methanol or isopropanol are recommended as cleaning agents. Plastic housing is soluble in chlorinated hydrocarbons and ketones.
- (4) All parameters tested using pulse technique.

Typical Performance Curves

Forward Current vs Forward Voltage Input Diode

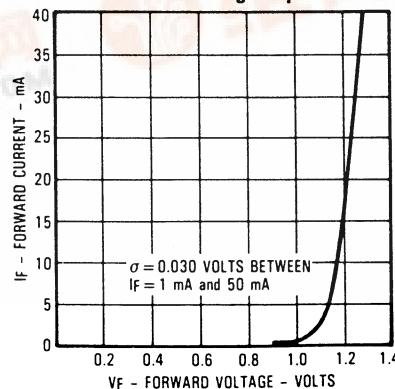

Type OPB818

Electrical Characteristics ($T_A = 25^\circ\text{C}$ unless otherwise noted)

SYMBOL	PARAMETER	MIN	MAX	UNITS	TEST CONDITIONS
Input Diode					
V_F	Forward Voltage		1.70	V	$I_F = 20\text{ mA}$
I_R	Reverse Current		100	μA	$V_R = 2\text{ V}$
Output Phototransistor					
$V_{(BR)CEO}$	Collector-Emitter Breakdown Voltage	30		V	$I_C = 1\text{ mA}$
$V_{(BR)ECO}$	Emitter-Collector Breakdown Voltage	5.0		V	$I_E = 100\ \mu\text{A}$
I_{CEO}	Collector-Emitter Dark Current		100	nA	$V_{CE} = 10\text{ V}, I_F = 0\text{ mA}, E_e = 0$
Coupled					
$V_{CE(SAT)}$	Collector-Emitter Saturation Voltage		0.40	V	$I_C = 50\ \mu\text{A}, I_F = 20\text{ mA}$
$I_{C(ON)}$	On-State Collector Current	100		μA	$V_{CE} = 10\text{ V}, I_F = 20\text{ mA}$

SLOTTED OPTICAL SWITCHES

Typical Performance Curves

Normalized Output Current vs Forward Current

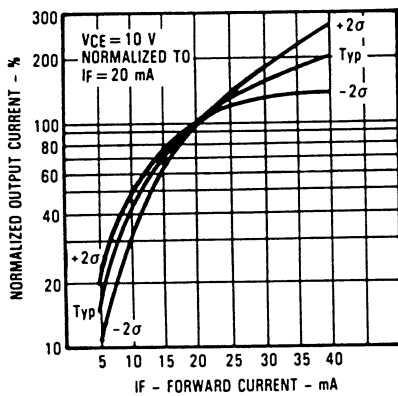

Normalized Output Current vs Ambient Temperature

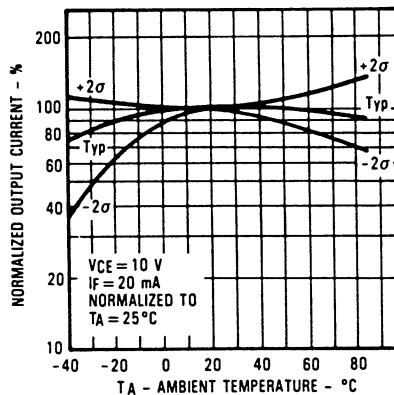

Relative Output Current vs Time

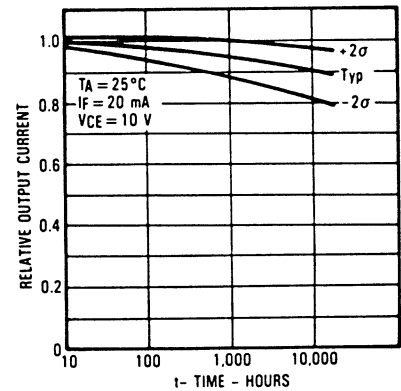

Relative Collector Dark Current vs Ambient Temperature

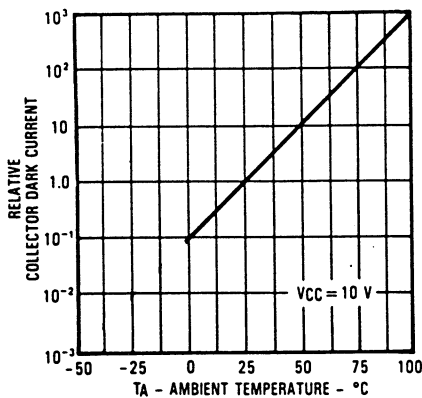

Reduction in Output Current Due to LED Heating vs Forward Current

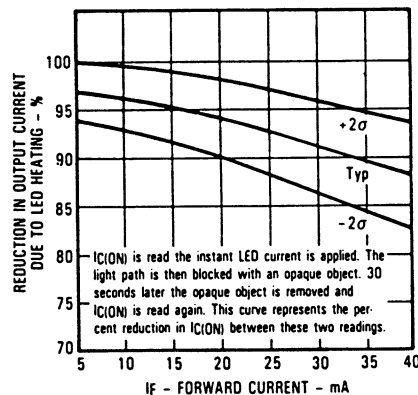

Rise and Fall Time vs Load Resistance

