

LP3936 Lighting Management System for Six White LEDs and One RGB or FLASH LED

General Description

LP3936 is a complete lighting management system designed for portable wireless applications. It contains a boost DC/DC converter, 4 white LED drivers to drive the main LCD panel backlight, 2 white LED drivers for sub-LCD panel and 1 set of RGB LED drivers.

Both WLED groups have 8-bit programmable constant current drivers that are separately adjustable and matched to 1% (typ.). For efficient backlighting the backlight intensity can be adjusted using the 8-bit ADC with ambient light detection circuit.

The RGB LED drivers are PWM-driven with programmable color, intensity and blinking patterns. In addition, they feature a FLASH function to support picture taking with camera-enabled cellular phones.

An efficient magnetic boost converter provides the required bias operating from a single Li-Ion battery. The DC/DC converter output voltage is user programmable for adapting to different LED types and for efficiency optimization. All functions are software controllable through an I²C and MicroWire/SPI compatible interface and 16 internal registers.

Features

- High Efficiency 250 mA Magnetic Boost DC-DC Converter with Programmable Output Voltage
- PWM controlled RGB LED drivers with programmable color, brightness, turn on/off slopes and blinking
- FLASH function with 3 drivers, each up to 120 mA current
- 4 constant current White LED drivers with programmable 8-bit adjustment (0 ... 25 mA/LED)
- 2 constant current White LED drivers with programmable 8-bit adjustment (0 ... 25 mA/LED)
- 8-bit ADC for ambient light sensor with averaging
- Combined MicroWire/SPI and I²C compatible serial interface
- Low current Standby mode (software controlled)
- Low voltage digital interface down to 1.8V
- Space efficient 32-pin thin CSP laminate package

Applications

- Cellular Phones
- PDAs

Typical Application

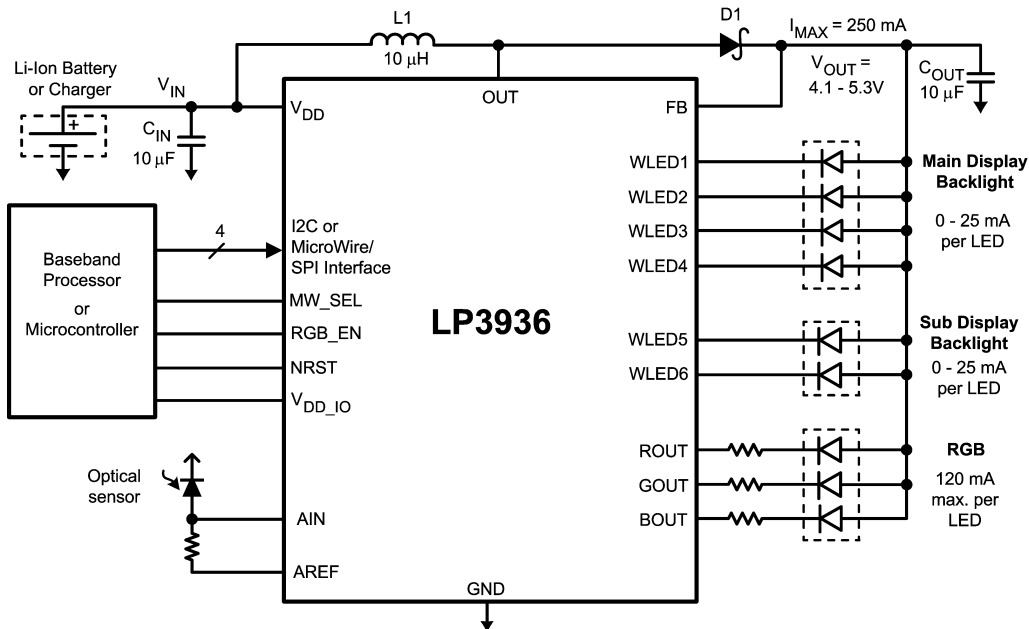

20081401

Connection Diagrams and Package Mark Information

32-Lead Thin CSP Package, 4.5 x 5.5 x 0.8 mm, 0.5 mm pitch
See NS Package Number SLD32A

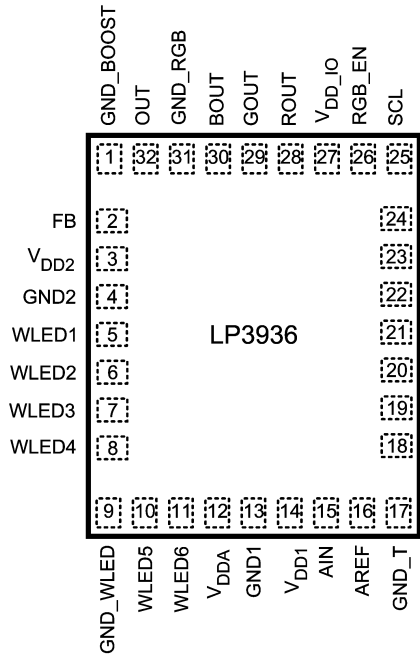

Top View

20081402

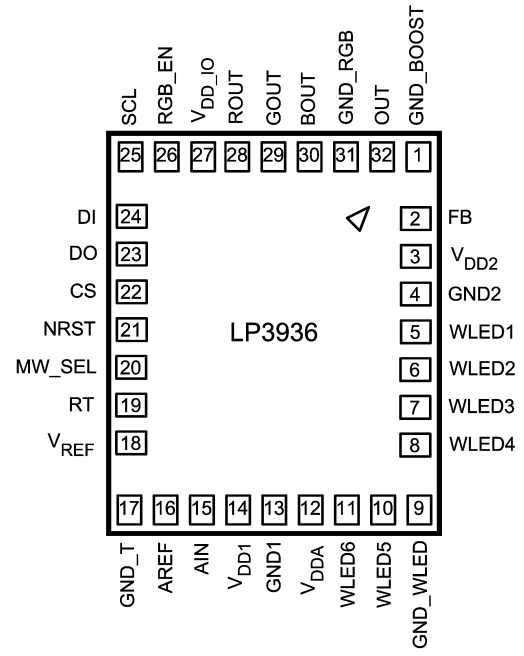

Bottom View

20081403

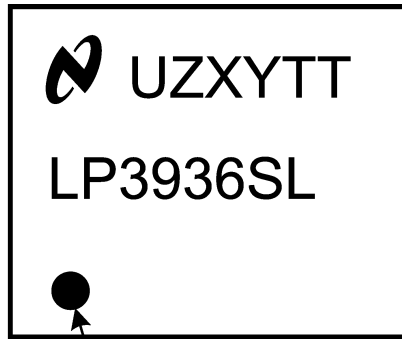

Pin 1 identifier

20081404

Note: The actual physical placement of the package marking will vary from part to part. The package marking "XY" designates the date code. "UZ" and "TT" are NSC internal codes for die manufacturing and assembly traceability. Both will vary considerably.

Package Mark — Top View

Ordering Information

Order Number	Package Marking	Supplied As
LP3936SL	LP3936SL	1000 units, Tape-and-Reel
LP3936SLX	LP3936SL	2500 units, Tape-and-Reel

Pin Description

Pin	Name	Type	Description
1	GND_BOOST	Ground	Power Switch Ground
2	FB	Input	Boost Converter Feedback
3	V _{DD2}	Power	Supply Voltage for Internal Digital Circuits
4	GND2	Ground	Ground Return for V _{DD2} (Internal Digital)
5	WLED1	LED Output	Open Drain, White LED1 Output
6	WLED2	LED Output	Open Drain, White LED2 Output
7	WLED3	LED Output	Open Drain, White LED3 Output
8	WLED4	LED Output	Open Drain, White LED4 Output
9	GND_WLED	Ground	4+2 White LED Driver Ground
10	WLED5	LED Output	Open Drain, White LED5 Output
11	WLED6	LED Output	Open Drain, White LED6 Output
12	V _{DDA}	Output	Internal LDO Output, 2.8V
13	GND1	Ground	Ground Return for V _{DD1} (Internal Analog)
14	V _{DD1}	Power	Supply Voltage for Internal Analog Circuits
15	AIN	Input	Ambient Light Sensor Input
16	AREF	Output	Reference Voltage for Ambient Light Sensor, 1.23V
17	GND_T	Ground	Ground
18	V _{REF}	Output	Internal Reference Bypass Capacitor
19	RT	Input	Oscillator Resistor
20	MW_SEL	Logic Input	MicroWire — I ² C select (MW_SEL=1 in MicroWire Mode)
21	NRST	Logic Input	Low Active Reset Input
22	CS	Logic Input/Output	MicroWire Chip-Select (in) / I ² C SDA (in/out)
23	DO	Logic Output	MicroWire Data Output
24	DI	Logic Input	MicroWire Data Input
25	SCL	Logic Input	MicroWire Clock / I ² C SCL Input
26	RGB_EN	Logic Input	LED Control for On/Off or PWM Dimming
27	V _{DD_IO}	Power	Supply Voltage for Logic IO signals
28	ROUT	LED Output	Open Drain Output, Red LED
29	GOUT	LED Output	Open Drain Output, Green LED
30	BOUT	LED Output	Open Drain Output, Blue LED
31	GND_RGB	Ground	Ground for RGB Drivers
32	OUT	Output	Open Drain, Boost Converter Power Switch

Absolute Maximum Ratings (Notes 1,

2)

If Military/Aerospace specified devices are required, please contact the National Semiconductor Sales Office/Distributors for availability and specifications.

V_{DD1} , V_{DD2} , V_{DD_IO} , $V(OUT, FB)$	-0.3V to 6.0V
Voltage on Logic Pins	-0.3V to V_{DD_IO} + 0.3V, with 6.0V max
Voltage on LED Output Pins	-0.3V to $V(FB)$ + 0.3V, with 6.0V max
Voltage on All Other Pins	-0.3V to $V_{DD1,2}$ + 0.3V, with 6.0V max
$I(ROUT, GOUT, BOUT)$	150 mA
$I(V_{REF})$	10 μ A
Continuous Power Dissipation (Note 3)	Internally Limited
Junction Temperature (T_{J_MAX})	125°C
Storage Temperature Range	-65°C to +150°C

Maximum Lead Temperature (Reflow soldering, 3 times) (Note 4)	260°C
ESD Rating (Note 5)	
Human Body Model:	2 kV
Machine Model:	200V

Operating Ratings (Notes 1, 2)

V_{DD1} , V_{DD2}	3.0V to 6.0V
V_{DD_IO}	1.8V – $V_{DD1,2}$
Recommended Load Current	0 mA to 250 mA
Junction Temperature (T_J) Range	-40°C to +125°C
Ambient Temperature (T_A) Range (Note 6)	-40°C to +85°C

Thermal Properties

Junction-to-Ambient Thermal Resistance (θ_{JA}), SLD32A Package (Note 7)	72°C/W
---	--------

Electrical Characteristics (Notes 2, 8)

Limits in standard typeface are for $T_J = 25^\circ\text{C}$. Limits in **boldface** type apply over the operating ambient temperature range (-40°C $\leq T_A \leq$ +85°C). Unless otherwise noted, specifications apply to the *Section Block Diagram* with: $V_{DD1} = V_{DD2} = V_{DD_IO} = 3.6\text{V}$, C_{VDD1} , C_{VDD2} , $C_{VDDIO} = 1\ \mu\text{F}$, C_{IN} , $C_{OUT} = 10\ \mu\text{F}$, $C_{VDDA} = 1\ \mu\text{F}$, $C_{VREF} = 0.1\ \mu\text{F}$, $L_{BOOST} = 10\ \mu\text{H}$ (Note 9).

Symbol	Parameter	Condition	Min	Typ	Max	Units
$V_{DD1,2}$	Supply Voltage		3.0	3.6	6.0	V
I_{DD}	Standby Supply Current (V_{DD1} and V_{DD2} current)	NSTBY = L (register) CS, SCL, DI, NRST = H V_{DD1} , $V_{DD2} = 3.6\text{V}$		1	7	μA
	No-Load Supply Current (V_{DD1} and V_{DD2} current, boost off)	NSTBY = H (reg.) EN_BOOST = L (reg.) SCL, CS, DI, NRST = H		170	300	μA
	Full Load Supply Current (V_{DD1} and V_{DD2} current, boost on)	NSTBY = H (register) NRST, CS, SCL, DI = H RGB_EN = L WLED1 ... 6 = L EN_AMBADC = L		1		mA
I_{DD_IO}	V_{DD_IO} Standby Supply Current	NSTBY = L (register) CS, SCL, DI, NRST = H		1		μA
	V_{DD_IO} Operating Supply Current	1 MHz Clock Frequency $C_L = 50\ \text{pF}$ at DO pin		20		μA
V_{REF}	Reference Voltage (Note 10)	$I_{REF} \leq 1\ \text{nA}$, Test Purposes Only	1.205 -2	1.23	1.255 +2	V %
V_{DDA}	LDO Output Voltage	$I_{V_{DDA}} < 1\ \mu\text{A}$	2.688 -4	2.8	2.912 +4	% V

Note 1: Absolute Maximum Ratings indicate limits beyond which damage to the component may occur. Operating Ratings are conditions under which operation of the device is guaranteed. Operating Ratings do not imply guaranteed performance limits. For guaranteed performance limits and associated test conditions, see the Electrical Characteristics tables.

Note 2: All voltages are with respect to the potential at the GND pins (GND1, GND2, GND_T, GND_BOOST, GND_WLED, GND_RGB).

Note 3: Internal thermal shutdown circuitry protects the device from permanent damage. Thermal shutdown engages at $T_J = 160^\circ\text{C}$ (typ.) and disengages at $T_J = 140^\circ\text{C}$ (typ.).

Note 4: For detailed soldering specifications and information, please refer to National Semiconductor Application Note 1125: Laminate CSP/FBGA Package (AN-1125).

Note 5: The Human body model is a 100 pF capacitor discharged through a 1.5 k Ω resistor into each pin. The machine model is a 200 pF capacitor discharged directly into each pin. MIL-STD-883 3015.7

Electrical Characteristics (Notes 2, 8) (Continued)

Note 6: In applications where high power dissipation and/or poor package thermal resistance is present, the maximum ambient temperature may have to be derated. Maximum ambient temperature (T_{A-MAX}) is dependent on the maximum operating junction temperature ($T_{J-MAX-OP} = 125^{\circ}C$), the maximum power dissipation of the device in the application (P_{D-MAX}), and the junction-to ambient thermal resistance of the part/package in the application (θ_{JA}), as given by the following equation: $T_{A-MAX} = T_{J-MAX-OP} - (\theta_{JA} \times P_{D-MAX})$.

Note 7: Junction-to-ambient thermal resistance is highly application and board-layout dependent. In applications where high maximum power dissipation exists, special care must be paid to thermal dissipation issues in board design.

Note 8: Min and Max limits are guaranteed by design, test, or statistical analysis. Typical numbers are not guaranteed, but do represent the most likely norm.

Note 9: Low-ESR Surface-Mount Ceramic Capacitors (MLCCs) are used in setting electrical characteristics.

Note 10: V_{REF} pin (Bandgap reference output) is for internal use only. A capacitor should always be placed between V_{REF} and GND1.

Block Diagram

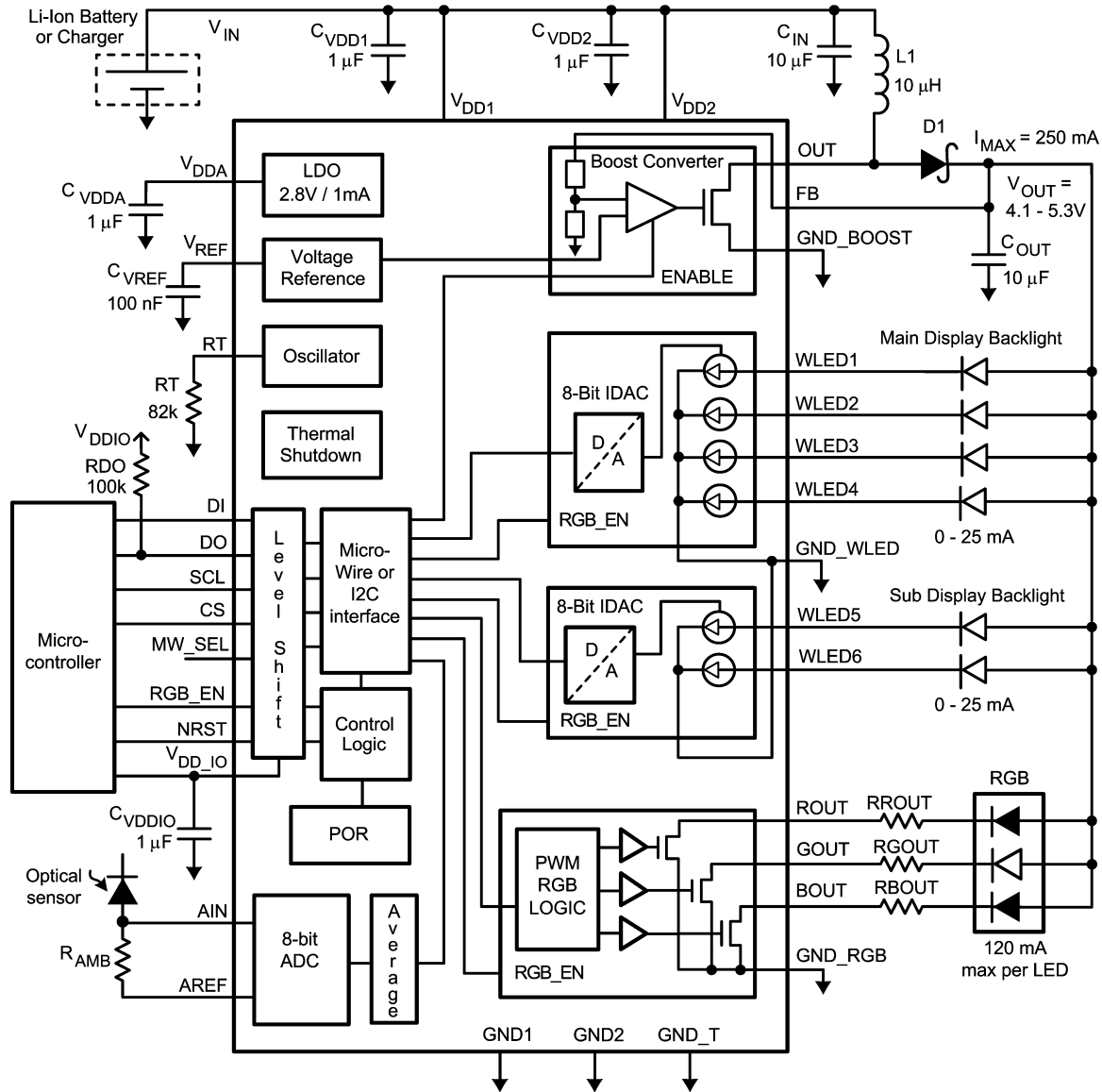

20081405

Logic Interface Characteristics

($1.8V \leq V_{DD_IO} \leq V_{DD1,2}$) (Note 11)

Symbol	Parameter	Conditions	Min	Typ	Max	Units
LOGIC INPUTS DI, SCL, NRST, RGB_EN, CS, MW_SEL						
V_{IL}	Input Low Level				0.5	V
V_{IH}	Input High Level		$V_{DD_IO} - 0.5$			V
I_I	Logic Input Current		-1.0		1.0	μA
f_{SCL}	Clock Frequency	I ² C Mode			400	kHz
		MicroWire Mode			8	MHz
LOGIC OUTPUTS DO, CS						
V_{OL}	Output Low Level	$I_{DO, CS} = 3\text{ mA}$		0.3	0.6	V
V_{OH}	Output High Level	$I_{DO} = -3\text{ mA}$	$V_{DD_IO} - 0.6$	$V_{DD_IO} - 0.3$		V
I_L	Output Leakage Current	$V_{DO} = 2.8V$			1.0	μA

Note 11: In I²C mode operating ratings are limited to $3.0V \leq V_{DD1,2} \leq 4.5V$ and $-20^\circ C \leq T_A \leq +85^\circ C$.

Control Interface

The LP3936 supports two different interfaces modes:

- 1) MicroWire/SPI interface
- 2) I²C compatible interface

User can define the interface by MW_SEL pin. The pin configuration will also change depending on which interface

is selected. The following table shows the selections for both interface modes.

MW_SEL	Interface	Pin Configuration	Comment
1	MicroWire/SPI	SCL (clock) DI (data in) DO (data out) CS (chip select)	
0	I ² C Compatible	SCL (clock) CS = SDA (data in/out)	Use pull up resistor for SCL Use pull up resistor for SDA

MicroWire/SPI Interface

The Microwire transmission consists of 16-bit Write and Read Cycles. One cycle consists of 7 Address bits, 1 Read/Write (R/W) bit and 8 Data bits. Read is done in two cycles: address is provided in the first cycle and the data is sent out on the next cycle. R/W bit high state defines a Write Cycle and low defines a Read Cycle. DO output is normally in high-impedance state and it is active only during Write and Read Cycles. A pull-up or pull-down resistor may be needed in DO line if a floating logic signal can cause unintended current consumption in other circuits where DO is connected.

The Address and Data are transmitted MSB first. The Chip Select signal CS must be low during the Cycle transmission. CS resets the interface when high and it has to be taken high between successive Cycles. Data is clocked in on the rising edge of the SCL clock signal, while data is clocked out on the falling edge of SCL.

The MicroWire interface mode can also support SPI interface. The difference with normal SPI interface is that in LP3936 the Read operation from a new address needs two read cycles. If repetitive reads are made from the same address, a correct value is obtained on every read cycle.

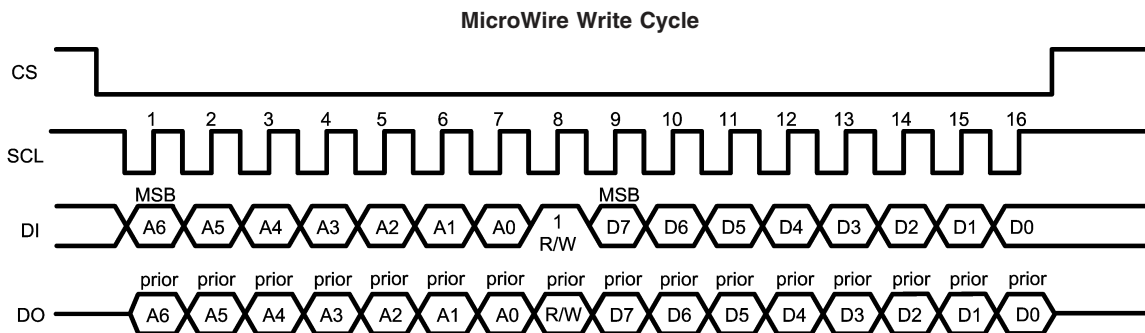

20081407

MicroWire/SPI Interface (Continued)

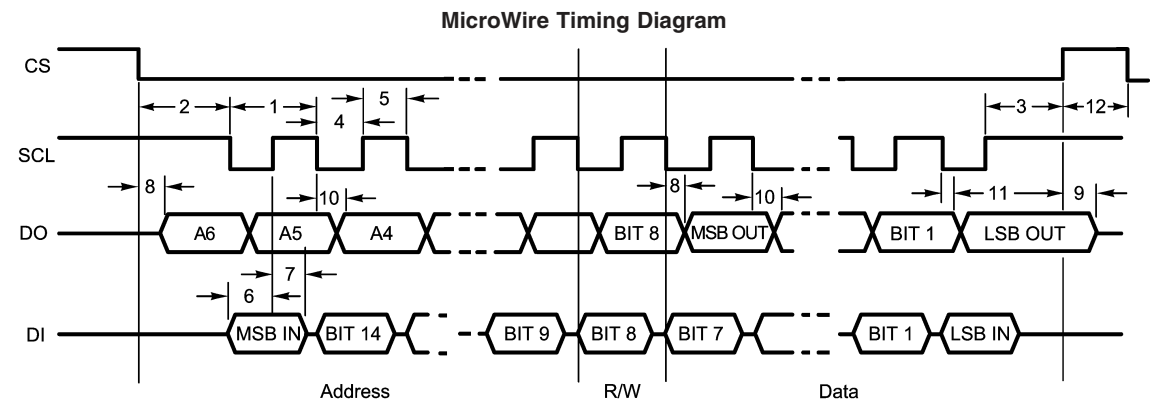
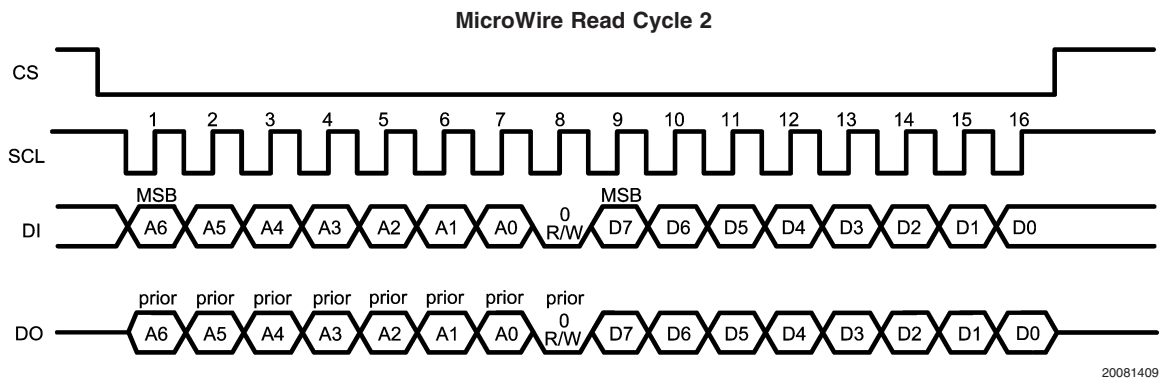
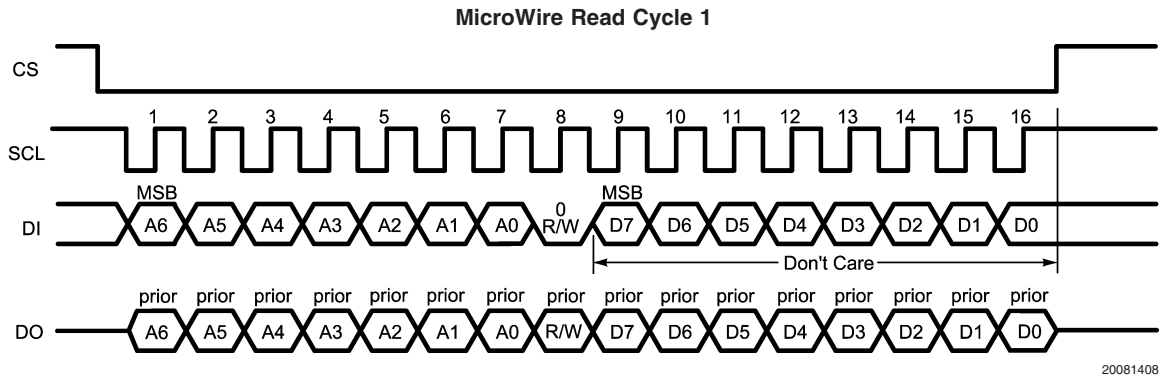

MicroWire Timing Parameters

$V_{DD1,2} = 3.0V - 6V, V_{DD,IO} = 1.8V - V_{DD1,2}$

Symbol	Parameter	Limit		Units
		Min	Max	
1	Cycle Time	120		ns
2	Enable Lead Time	60		ns
3	Enable Lag Time	60		ns
4	Clock Low Time	60		ns
5	Clock High Time	60		ns
6	Data Setup Time	0		ns
7	Data Hold Time	10		ns
8	Data Access Time		35	ns
9	Disable Time		30	ns

MicroWire Timing Parameters (Continued)

Symbol	Parameter	Limit		Units
		Min	Max	
10	Output Data Valid		55	ns
11	Output Data Hold Time	15		ns
12	CS Inactive Time	10		ns

Note: Data guaranteed by design.

I²C Compatible Interface

I²C SIGNALS

In I²C mode the LP3936 pin SCL is used for the I²C clock and the pin CS is used for the I²C data signal SDA. Both these signals need a pull-up resistor according to I²C specification. Unused pin DO can be left unconnected and pin DI must be connected to V_{DD_IO} or GND.

I²C DATA VALIDITY

The data on SDA line must be stable during the HIGH period of the clock signal (SCL). In other words, state of the data line can only be changed when CLK is LOW.

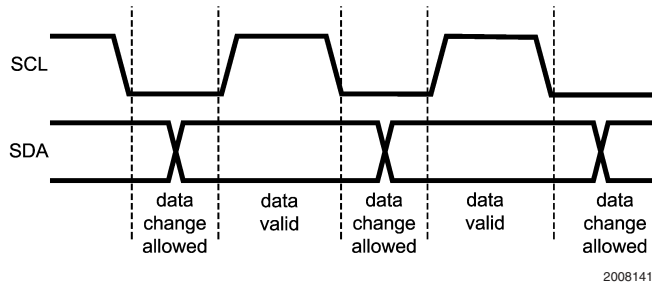

20081411

I²C START AND STOP CONDITIONS

START and STOP bits classify the beginning and the end of the I²C session. START condition is defined as SDA signal transitioning from HIGH to LOW while SCL line is HIGH. STOP condition is defined as the SDA transitioning from LOW to HIGH while SCL is HIGH. The I²C master always generates START and STOP bits. The I²C bus is considered to be busy after START condition and free after STOP condition. During data transmission, I²C master can generate repeated START conditions. First START and repeated START conditions are equivalent, function-wise.

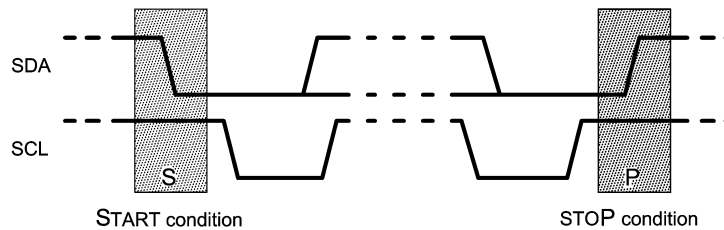

20081412

TRANSFERRING DATA

Every byte put on the SDA line must be eight bits long, with the most significant bit (MSB) being transferred first. Each byte of data has to be followed by an acknowledge bit. The acknowledge related clock pulse is generated by the master. The transmitter releases the SDA line (HIGH) during the acknowledge clock pulse. The receiver must pull down the SDA line during the 9th clock pulse, signifying an acknowledge. A receiver which has been addressed must generate an acknowledge after each byte has been received.

After the START condition, the I²C master sends a chip address. This address is seven bits long followed by an eighth bit which is a data direction bit (R/W). The LP3936 address is 36h. For the eighth bit, a "0" indicates a WRITE and a "1" indicates a READ. The second byte selects the register to which the data will be written. The third byte contains data to write to the selected register.

I²C Compatible Interface (Continued)

I²C Chip Address

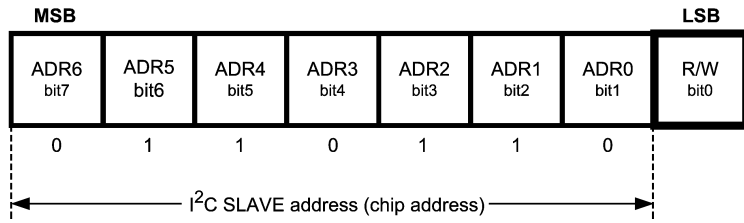

20081413

I²C Write Cycle

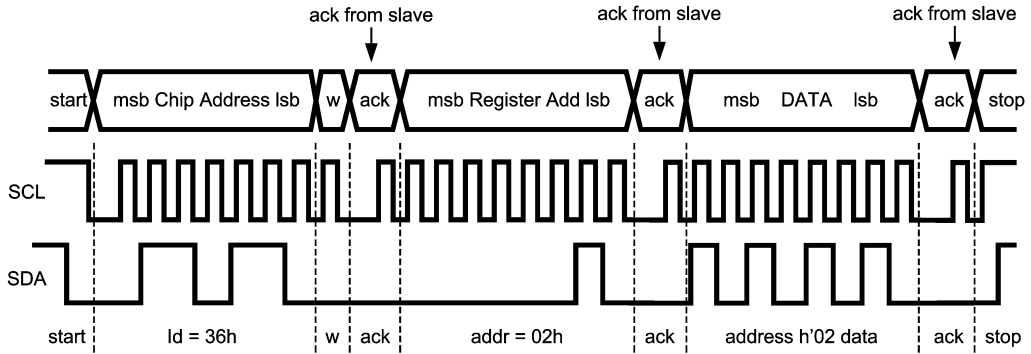

20081414

w = write (SDA = "0")
 r = read (SDA = "1")
 ack = acknowledge (SDA pulled down by either master or slave)
 rs = repeated start
 id = chip address, 36h for LP3936

When a READ function is to be accomplished, a WRITE function must precede the READ function, as shown in the Read Cycle waveform.

I²C Read Cycle

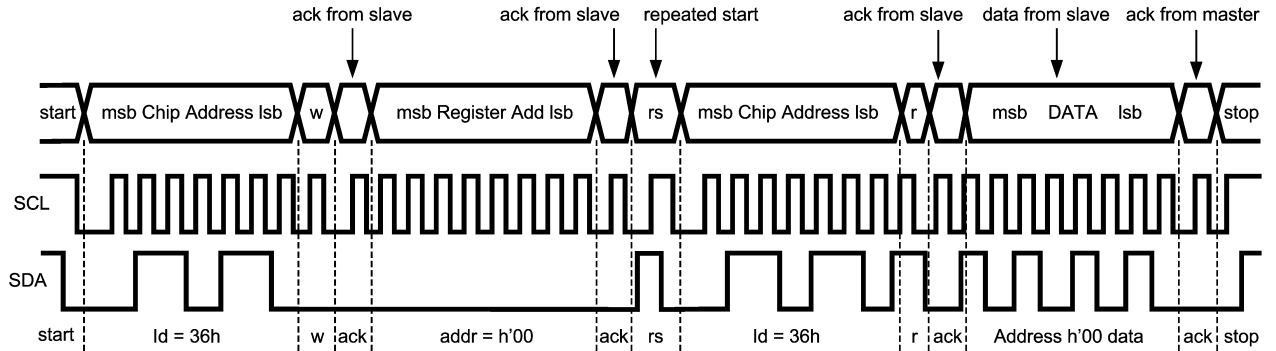

20081415

I²C Timing Diagram

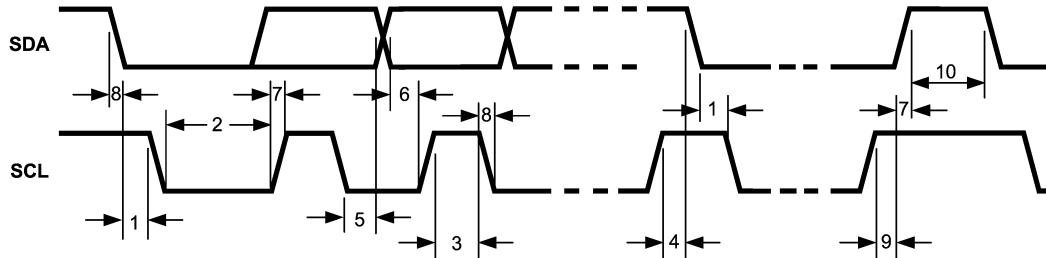

20081432

I²C Compatible Interface (Continued)

I²C Timing Parameters

$V_{DD1,2} = 3.0V$ to $4.5V$, $V_{DD_IO} = 1.8V$ to $V_{DD1,2}$

Symbol	Parameter	Limits		Units
		Min	Max	
1	Hold Time (repeated) START Condition	0.6		μs
2	Clock Low Time	1.3		μs
3	Clock High Time	600		ns
4	Setup Time for a Repeated START Condition	600		ns
5	Data Hold Time	300	900	ns
6	Data Setup Time	100		ns
7	Rise Time of SDA and SCL	$20 + 0.1C_b$	300	ns
8	Fall Time of SDA and SCL	$15 + 0.1C_b$	300	ns
9	Set-Up Time for STOP Condition	600		ns
10	Bus Free Time between a STOP and a START Condition	1.3		μs
C_b	Capacitive Load for Each Bus Line	10	200	pF

Note: Data guaranteed by design.

A/D Converter for Ambient Light Measurement

Electrical Characteristics

Symbol	Parameter	Conditions	Min	Typ	Max	Units
V_{IN_RANGE}	Input Voltage	AD Output: 00h		1.23		V
		AD Output: FFh		2.46		V
DNL	Differential Non-Linearity		-1.5	± 1	+1.5	LSB
GE	Gain Error		-5		+5	LSB
PSS	Power Supply Sensitivity	$3.1V \leq V_{DD} \leq 4.2V$		$\pm 1/2$		LSB
f(conv)	Conversion Rate	Without Averaging		217		Hz
		With Averaging (64 samples)		3.4		Hz
$t_{STARTUP}$	Startup Time			100		ms
I_{AIN}	Input Current	$1.23 < AIN < 2.6V$		± 0.1		μA
I_{AREF}	Maximum Output Current	AREF Output Current Sink		200		μA
R_{AREF}	AREF Output Resistance			110		Ω

ADC output AIN[7:0] can be read from address 0CH after startup time. Overflow bit can be read from bit D7 in address 0BH. The overflow bit indicates that input voltage exceeds the input voltage range of the ADC. The ADC output value in this case is FFH. When averaging is on, the overflow is high, if any of the 64 conversion results in the averaging period overflows. Thus the averaged result may be considerably below maximum and the overflow can still be high, if the input signal is noisy.

Examples for optical sensor are photodiode SHF2400 and phototransistor SFH3410 from Osram or BSC 3216 G1 optical sensor from TDK.

ADC can be used for temperature measurement with a thermistor. It enables temperature compensated LED driving.

If ADC is not used, it should be disabled by writing en_ambadc bit low. AIN and AREF pins can be left unconnected

A/D Converter for Ambient Light Measurement (Continued)

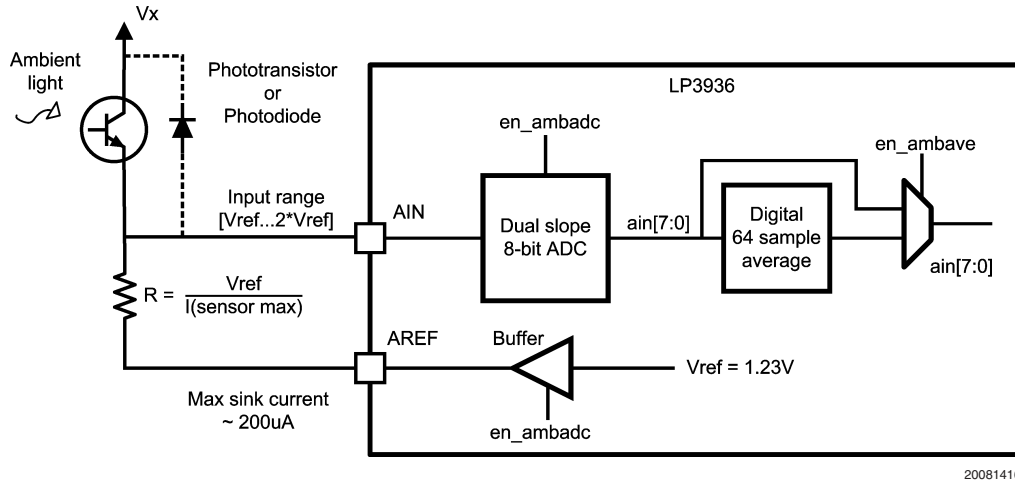

20081416

Magnetic Boost DC/DC Converter

The LP3936 Boost DC/DC Converter generates a 4.1V–5.3V supply voltage for the LEDs from single Li-Ion battery (3V ... 4.5V). The output voltage is controlled with an 8-bit register in 9 steps. The converter is a magnetic switching PFM/PWM mode DC/DC converter with a current limit. The converter has a 1 MHz switching frequency when timing resistor RT is 82 kΩ.

The topology of the magnetic boost converter is called CPM control, current programmed mode, where the inductor current is measured and controlled with the feedback. The user can program the output voltage of the boost converter. The control changes the resistor divider in the feedback loop.

The following figure shows the boost topology with the protection circuitry. Three different protection schemes are implemented:

- 1) Over voltage protection, limits the maximum output voltage
 - a. Keeps the output below breakdown voltage.
 - b. Prevents boost operation if battery voltage is much higher than desired output.
- 2) Over current protection, limits the maximum inductor current
 - a. Voltage over switching NMOS is monitored; too high voltages turn the switch off.
- 3) Duty cycle limiting, done with digital control.

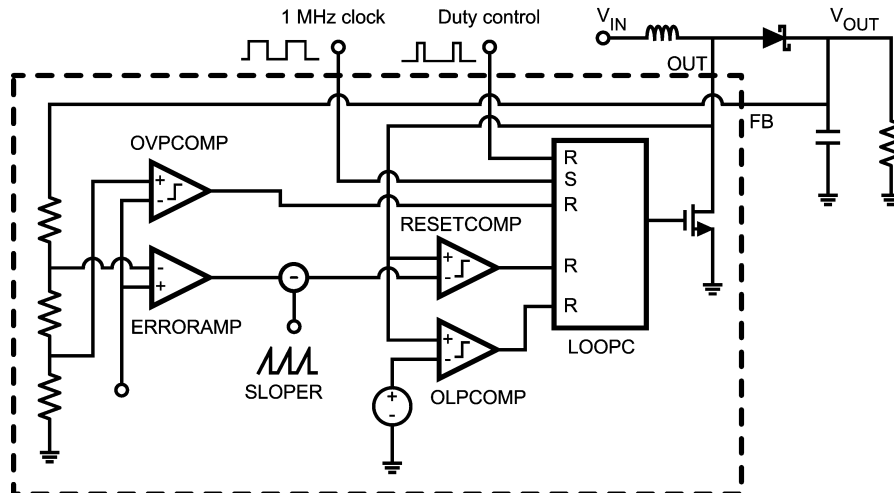

20081417

Boost Output Voltage Control

User can control the boost output voltage by boost output 8-bit register.

Boost[7:0] Register 0Dh		BOOST Output Voltage (typical)
Binary	Hex	
0000 0000	00	4.10
0000 0001	01	4.25
0000 0011	03	4.40
0000 0111	07	4.55 Default
0000 1111	0F	4.70
0001 1111	1F	4.85
0011 1111	3F	5.00
0111 1111	7F	5.15
1111 1111	FF	5.30

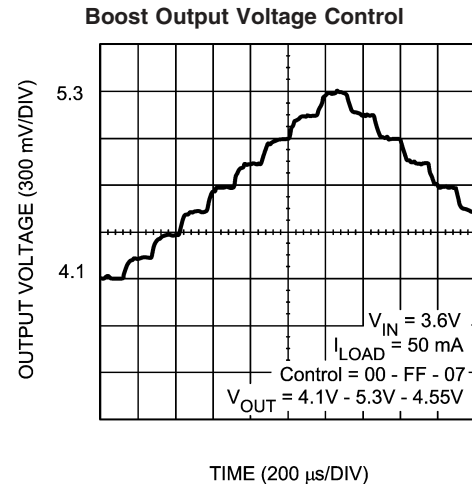

20081418

Magnetic Boost DC/DC Converter Electrical Characteristics

Symbol	Parameter	Conditions	Min	Typ	Max	Units
I_{LOAD}	Load Current	$3.0V \leq V_{IN} \leq 4.5V$ $V_{OUT} = 4.55V$	0		250	mA
V_{OUT}	Output Voltage Accuracy (FB Pin)	$1 mA \leq I_{LOAD} \leq 225 mA$ $3.0V \leq V_{IN} \leq V_{(FB)} - 0.5V$ $V_{OUT} = 4.55V$	-5		+5	%
	Output Voltage (FB Pin)	$1 mA \leq I_{LOAD} \leq 250 mA$ $3.0V < V_{IN} < 4.55V + V_{(SCHOTTKY)}$		4.55		V
		$1 mA \leq I_{LOAD} \leq 250 mA$ $V_{IN} > 4.55V + V_{(SCHOTTKY)}$		$V_{IN} - V_{(SCHOTTKY)}$		V
$R_{DS_{ON}}$	Switch ON Resistance	$V_{DD1,2} = 3.6V, I_{SW} = 0.5A$		0.4	0.5	Ω
f_{PWF}	PWM Mode Switching Frequency	$RT = 82 k\Omega$		1		MHz
	Frequency Accuracy	$RT = 82 k\Omega$	-6 -10	± 3	+6 +10	%
$t_{STARTUP}$	Startup Time			25		ms
I_{CL_OUT}	OUT Pin Current Limit	$V_{DD} = 3.6V$	600	750	1050	mA
			400		1200	

PFM/PWM Mode

User can change the Boost converters mode between PWM (Pulse Width Modulation) and PFM (Pulse Frequency Modulation). The startup is done on PFM mode and then the device runs on PWM mode (as a default). User can set PFM mode by turning "pfm_mode" register bit HIGH. PFM is recommended to use with light loads and PWM with high loads.

Boost Standby Mode

User can set boost converter to STANDBY mode by writing register bit EN_BOOST low. This mode can be useful when driving LEDs directly from battery voltage. This may be possible if LED forward voltage is low, battery voltage is high and LED current is low.

When EN_BOOST is written high, the converter starts for 10 ms in PFM mode and then goes to PWM mode if PWM mode has been selected (default).

Unused Boost Converter

If the boost converter is not used, it should be disabled by writing bit en_boost low. OUT pin should be connected to GND and FB pin to the LED supply voltage.

Boost Converter Typical Performance Characteristics $V_{IN} = 3.6V$, $V_{OUT} = 4.55V$ if not otherwise stated.

Boost Converter Efficiency

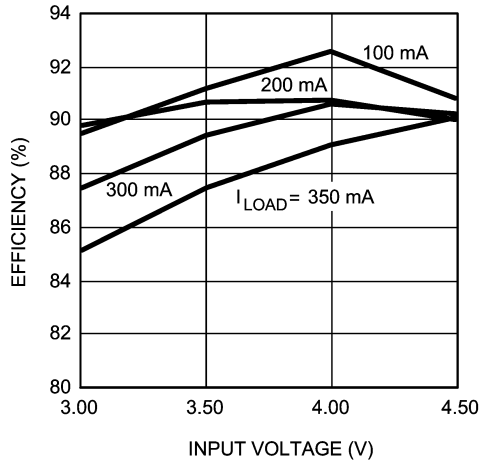

20081419

Boost Frequency vs RT Resistor

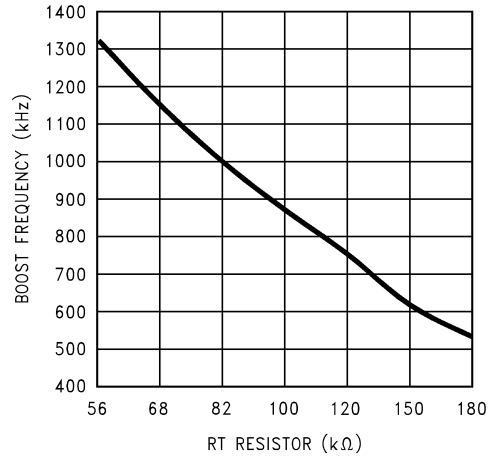

20081420

Battery Current vs Voltage

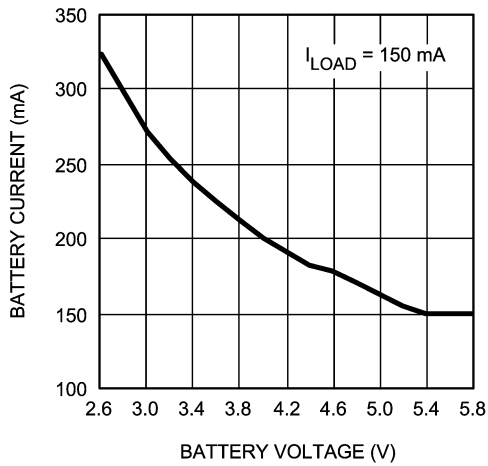

20081421

Battery Current vs Voltage

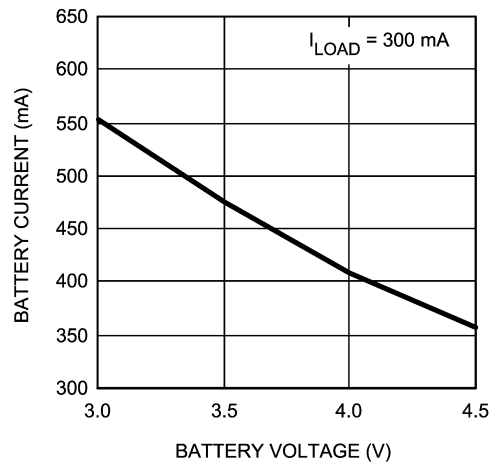

20081422

Boost Typical Waveforms at 100 mA Load

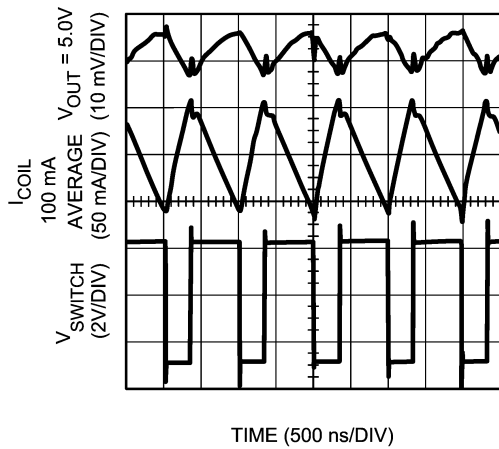

20081423

Boost Startup with No Load

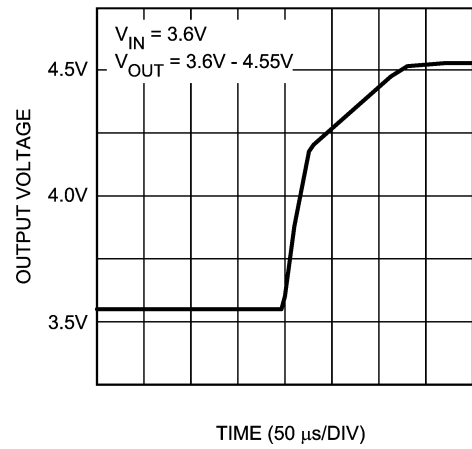

20081424

Boost Converter Typical Performance Characteristics $V_{IN} = 3.6V$, $V_{OUT} = 4.55V$ if not otherwise stated. (Continued)

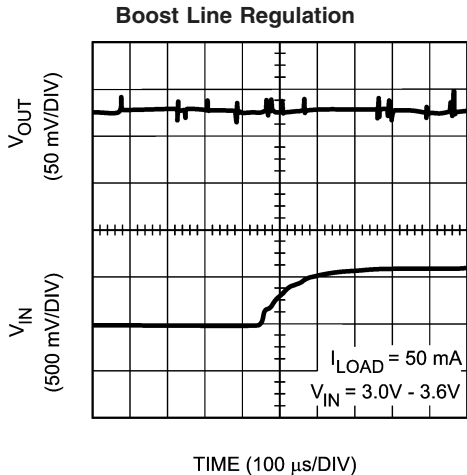

20081425

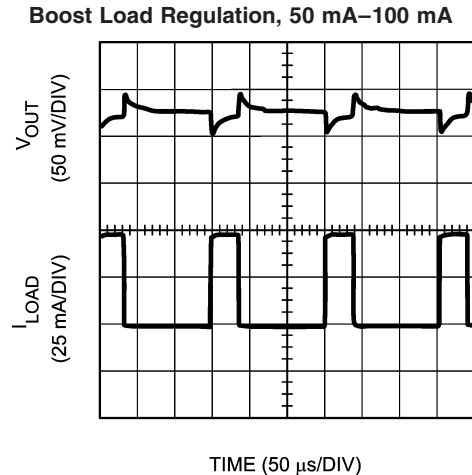

20081426

RGB LED Driver

The RGB driver has three outputs that can independently drive one RGB LED or three LEDs of any kind. User has control over the following parameters separately for each LED:

- **ON and OFF** (start and stop time in blinking cycle)

- **DUTY** (PWM brightness control)
- **SLOPE** (dimming slope)
- **ENABLE** (direct enable control)

The main blinking cycle is controlled with 2-bit CYCLE control (0.25 / 0.5 / 1.0 / 2.0s).

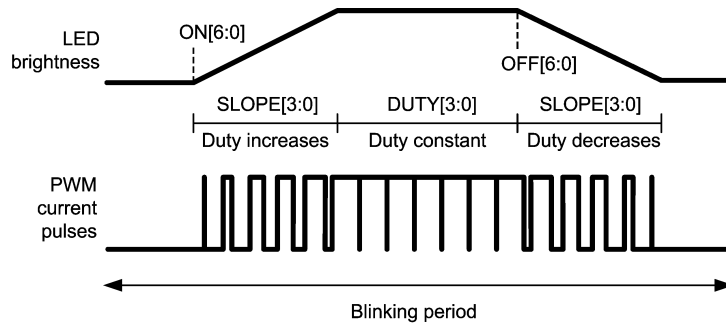

20081427

RGB PWM Operating Principle

RGB_START is the master enable control for the whole RGB function. The internal PWM and blinking control can be disabled by setting the RGB_PWM control LOW. In this case the individual enable controls can be used to switch outputs on and off. RGB_EN input can be used for external hardware PWM control. RGB_EN input can be used as direct on/off or brightness (PWM) control. If RGB_EN input is not used, it must be tied to V_{DD_IO} . Recommended maximum frequency of RGB LED external PWM control is 1 MHz.

In the normal PWM mode the R, G and B switches are controlled in 3 phases (one phase per driver). During each phase the peak current set by external resistor is driven through the LED for the time defined by DUTY setting (0 μ s–50 μ s). As a time averaged current this means 0%–33% of the peak current. The PWM period is 150 μ s and the pulse frequency is 6.67 kHz in normal mode.

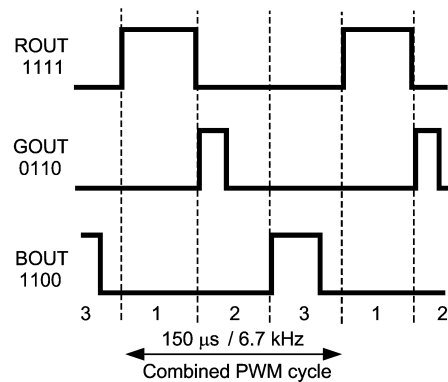

20081428

Normal Mode PWM Waveforms at different duty settings

RGB LED Driver (Continued)

In the FLASH mode all the outputs are controlled in one phase and the PWM period is 50 μ s. The time averaged FLASH mode current is three times the normal mode current at the same DUTY value.

Blinking can be controlled separately for each output. On and OFF times determine, when a LED turns on and off within the blinking cycle. When both ON and OFF are 0, the LED is on and doesn't blink. If ON equals OFF but is not 0, the LED is permanently off.

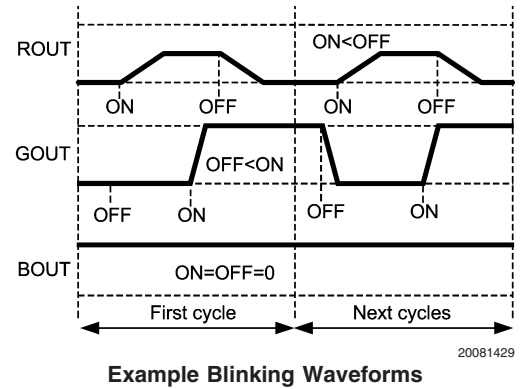

RGB Driver Electrical Characteristics

(R_{OUT} , G_{OUT} , B_{OUT} outputs)

Symbol	Parameter	Conditions	Min	Typ	Max	Units
R_{DS-ON}	ON Resistance			2	4.5	Ω
$I_{LEAKAGE}$	Off State Leakage Current	$V_{FB} = 5.3V$		0.04	1	μA
I_{MAX}	Maximum Sink Current	(Note 12)			120	mA
T_{SMAX}	Maximum Slope Period	Maximum Duty Setting		0.93		s
T_{SMIN}	Minimum Slope Period	Maximum Duty Setting		31		ms
T_{SRES}	Slope Resolution	Maximum Duty Setting		62		ms
$T_{START/STOP}$	Start/Stop Resolution	Cycle 1s		1/16		s
Duty	Duty Step Size			1/16		
T_{BLINK}	Blinking Cycle Accuracy		-6	± 3	+6	%
D_{CYCF}	Duty Cycle Range	EN_FLASH = 1	0		94	%
D_{CYC}	Duty Cycle Range	EN_FLASH = 0	0		31	%
D_{RESF}	Duty Resolution	EN_FLASH = 1 (4-bit)		6.27		%
D_{RES}	Duty Resolution	EN_FLASH = 0 (4-bit)		2.09		%
F_{PWMF}	PWM Frequency	EN_FLASH = 1		20		kHz
F_{PWM}	PWM Frequency	EN_FLASH = 0		6.67		kHz

Note 12: The total load current of the boost converter should be limited to 250 mA.

RGB LED PWM Control (Note 13)

RDUTY[3:0] GDUTY[3:0] BDUTY[3:0]	DUTY sets the brightness of the LED by adjusting the duty cycle of the PWM driver. The minimum DUTY cycle [0000] is 0% and the maximum [1111] in the Flash mode is $\sim 94\%$ and in the normal mode 31% of the peak pulse current. The peak pulse current is determined by the external resistor, LED forward voltage drop and the boost voltage.
RSLOPE[3:0] GSLOPE[3:0] BSLOPE[3:0]	SLOPE sets the turn-on and turn-off slopes. Fastest slope is set by [0000] and slowest by [1111]. SLOPE changes the duty cycle at constant, programmable rate. For each slope setting the maximum slope time appears at maximum DUTY setting. When DUTY is reduced, the slope time decreases proportionally. For example, in case of maximum DUTY, the sloping time can be adjusted from 31 ms [0000] to 930 ms [1111]. For 50% DUTY [1000] the sloping time is 17 ms [0000] to 496 ms [1111]. The blinking cycle has no effect on SLOPE.
RON[6:0] GON[6:0] BON[6:0]	ON sets the beginning time of the turn-on slope. The on-time is relative to the selected blinking cycle length. On-setting N (N = 0–127) sets the on-time to $N/128 * \text{cycle length}$.
ROFF[6:0] GOFF[6:0] BOFF[6:0]	OFF sets the beginning time of the turn-off slope. Off-time is relative to blinking cycle length in the same way as on-time.

RGB LED PWM Control (Note 13) (Continued)

	<p>If ON = 0, OFF = 0 and RGB_PWM = 1, then RGB outputs are continuously on (no blinking), DUTY controls the brightness and SLOPE is ignored.</p> <p>If ON and OFF are the same, but not 0, RGB outputs are turned off.</p>
CYCLE[1:0]	CYCLE sets the blinking cycle: [00] for 0.25s, [01] for 0.5s, [10] for 1s and [11] for 2s. CYCLE setting is common to all R, G and B drivers.
RSW GSW BSW	<p>Enable for R switch</p> <p>Enable for G switch</p> <p>Enable for B switch</p>
RGB_START	<p>Master Switch:</p> <p>RGB_START = 0 → RGB OFF</p> <p>RGB_START = 1 → RGB ON, starts the new cycle from t = 0</p>
RGB_PWM	<p>RGB_PWM = 0 → RSW, GWS and BSW control directly the RGB outputs (on/off control only)</p> <p>RGB_PWM = 1 → Normal PWM RGB functionality (duty, slope, on/off times, cycle)</p>
EN_FLASH	Flash Mode enable control for RGB. In Flash mode (EN_FLASH = 1) RGB outputs are PWM controlled simultaneously, not in 3-phase system as in the Normal Mode.
EN_RED_PWM EN_GREEN_PWM EN_BLUE_PWM	<p>EN_X_PWM = 0 → External PWM control from RGB_EN pin is disabled</p> <p>EN_X_PWM = 1 → External PWM control from RGB_EN pin is enabled</p> <p>Internal PWM control (DUTY) can be used independently of external PWM control. External PWM has the same effect on all enabled colors.</p>

Note 13: Application Note AN-1293, "Driving RGB LEDs Using LP3936 Lighting Management System" contains a thorough description of the RGB driver functionality including programming examples.

WLED Drivers

White LED drivers drive each white LED with a regulated constant current. The outputs are combined in two groups, four outputs for the main display backlight and two outputs for the sub display backlight. The current is controlled between 0 and 25.5 mA using the 8-bit current mode DA-converters. WLED outputs can be used to drive any kind of LED.

Main and sub display outputs have separate enable control bits, EN_4LED and EN_2LED.

PWM control of WLED outputs for dimming or on/off control is possible using RGB_EN pin together with EN_4LED_PWM and EN_2LED_PWM enable control bits from the user register. Recommended maximum frequency of WLED external PWM control is 1 kHz.

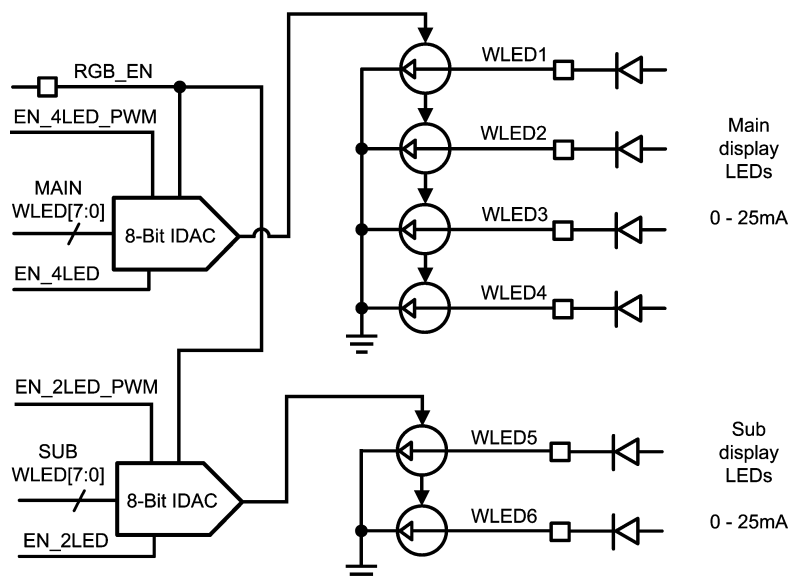

20081430

WLED and CLED Driver Electrical Characteristics

Symbol	Parameter	Conditions	Min	Typ	Max	Units
I_{RANGE}	Sink Current Range	$V_{\text{FB}} = 4.55\text{V}$, Control 00h–FFh		0–25.5		mA
I_{MAX}	Maximum Sink Current	(Note 14)	24	25.5	27	mA
			22		28	mA
I_{LEAKAGE}	Leakage Current	$V_{\text{FB}} = 5\text{V}$		0.04	1	μA
I_{MATCH}	Sink Current Matching (Note 15)	$I_{\text{SINK}} = 13\text{ mA}$, between WLED1 ... 4 or WLED5 ... 6		1.0	4	%

Note 14: A minimum voltage, Dropout Voltage, is required on the WLED outputs for maintaining the LED current. The current reduction at lower voltages is shown in the graph *WLED Output Current vs. Voltage*.

Note 15: Match % = $100\% \cdot (\text{Max} - \text{Min})/\text{Min}$

WLED Current Adjustment

WLED[7:0]	WLED Current (Typical)	Units
0000 0000	0	mA
0000 0001	0.1	mA
0000 0010	0.2	mA
0000 0011	0.3	mA
•	•	•
•	•	•
1111 1101	25.3	mA
1111 1110	25.4	mA
1111 1111	25.5	mA

WLED Output Current vs Voltage
Temperatures -40°C , $+25^\circ\text{C}$, $+85^\circ\text{C}$

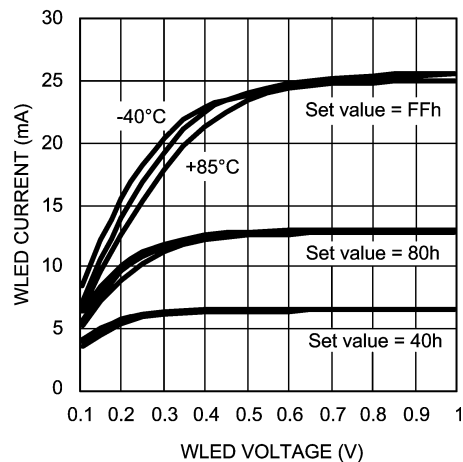

20081431

Recommended External Components

OUTPUT CAPACITOR, C_{OUT}

The output capacitor C_{OUT} directly affects the magnitude of the output ripple voltage. In general, the higher the value of C_{OUT} , the lower the output ripple magnitude. Multilayer ceramic capacitors with low ESR are the best choice. At the

lighter loads, the low ESR ceramics offer a much lower V_{OUT} ripple than the higher ESR tantalums of the same value. At the higher loads, the ceramics offer a slightly lower V_{OUT} ripple magnitude than the tantalums of the same value. However, the dv/dt of the V_{OUT} ripple with the ceramics is much lower than the tantalums under all load conditions. Capacitor voltage rating must be sufficient, 10V is recommended. It should be noted that with some capacitor types the actual capacitance depends heavily on the capacitor DC voltage bias.

INPUT CAPACITOR, C_{IN}

The input capacitor C_{IN} directly affects the magnitude of the input ripple voltage and to a lesser degree the V_{OUT} ripple. A higher value C_{IN} will give a lower V_{IN} ripple. Capacitor voltage rating must be sufficient, 10V is recommended.

OUTPUT DIODE, D_{OUT}

A Schottky diode should be used for the output diode. To maintain high efficiency the average current rating of the schottky diode should be larger than the peak inductor current (1A). Schottky diodes with a low forward drop and fast switching speeds are ideal for increasing efficiency in portable applications. Choose a reverse breakdown of the schottky diode larger than the output voltage. Do not use ordinary rectifier diodes, since slow switching speeds and long recovery times cause the efficiency and the load regulation to suffer.

INDUCTOR, L

The high switching frequency enables the use of the small surface mount inductor. A 10 μH shielded inductor is suggested. Values below 4.7 μH should not be used. The inductor should have a saturation current rating higher than the peak current it will experience during circuit operation ($\sim 1\text{A}$). Less than 300 $\text{m}\Omega$ ESR is suggested for high efficiency. Open core inductors cause flux linkage with circuit components and interfere with the normal operation of the circuit. This should be avoided. For high efficiency, choose an inductor with a high frequency core material such as ferrite to reduce the core losses. To minimize radiated noise, use a toroid, pot core or shielded core inductor. The inductor should be connected to the OUT pin as close to the IC as possible. Examples of suitable inductors are TDK types LLF4017T-100MR90C and VLF4012AT-100MR79 and Coilcraft type DO3314T-103 (unshielded).

Recommended External Components (Continued)

List of Recommended External Components

Symbol	Symbol Explanation	Value	Unit	Type
C _{VDD1}	V _{DD1} bypass capacitor	1	μF	Ceramic, X7R
C _{VDD2}	V _{DD2} bypass capacitor	1	μF	Ceramic, X7R
C _{OUT}	Output capacitor from FB to GND	10	μF	Ceramic, X7R/Y5V
C _{IN}	Input capacitor from Battery Voltage to GND	10	μF	Ceramic, X7R/Y5V
C _{VDDIO}	V _{DDIO} bypass capacitor	1	μF	Ceramic, X7R
C _{VDDA}	Internal LDO output capacitor, between V _{DDA} and GND	1	μF	Ceramic, X7R
RT	Oscillator Frequency Bias Resistor	82	kΩ	1% (Note 16)
RDO	DO output pull-up resistor	100	kΩ	
C _{VREF}	Reference Voltage Capacitor, between V _{REF} and GND	100	nF	Ceramic, X7R
L _{BOOST}	Boost converter inductor	10	μH	Shielded, Low ESR, I _{SAT} ~1A
D _{OUT}	Rectifying Diode, V _F @ Maxload	0.3	V	Schottky Diode
RGB	RGB LED	User Defined (See Application Note AN-1293 for resistor size calculation)		
R _R , R _G , R _B	Current Limit Resistors			
LEDs	White LEDs			

Note 16: Resistor RT tolerance change will change the timing accuracy of the RGB block. Also the boost converter switching frequency will be affected.

Control Registers

All user accessible control registers and register bits are shown in the following table.

ADDR	SETUP	D7	D6	D5	D4	D3	D2	D1	D0
00H	Control register	rgb_pwm	rgb_start	cycle[1]	cycle[0]	rsw	gsw	bsw	pfm_mode
01H	ron		ron[6]	ron[5]	ron[4]	ron[3]	ron[2]	ron[1]	ron[0]
02H	roff		roff[6]	roff[5]	roff[4]	roff[3]	roff[2]	roff[1]	roff[0]
03H	gon		gon[6]	gon[5]	gon[4]	gon[3]	gon[2]	gon[1]	gon[0]
04H	goff		goff[6]	goff[5]	goff[4]	goff[3]	goff[2]	goff[1]	goff[0]
05H	bon		bon[6]	bon[5]	bon[4]	bon[3]	bon[2]	bon[1]	bon[0]
06H	boff		boff[6]	boff[5]	boff[4]	boff[3]	boff[2]	boff[1]	boff[0]
07H	rslope, rduty	rslope[3]	rslope[2]	rslope[1]	rslope[0]	rduty[3]	rduty[2]	rduty[1]	rduty[0]
08H	gslope, gduty	gslope[3]	gslope[2]	gslope[1]	gslope[0]	gduty[3]	gduty[2]	gduty[1]	gduty[0]
09H	bslope, bduty	bslope[3]	bslope[2]	bslope[1]	bslope[0]	bduty[3]	bduty[2]	bduty[1]	bduty[0]
0AH	wled current 1	wled1[7]	wled1[6]	wled1[5]	wled1[4]	wled1[3]	wled1[2]	wled1[1]	wled1[0]
0BH	enables	overflow	nstby	en_boost	en_flash	en_ambave	en_ambadc	en_4led	en_2led
0CH	Amb. Light data	ain[7]	ain[6]	ain[5]	ain[4]	ain[3]	ain[2]	ain[1]	ain[0]
0DH	boost output	boost[7]	boost[6]	boost[5]	boost[4]	boost[3]	boost[2]	boost[1]	boost[0]
2AH	wled current 2	wled2[7]	wled2[6]	wled2[5]	wled2[4]	wled2[3]	wled2[2]	wled2[1]	wled2[0]
2BH	ext pwm enable				en_redpwm	en_greenpwm	en_bluepwm	en_4ledpwm	en_2ledpwm

Default value of each register is 0000 0000 except the following

- boost output default is 0000 0111 = 07h (4.55V).
- enables default is x010 0000 = 20h (boost enabled)
- ext_pwm_enable default is 0001 1100 = 1Ch (RGB_EN control enabled for color outputs)

Register 0Ch all bits (ain[7:0]) and bit D7 in register 0Bh (overflow) are read only. All other bits are read-write.

Physical Dimensions inches (millimeters) unless otherwise noted

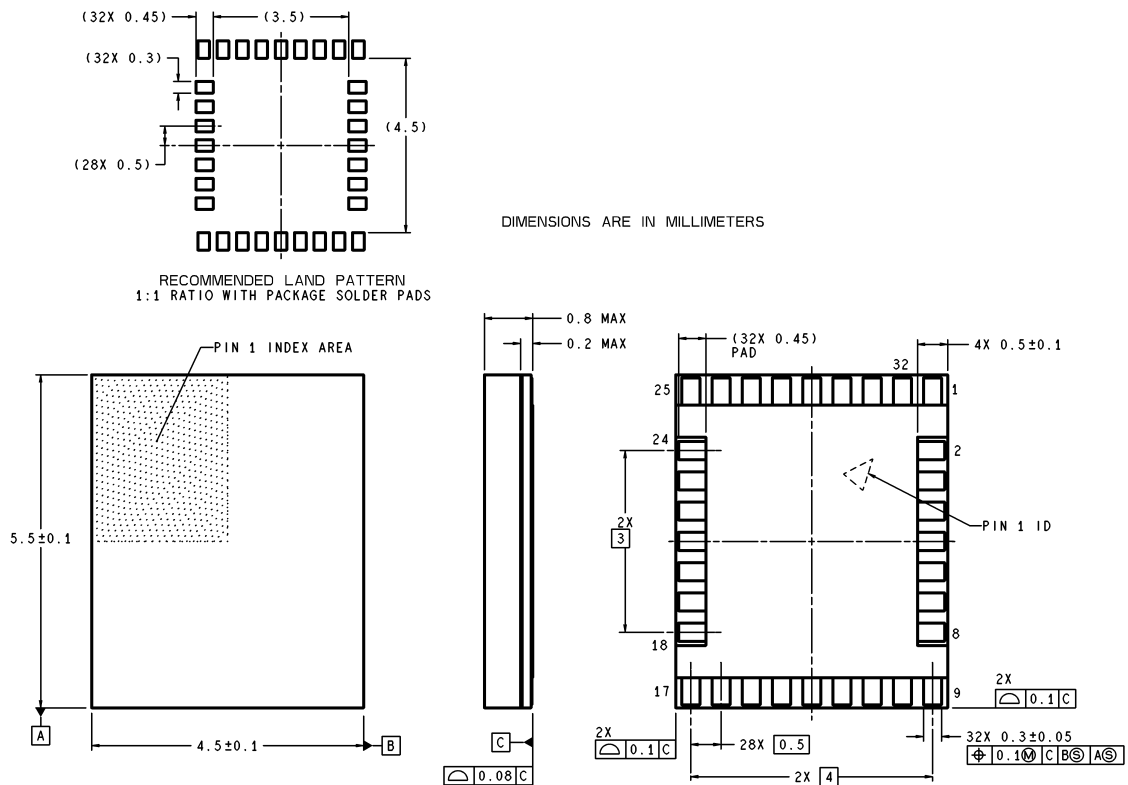

**32-Lead Thin CSP Package, 4.5 x 5.5 x 0.8 mm, 0.5 mm Pitch
NS Package Number SLD32A**

SLD32A (Rev A)

LIFE SUPPORT POLICY

NATIONAL'S PRODUCTS ARE NOT AUTHORIZED FOR USE AS CRITICAL COMPONENTS IN LIFE SUPPORT DEVICES OR SYSTEMS WITHOUT THE EXPRESS WRITTEN APPROVAL OF THE PRESIDENT AND GENERAL COUNSEL OF NATIONAL SEMICONDUCTOR CORPORATION. As used herein:

1. Life support devices or systems are devices or systems which, (a) are intended for surgical implant into the body, or (b) support or sustain life, and whose failure to perform when properly used in accordance with instructions for use provided in the labeling, can be reasonably expected to result in a significant injury to the user.
2. A critical component is any component of a life support device or system whose failure to perform can be reasonably expected to cause the failure of the life support device or system, or to affect its safety or effectiveness.

BANNED SUBSTANCE COMPLIANCE

National Semiconductor certifies that the products and packing materials meet the provisions of the Customer Products Stewardship Specification (CSP-9-111C2) and the Banned Substances and Materials of Interest Specification (CSP-9-111S2) and contain no "Banned Substances" as defined in CSP-9-111S2.



National Semiconductor
Americas Customer Support Center
Email: new.feedback@nsc.com
Tel: 1-800-272-9959

National Semiconductor
Europe Customer Support Center
Fax: +49 (0) 180-530 85 86
Email: europe.support@nsc.com
Deutsch Tel: +49 (0) 69 9508 6208
English Tel: +44 (0) 870 24 0 2171
Français Tel: +33 (0) 1 41 91 8790

National Semiconductor
Asia Pacific Customer Support Center
Email: ap.support@nsc.com

National Semiconductor
Japan Customer Support Center
Fax: 81-3-5639-7507
Email: jpn.feedback@nsc.com
Tel: 81-3-5639-7560

www.national.com

Copyright © Each Manufacturing Company.

All Datasheets cannot be modified without permission.

This datasheet has been download from :

www.AllDataSheet.com

100% Free DataSheet Search Site.

Free Download.

No Register.

Fast Search System.

www.AllDataSheet.com