



HIGH VOLTAGE POWER OPERATIONAL AMPLIFIERS

PA88 • PA88A

HTTP://WWW.APEXMICROTECH.COM (800) 546-APEX (800) 546-2739

FEATURES

- HIGH VOLTAGE — 450V (±225V)
- LOW QUIESCENT CURRENT — 2mA
- HIGH OUTPUT CURRENT — 100mA
- PROGRAMMABLE CURRENT LIMIT
- LOW BIAS CURRENT — FET Input

APPLICATIONS

- PIEZOELECTRIC POSITIONING
- HIGH VOLTAGE INSTRUMENTATION
- ELECTROSTATIC TRANSDUCERS
- PROGRAMMABLE POWER SUPPLIES UP TO 440V

DESCRIPTION

The PA88 is a high voltage, low quiescent current MOSFET operational amplifier designed for output currents up to 100mA. Output voltages can swing up to ±215V with a dual supply and up to +440 volts with a single supply. The safe operating area (SOA) has no second breakdown limitations and can be observed with all types of loads by choosing an appropriate current limiting resistor. High accuracy is achieved with a cascode input circuit configuration. All internal biasing is referenced to a bootstrapped zener-MOSFET current source. As a result, the PA88 features an unprecedented supply range and excellent supply rejection. The MOSFET output stage is biased on for linear operation. External compensation provides user flexibility.

This hybrid circuit utilizes beryllia (BeO) substrates, thick film resistors, ceramic capacitors and semiconductor chips to maximize reliability, minimize size and give top performance. Ultrasonically bonded aluminum wires provide reliable interconnections at all operating temperatures. The 8-pin TO-3 package is hermetically sealed and electrically isolated. The use of compressible thermal isolation washers and/or improper mounting torque will void the product warranty. Please see "General Operating Considerations".

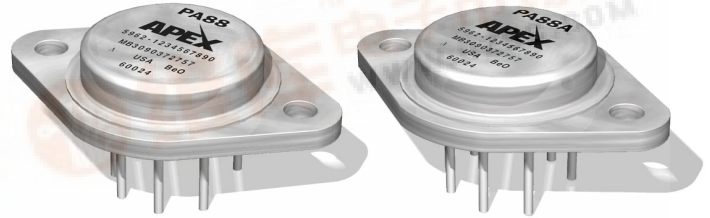

PATENTED

TYPICAL APPLICATION

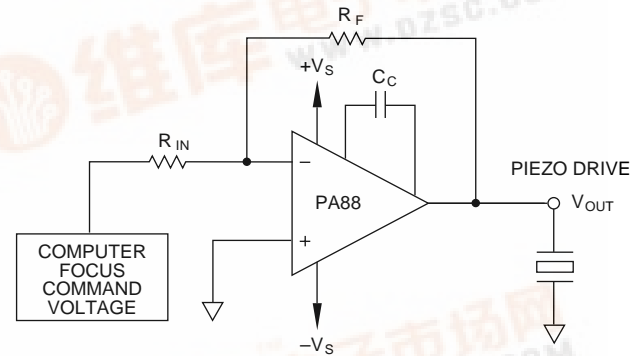

LOWPOWER,PIEZOELECTRICPOSITIONING

Piezo positioning may be applied to the focusing of segmented mirror systems. The composite mirror may be composed of hundreds of elements, each requiring focusing under computer control. In such complex systems the PA88's advantage of low quiescent power consumption reduces the costs of power supplies and cooling, while providing the interface between the computer and the high voltage drive to the piezo positioners.

EQUIVALENT SCHEMATIC

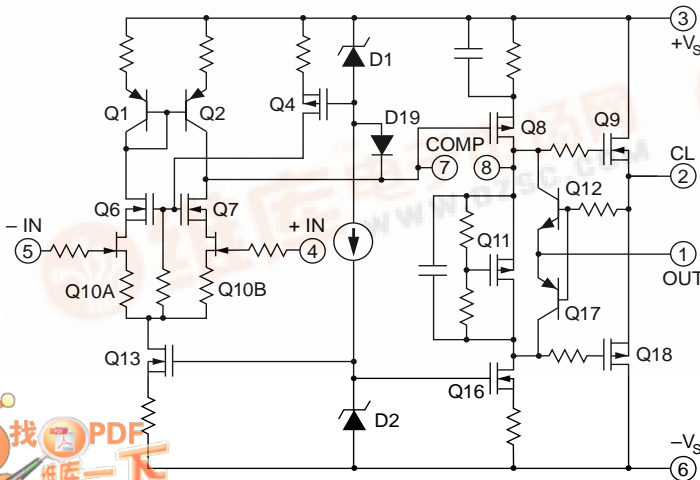

EXTERNAL CONNECTIONS

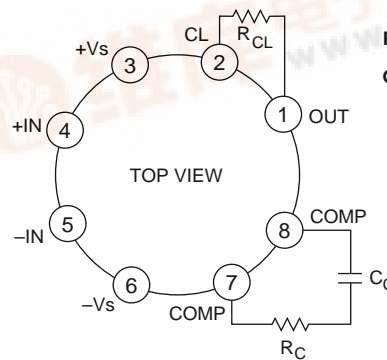

PHASE COMPENSATION

GAIN	C _C	R _C
1	68pf	100 Ω
10	33pf	100 Ω
20	15pf	100 Ω
100	3.3pf	—

$$R_{CL} = \frac{.7}{I_{LIM}}$$

C_C RATED FOR FULL SUPPLY VOLTAGE

PA88 • PA88A

ABSOLUTE MAXIMUM RATINGS SPECIFICATIONS

ABSOLUTE MAXIMUM RATINGS

SUPPLY VOLTAGE, +V _S to -V _S	450V
OUTPUT CURRENT, source, sink	See SOA
POWER DISSIPATION, continuous @ T _C = 25°C	15W
INPUT VOLTAGE, differential	±25V
INPUT VOLTAGE, common mode	±V _S
TEMPERATURE, pin solder - 10s max	300°C
TEMPERATURE, junction ²	150°C
TEMPERATURE, storage	-65 to +150°C
OPERATING TEMPERATURE RANGE, case	-55 to +125°C

SPECIFICATIONS

PARAMETER	TEST CONDITIONS ¹	PA88			PA88A			UNITS	
		MIN	TYP	MAX	MIN	TYP	MAX		
INPUT									
OFFSET VOLTAGE, initial	Full temperature range		.5	2		.25	.5	mV	
OFFSET VOLTAGE, vs. temperature			10	30		5	10	μV/°C	
OFFSET VOLTAGE, vs. supply			1	5		*	*	μV/V	
OFFSET VOLTAGE, vs. time				75		*	*	μV/√kh	
BIAS CURRENT, initial ³				5	50		3	10	pA
BIAS CURRENT, vs. supply				.01			*		pA/V
OFFSET CURRENT, initial ³				2.5	100		3	20	pA
INPUT IMPEDANCE, DC				10 ¹¹			*		Ω
INPUT CAPACITANCE				4			*		pF
COMMON MODE VOLTAGE RANGE ⁴			±V _S -12			*			V
COMMON MODE REJECTION, DC	V _{CM} = ±90V	90	110		*	*		dB	
NOISE	100kHz BW, R _S = 1KΩ, C _C = 15pf		2			*		μVrms	
GAIN									
OPEN LOOP, @ 15Hz	R _L = 2KΩ, C _C = OPEN	96	111		*	*		dB	
GAIN BANDWIDTH PRODUCT at 1MHz	R _L = 2KΩ, C _C = 15pf, R _C = 100Ω		2.1			*		MHz	
POWER BANDWIDTH	R _L = 2KΩ, C _C = 15pf, R _C = 100Ω		6			*		kHz	
PHASE MARGIN	Full temperature range		60			*		°	
OUTPUT									
VOLTAGE SWING ⁴	I _O = ±100mA	±V _S -12	±V _S -9.8		*	*		V	
VOLTAGE SWING ⁴	Full temp. range, I _O = ±75mA	±V _S -8.5	±V _S -7.5		*	*		V	
VOLTAGE SWING ⁴	Full temp. range, I _O = ±20mA	±V _S -8.0	±V _S -5.2		*	*		V	
CURRENT, continuous	T _C = 85°C	±100				*		mA	
SLEW RATE, A _V = 20	C _C = 15pf, R _C = 100Ω		8			*		V/μs	
SLEW RATE, A _V = 100	C _C = OPEN		30			*		V/μs	
CAPACITIVE LOAD, A _V = +1	Full temperature range	470			*			pf	
SETTLING TIME to .1%	C _C = 15pf, R _C = 100Ω, 2V step		10			*		μs	
RESISTANCE, no load	R _{CL} = 0		100			*		Ω	
POWER SUPPLY									
VOLTAGE ⁶	See note 6	±15	±200	±225	*	*	*	V	
CURRENT, quiescent,			1.7	2		*	*	mA	
THERMAL									
RESISTANCE, AC, junction to case ⁵	Full temperature range, F > 60Hz			5.0		*	*	°C/W	
RESISTANCE, DC, junction to case	Full temperature range, F < 60Hz			8.3		*	*	°C/W	
RESISTANCE, junction to air	Full temperature range		30			*	*	°C/W	
TEMPERATURE RANGE, case	Meets full range specifications	-25		+85	*		*	°C	

NOTES: * The specification of PA88A is identical to the specification for PA88 in applicable column to the left.

- Unless otherwise noted: T_C = 25°C, compensation = C_C = 68pF, R_C = 100Ω. DC input specifications are ± value given. Power supply voltage is typical rating.
- Long term operation at the maximum junction temperature will result in reduced product life. Derate internal power dissipation to achieve high MTTF.
- Doubles for every 10°C of temperature increase.
- +V_S and -V_S denote the positive and negative power supply rail respectively.
- Rating applies if the output current alternates between both output transistors at a rate faster than 60Hz.
- Derate max supply rating .625 V/°C below 25°C case. No derating needed above 25°C case.

CAUTION

The PA88 is constructed from MOSFET transistors. ESD handling procedures must be observed.

The internal substrate contains beryllia (BeO). Do not break the seal. If accidentally broken, do not crush, machine, or subject to temperatures in excess of 850°C to avoid generating toxic fumes.

TYPICAL PERFORMANCE
GRAPHS

PA88 • PA88A

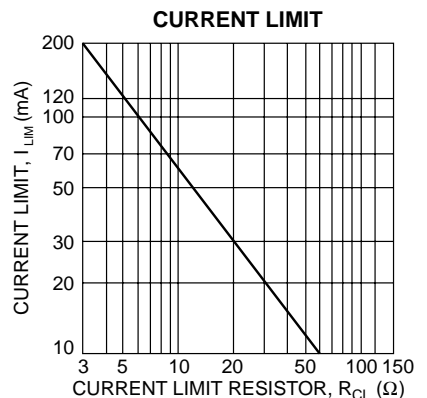
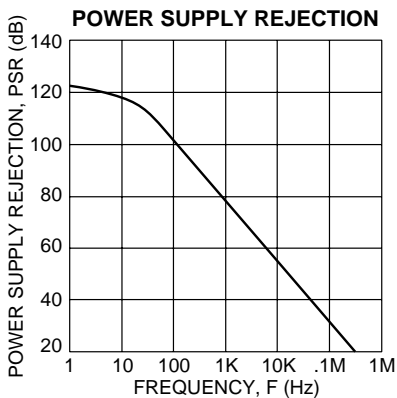
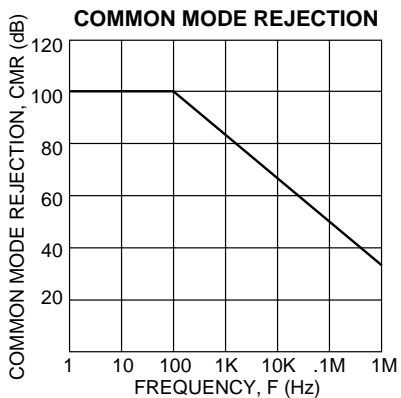
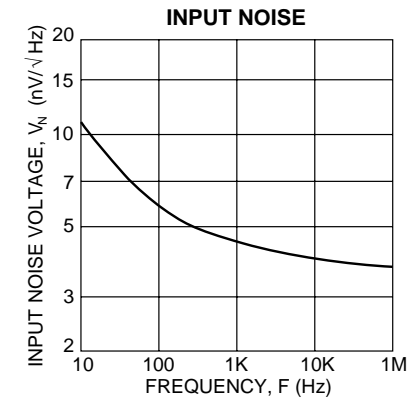
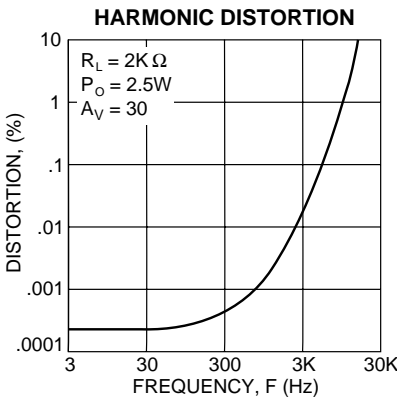
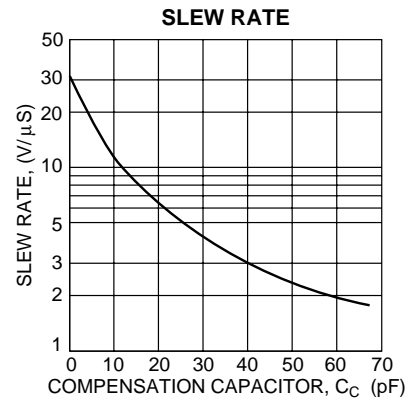
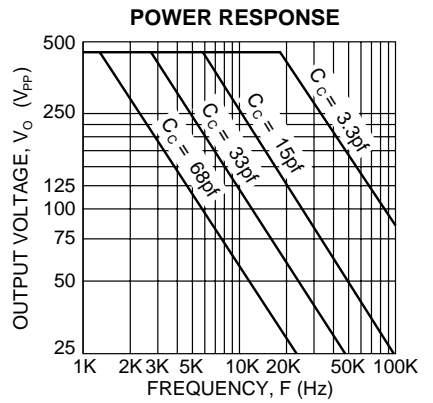
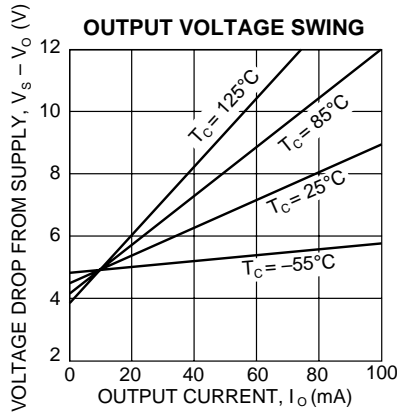
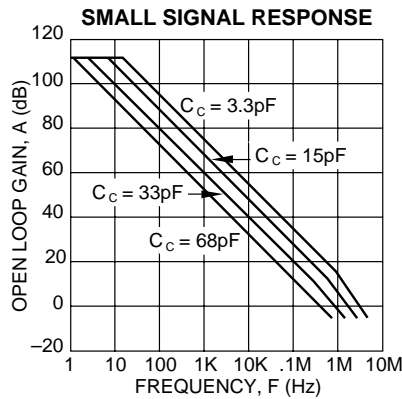
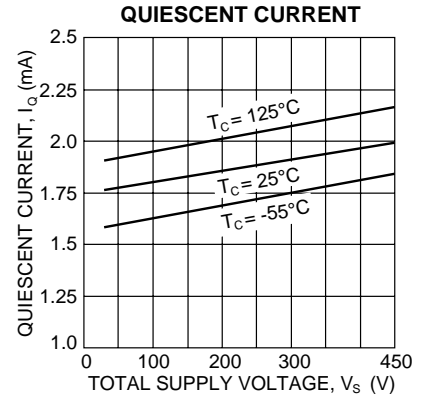
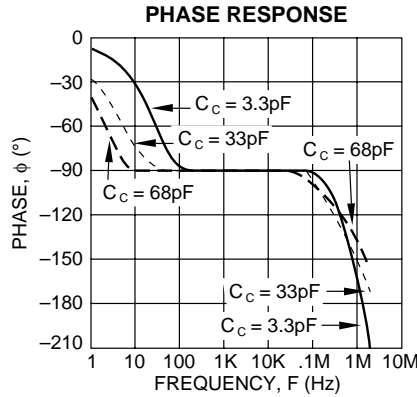
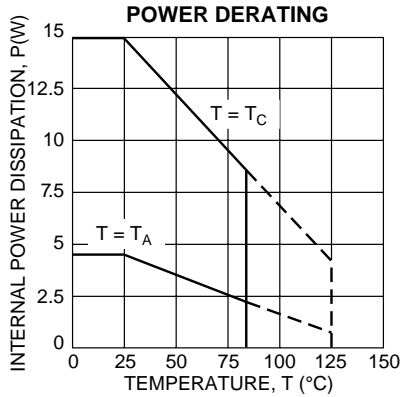

GENERAL

Please read the "General Operating Considerations" section, which covers stability, supplies, heatsinking, mounting, current limit, SOA interpretation, and specification interpretation. Additional information can be found in the application notes. For information on the package outline, heatsinks, and mounting hardware, consult the "Accessory and Package Mechanical Data" section of the handbook.

CURRENT LIMIT

For proper operation, the current limit resistor (R_{CL}) must be connected as shown in the external connection diagram. The minimum value is 3.5 ohm, however for optimum reliability the resistor value should be set as high as possible. The value is calculated as follows; with the maximum practical value of 150 ohms.

$$R_{CL} = \frac{.7}{I_{LIM}}$$

SAFE OPERATING AREA (SOA)

The MOSFET output stage of this power operational amplifier has two distinct limitations:

1. The current handling capability of the MOSFET geometry and the wire bonds.
2. The junction temperature of the output MOSFETs.

NOTE: The output stage is protected against transient flyback.

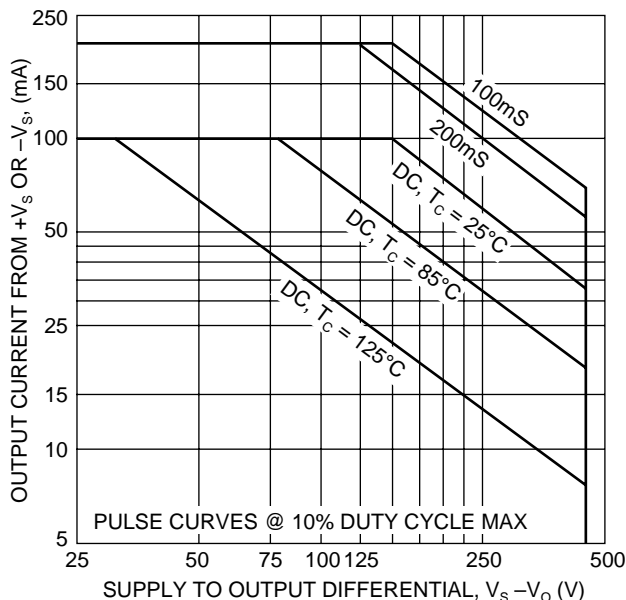

However, for protection against sustained, high energy flyback, external fast-recovery diodes should be used.

INPUT PROTECTION

Although the PA88 can withstand differential input voltages up to $\pm 25V$, additional external protection is recommended, and required at total supply voltages above 300 volts. In most

applications 1N4148 or 1N914 signal diodes are sufficient (D1, D2 in Figure 2a). In more demanding applications where low leakage or low capacitance are of concern 2N4416 or 2N5457-2N5459 JFETs connected as diodes will be required (Q1, Q2 in Figure 2b). In either case the input differential voltage will be clamped to $\pm .7V$. This is sufficient overdrive to produce maximum power bandwidth.

POWER SUPPLY PROTECTION

Unidirectional zener diode transient suppressors are recommended as protection on the supply pins. The zeners clamp transients to voltages within the power supply rating and also clamp power supply reversals to ground. Whether the zeners are used or not, the system power supply should be evaluated for transient performance including power-on overshoot and power-off polarity reversal as well as line regulation.

Conditions which can cause open circuits or polarity reversals on either power supply rail should be avoided or protected against. Reversals or opens on the negative supply rail is known to induce input stage failure. Unidirectional transzorbos prevent this, and it is desirable that they be both electrically and physically as close to the amplifier as possible.

STABILITY

The PA88 has sufficient phase margin to be stable with most capacitive loads at a gain of 4 or more, using the recommended phase compensation.

The PA88 is externally compensated and performance can be tailored to the application. Use the graphs of small signal response and power response as a guide. The compensation capacitor C_C must be rated at 500V working voltage. An NPO capacitor is recommended. The compensation network $C_C R_C$ must be mounted closely to the amplifier pins 7 and 8 to avoid spurious oscillation.

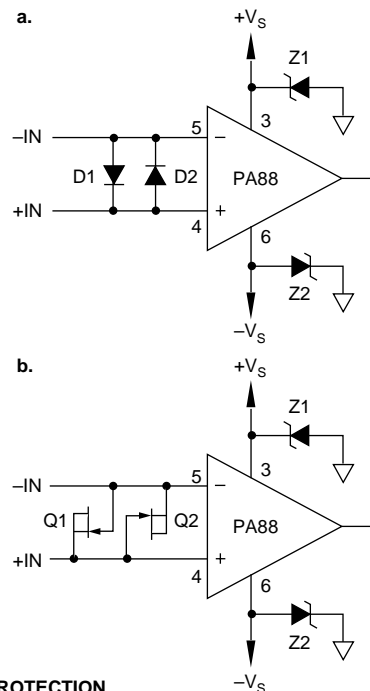

FIGURE 2. OVERVOLTAGE PROTECTION