

1.5 Amp Low Dropout Positive Voltage Regulators

The PJ1086 series of high performance positive voltage regulators designed for use in applications requiring low dropout performance at full rated current. Additionally, the PJ1086 Series provides excellent regulation over variations due to changes in line, load and temperature. Outstanding features include low dropout performance at rated current, fast transient response, internal current limiting and thermal shutdown protection of the output device. The PJ1086 Series are three terminal regulators with fixed and adjustable voltage options available in popular packages.

FEATURES

- Low dropout voltage 1.3V max.
- Full current rating over line and temperature
- Fast transient response
- $\pm 2\%$ Total output regulation over line, load and temperature
- Adjust pin current max $120 \mu A$ over temperature
- Line regulation typical 0.015%.
- Load regulation typical 0.05%.
- Fixed/adjustable output voltage
- TO-220 & TO-263 ,TO-252 package

BLOCK DIAGRAM

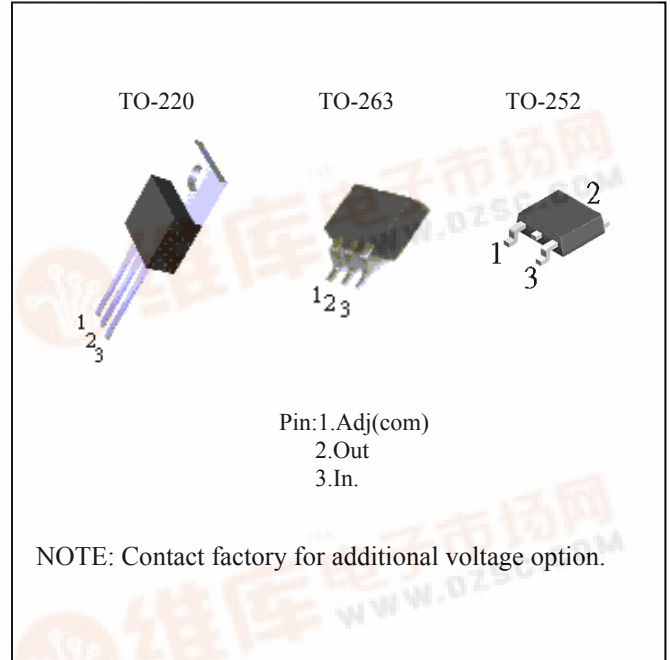
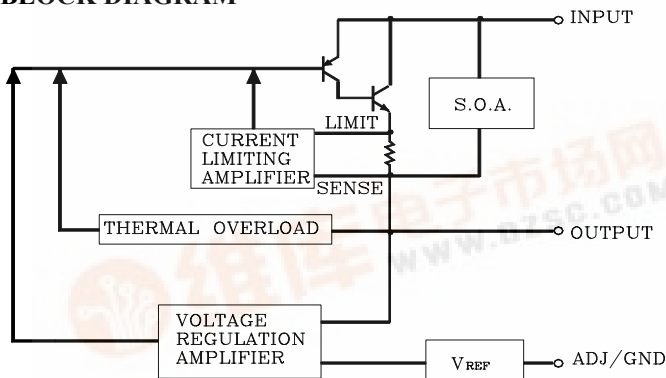

ORDERING INFORMATION

Device	Operating Temperature (Ambient)	Package
PJ1086CZ PJ1086CZ-2.5 PJ1086CZ-3.3	-20°C ~ +85°C	TO-220
PJ1086CM PJ1086CM-2.5 PJ1086CM-3.3		TO-263
PJ1086CP PJ1086CP-2.5 PJ1086CP-3.3		TO-252

ABSOLUTE MAXIMUM RATING

Parameter	Symbol	Maximum	Units
Input Voltage	V_{IN}	7	V
Power Dissipation	P_D	Internally Limited	W
Thermal Resistance Junction to Case	θ_{JC}	2.5	°C/W
Thermal Resistance Junction to Ambient	θ_{JA}	50	
Operating Junction Temperature Range	T_J	0 to +125	°C
Operating Ambient Temperature Range	T_A	-20 to +85	
Storage Temperature Range	T_{STG}	-25 to 150	
Lead Temperature (Soldering) 10 Sec.	T_{LEAD}	260	



1.5 Amp Low Dropout Positive Voltage Regulators

ELECTRICAL CHARACTERISTICS

Unless otherwise specified, Adjust $V_{IN}=2.75V$ to $12V$ and Adjust $I_O=10mA$ to $1.5A$

Fixed $V_{IN}=4.75V$ to $12V$ and Fixed $I_O=10mA$ to $1.5A$

Parameter	Symbol	Test Conditions			Test Limits			Units
		$V_{IN}-V_{OUT}$	I_O	$T_J^{(4)}$	Min	Typ	Max	
Output Voltage ⁽¹⁾	V_O	5V	10mA	25	0.99 V _o	V_O	1.01 V _o	V
Fixed Voltage				Over Temp.	0.98 V _o		1.02 V _o	
Reference Voltage ⁽¹⁾	V_{REF}	5V	10mA	25	1.238	1.250	1.262	V
Adj Voltage				Over Temp.	1.225		1.275	
Line Regulation ⁽¹⁾ ($V_{in}-V_{out}=3V$)	$REG_{(LINE)}$		10mA	25		0.015	0.2	%
				Over Temp.		0.035		
Load Regulation ⁽¹⁾ ($V_{in}-V_{out}=3V$)	$REG_{(LOAD)}$			25		0.05	0.3	%
				Over Temp.		0.2	0.4	
Dropout Voltage $\Delta V_{REF}=1\%$	V_D			25		1		V
						1.1	1.3	
Current Limit ($V_{in}-V_{out}=5V$)	I_{CL}				1.6	2.5		A
Quiescent Current Fixed Model	I_Q	5V				12	14	mA
Temperature Coefficient	T_c					0.005		%/°C
Adjust Pin Current	I_{ADJ}			25		55		μA
							120	
Adjust Pin Current Change	ΔI_{ADJ}					0.2	5	
Temperature Stability	T_s	5V	500mA	Over Temp.		0.5		%
Minimum Load Current Adjust Model	I_O	5V				5	10	mA
RMS Output Noise ⁽²⁾	V_N			25		0.003		%V _O
Ripple Rejection Ratio ⁽³⁾	R_A	5V	1.5A	Over Temp.	60	72		dB

(1)Low duty cycle pulse testing with Kelvin connections required.

(2)Bandwidth of 10Hz to 10KHz.

(3)120Hz input ripple (C_{ADJ} for ADJ)= $25 \mu F$.

(4)Over Temp.-over specified operating junction temperature range.

1.5 Amp Low Dropout Positive Voltage Regulators

Typical Application Circuit

FIXED VOLTAGE REGULATOR (1)(2)

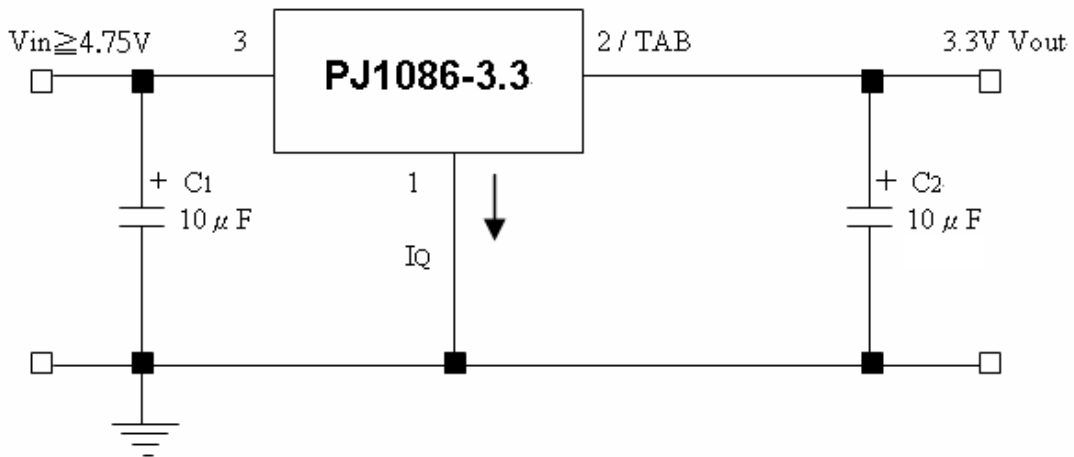

- (1) C₁ NEEDED IF DEVICE IS FAR FROM FILTER CAPACITORS
- (2) C₂ REQUIRED FOR STABILITY

ADJUSTABLE VOLTAGE REGULATOR (1)(2)

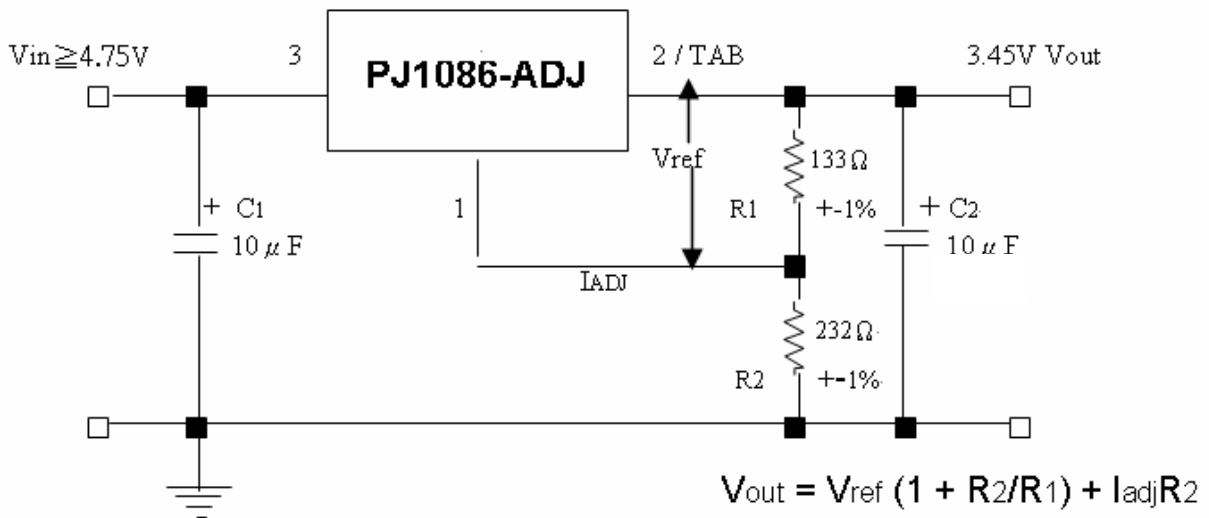

- (1) C₁ NEEDED IF DEVICE IS FAR FROM FILTER CAPACITORS
- (2) C₂ REQUIRED FOR STABILITY

1.5 Amp Low Dropout Positive Voltage Regulators

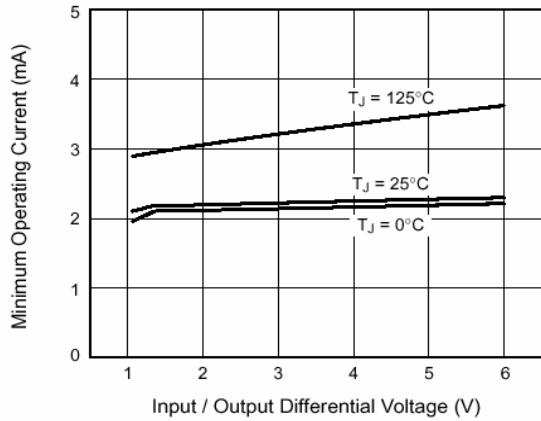

Fig. 1 – Minimum Load Current (Adjustable Version)

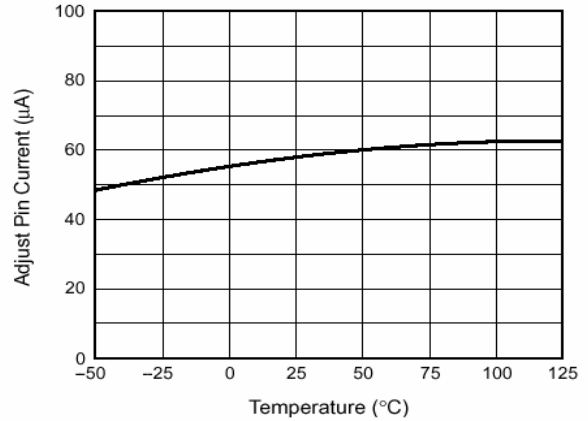

Fig. 2 – Adjust Pin Current

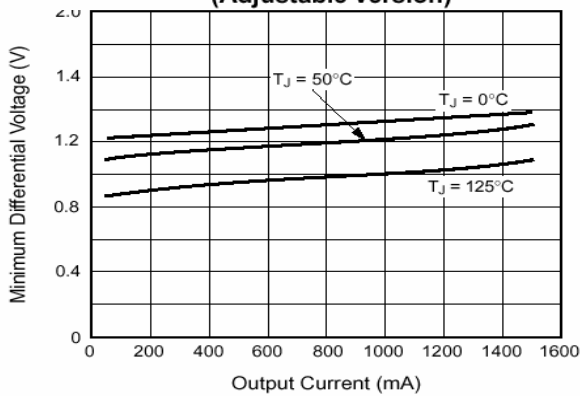

Fig. 3 – Dropout Voltage ($V_{OUT} = 3.3\text{V}$)

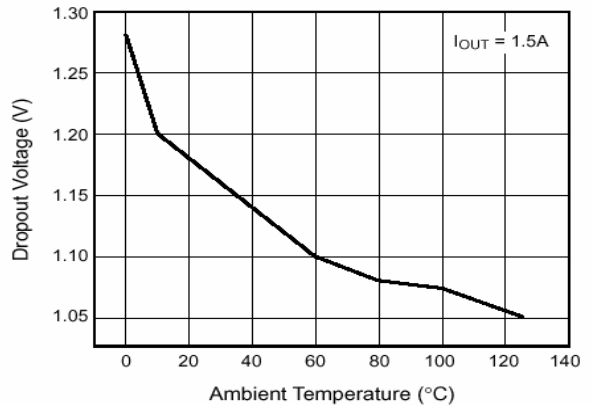

Fig. 4 – Dropout Voltage v.s. Temperature

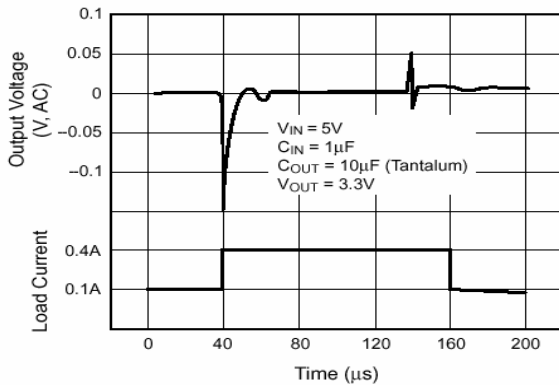

Fig. 5 – Load Transient Response

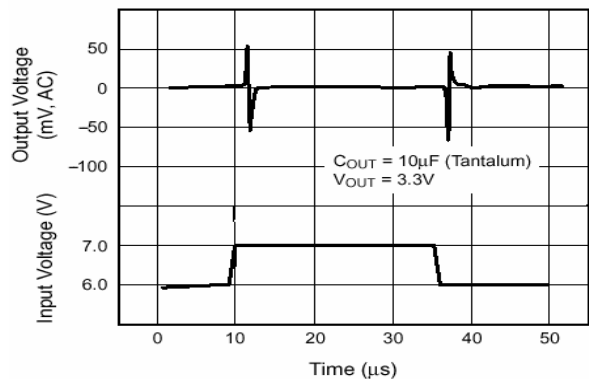

Fig. 6 – Line Transient Response

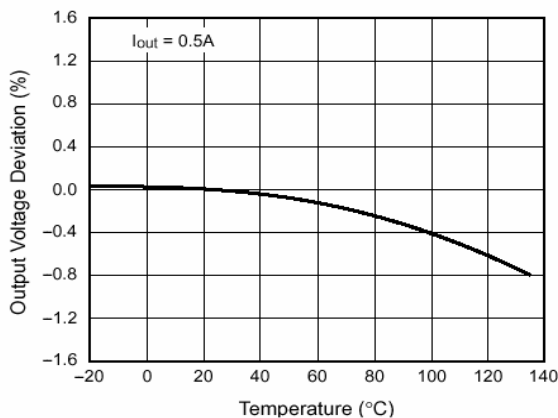

Fig. 7 – Temperature Stability

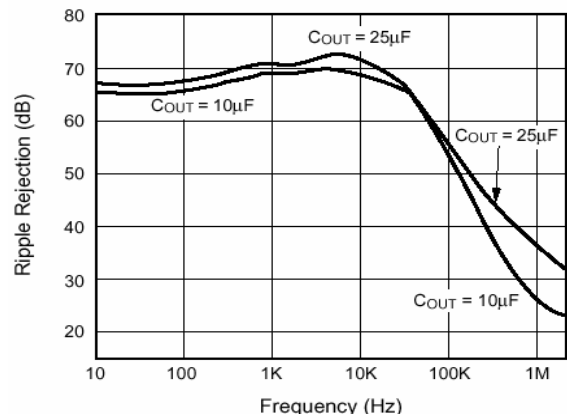
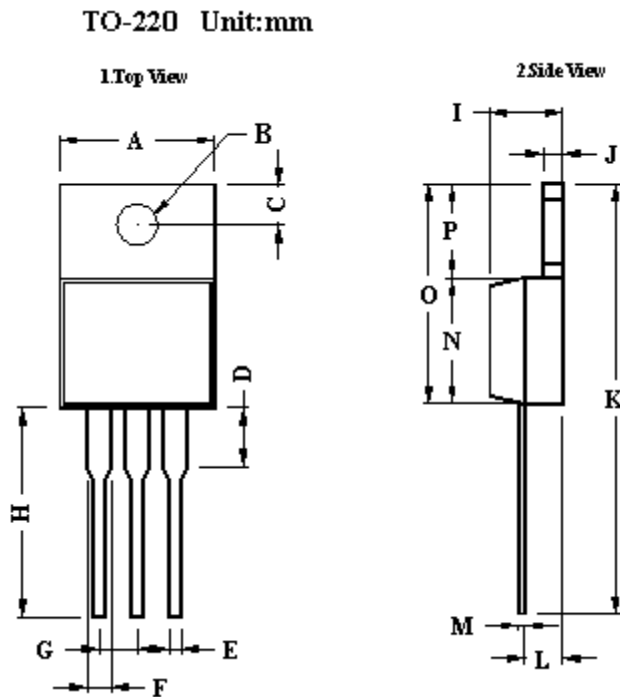

Fig. 8 – Ripple Rejection (with $C_{adj} = 25\mu\text{F}$)

1.5 Amp Low Dropout Positive Voltage Regulators

TO-220 Mechanical drawing



TO-220 DIMENSION				
DIM	MILLIMETERS		INCHES	
	MIN	MAX	MIN	MAX
A	10.00	10.50	0.394	0.413
B	3.24	4.44	0.128	0.175
C	2.44	2.94	0.096	0.116
D	3.565	4.315	0.140	0.170
E	0.68	0.92	0.027	0.036
F	1.115	1.485	0.044	0.058
G	2.345	2.715	0.092	0.107
H	13.49	14.31	0.531	0.563
I	4.475	5.225	0.176	0.206
J	1.15	1.39	0.045	0.055
K	27.78	29.62	1.094	1.166
L	2.175	2.925	0.086	0.115
M	0.297	0.477	0.012	0.019
N	8.28	8.80	0.326	0.346
O	14.29	15.31	0.563	0.603
P	6.01	6.51	0.237	0.256

TO-263 Mechanical drawing

TO-263 Unit:mm

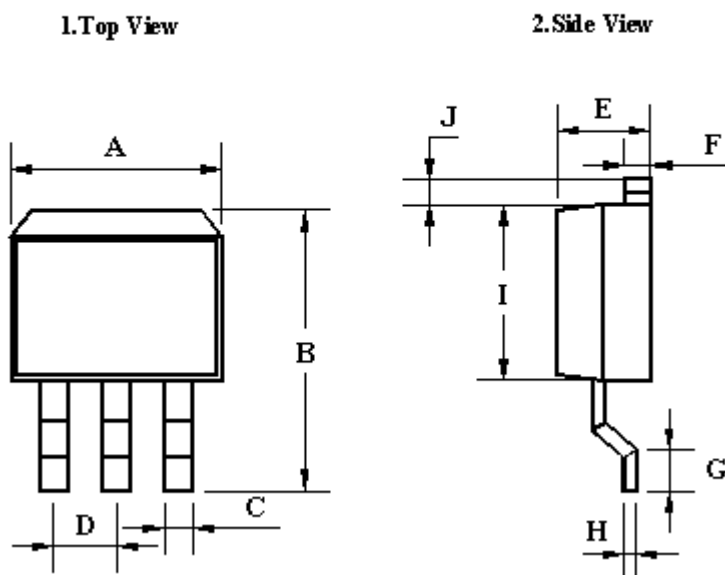

TO-263 DIMENSION				
DIM	MILLIMETER S		INCHES	
	MIN	MAX	MIN	MAX
A	10.00	10.50	0.394	0.413
B	14.60	15.87	0.575	0.625
C	0.68	0.92	0.027	0.036
D	2.42	2.66	0.095	0.105
E	4.31	4.83	0.170	0.190
F	1.14	1.40	0.045	0.055
G	2.28	2.79	0.090	0.110
H	0.45	0.73	0.018	0.029
I	8.28	8.80	0.326	0.346
J	1.14	1.4	0.045	0.055

1.5 Amp Low Dropout Positive Voltage Regulators

TO-252 Mechanical drawing

TO-252 Unit:mm

1.Top View

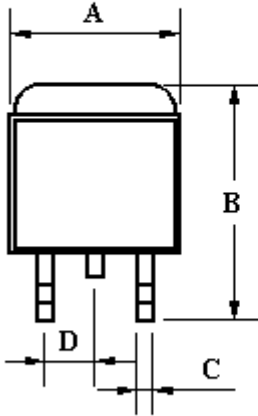

2.Side View

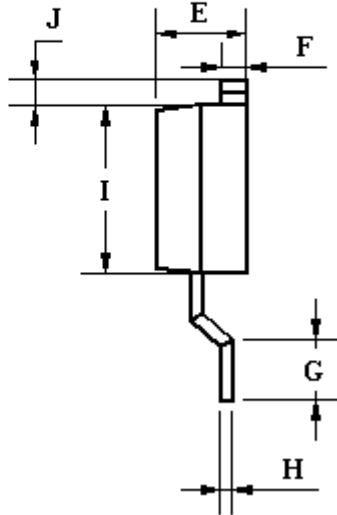

TO-252 DIMENSION				
DIM	MILLIMETERS		INCHES	
	MIN	MAX	MIN	MAX
A	6.57	6.84	0.259	0.269
B	9.25	10.40	0.364	0.409
C	0.62	0.76	0.024	0.030
D	2.56	2.67	0.101	0.105
E	2.30	2.39	0.090	0.094
F	0.49	0.57	0.019	0.022
G	1.46	1.58	0.057	0.062
H	0.52	0.57	0.020	0.022
I	5.34	5.55	0.210	0.219
J	1.46	1.64	0.057	0.065