

# PTF 10043

## 12 Watts, 1.9–2.0 GHz

### GOLDMOS® Field Effect Transistor

#### Description

The PTF 10043 is an internally matched GOLDMOS FET intended for large signal amplifier applications from 1.9 to 2.0 GHz. Rated at 12 watts, it operates at 45% efficiency with 12 dB gain. Nitride surface passivation and full gold metallization ensure excellent device lifetime and reliability.

- **INTERNALLY MATCHED**
- **Performance at 2.0 GHz, 26 Volts**
  - Output Power = 12 Watts Min
  - Power Gain = 12 dB Typ at 3 Watts
  - Efficiency = 45% Typ
- **Full Gold Metallization**
- **Silicon Nitride Passivated**
- **Back Side Common Source**
- **Excellent Thermal Stability**
- **100% Lot Traceability**

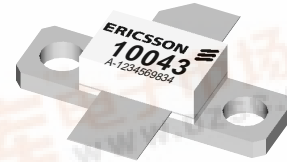
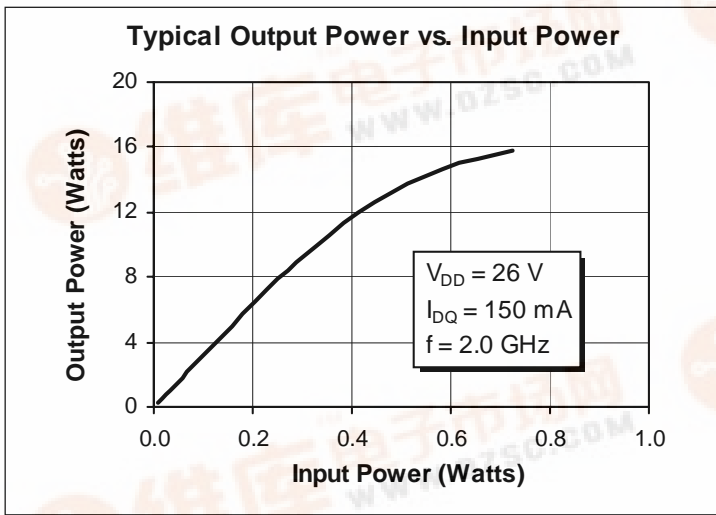

Package 20222

#### RF Specifications (100% Tested)

Characteristic	Symbol	Min	Typ	Max	Units
<b>Gain</b> ( $V_{DD} = 26\text{ V}$ , $P_{OUT} = 3\text{ W}$ , $I_{DQ} = 150\text{ mA}$ , $f = 1.93, 2.0\text{ GHz}$ )	$G_{ps}$	11	12	—	dB
<b>Power Output at 1 dB Compressed</b> ( $V_{DD} = 26\text{ V}$ , $P_{OUT} = 12\text{ W}$ , $I_{DQ} = 150\text{ mA}$ , $f = 2.0\text{ GHz}$ )	p-1dB	12	14	—	Watts
<b>Drain Efficiency</b> ( $V_{DD} = 26\text{ V}$ , $P_{OUT} = 12\text{ W}$ , $I_{DQ} = 150\text{ mA}$ , $f = 2.0\text{ GHz}$ )	$\eta_D$	40	45	—	%
<b>Load Mismatch Tolerance</b> ( $V_{DD} = 26\text{ V}$ , $P_{OUT} = 12\text{ W}$ , $I_{DQ} = 150\text{ mA}$ , $f = 2.0\text{ GHz}$ —all phase angles at frequency of test)	$\Psi$	—	—	10:1	—

All published data at  $T_{CASE} = 25^\circ\text{C}$  unless otherwise indicated.

## Electrical Characteristics (100% Tested)

Characteristic	Conditions	Symbol	Min	Typ	Max	Units
Drain-Source Breakdown Voltage	$V_{GS} = 0\text{ V}, I_D = 5\text{ mA}$	$V_{(BR)DSS}$	65	—	—	Volts
Zero Gate Voltage Drain Current	$V_{DS} = 26\text{ V}, V_{GS} = 0\text{ V}$	$I_{DSS}$	—	—	1.0	mA
Gate Threshold Voltage	$V_{DS} = 10\text{ V}, I_D = 75\text{ mA}$	$V_{GS(th)}$	3.0	—	5.0	Volts
Forward Transconductance	$V_{DS} = 10\text{ V}, I_D = 2\text{ A}$	$g_{fs}$	—	0.8	—	Siemens

## Maximum Ratings

Parameter	Symbol	Value	Unit
Drain-Source Voltage	$V_{DSS}$	65	Vdc
Gate-Source Voltage	$V_{GS}$	$\pm 20$	Vdc
Operating Junction Temperature	$T_J$	200	$^{\circ}\text{C}$
Total Device Dissipation Above $25^{\circ}\text{C}$ derate by	$P_D$	55 0.31	Watts $\text{W}/^{\circ}\text{C}$
Storage Temperature Range	$T_{STG}$	$-40$ to $+150$	$^{\circ}\text{C}$
Thermal Resistance ( $T_{CASE} = 70^{\circ}\text{C}$ )	$R_{\theta JC}$	3.2	$^{\circ}\text{C}/\text{W}$

## Typical Performance

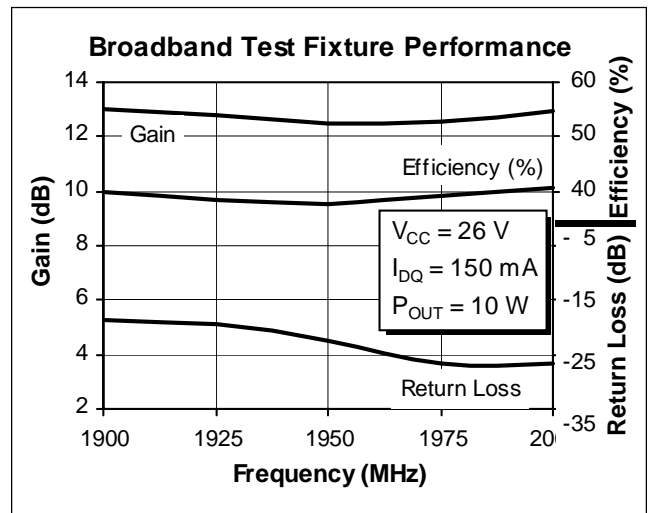
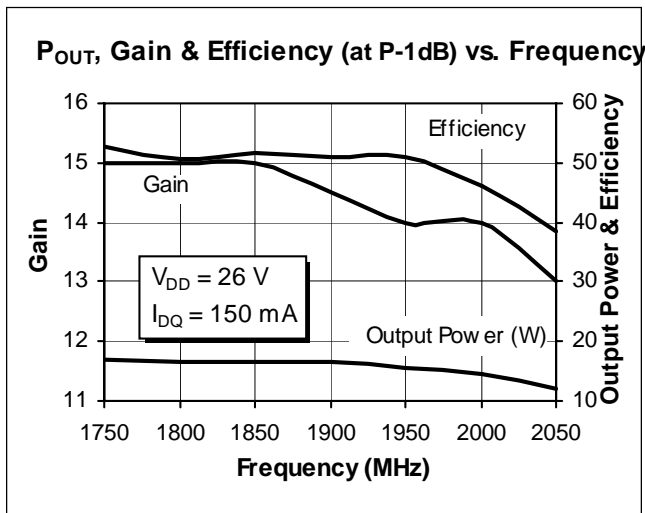

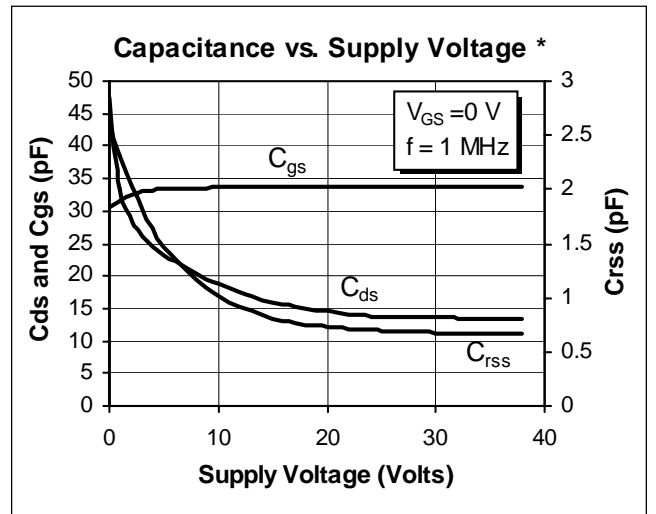
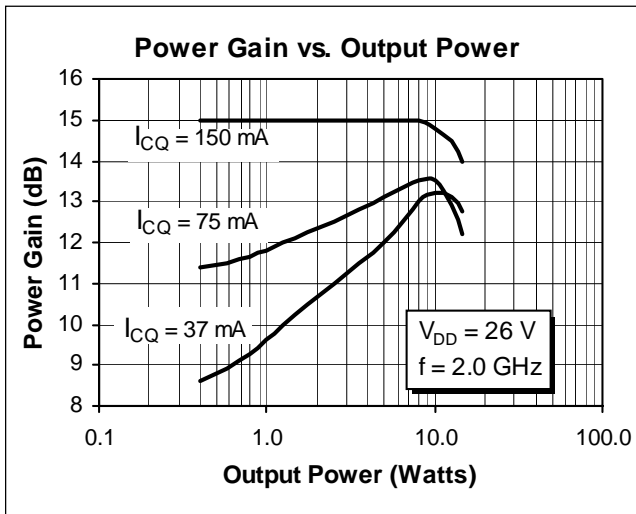
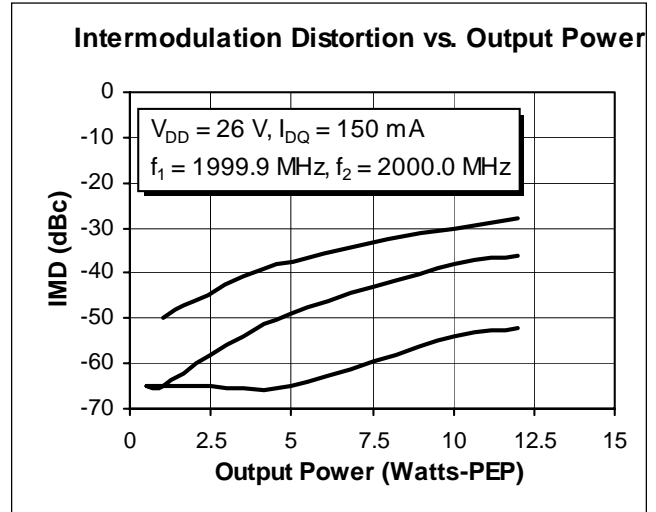
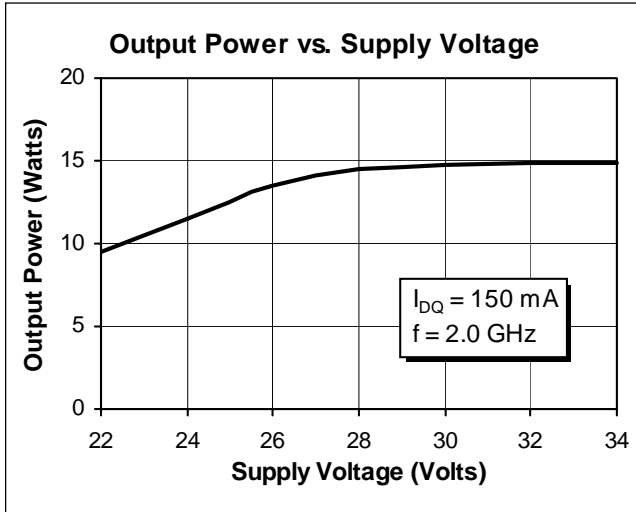

\*This part is internally matched. Measurements of the finished product will not yield these figures.

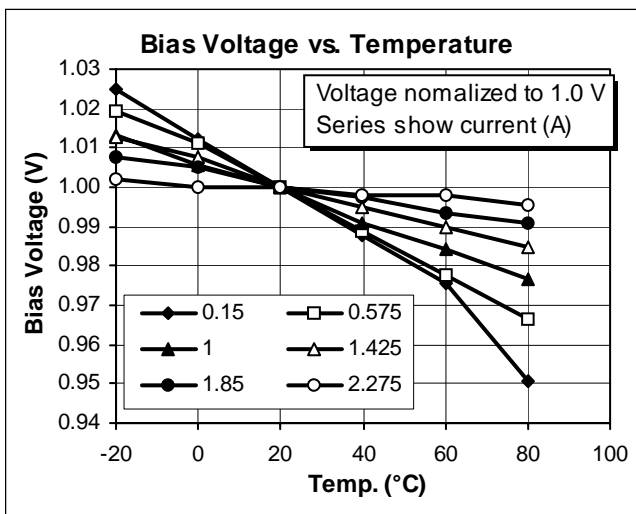

# PTF 10043



## Impedance Data

$V_{DS} = 26 \text{ V}$ ,  $P_{OUT} = 12 \text{ W}$ ,  $I_{DQ} = 150 \text{ mA}$

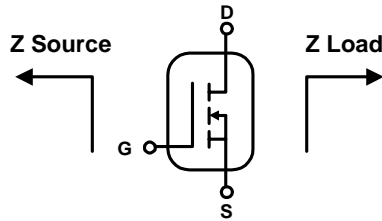

Frequency GHz	Z Source $\Omega$		Z Load $\Omega$	
	R	$jX$	R	$jX$
1.75	2.8	-2.4	3.2	1.9
1.80	3.2	-2.7	3.0	1.5
1.85	3.0	-3.2	2.7	0.9
1.90	2.5	-3.1	2.4	0.4
1.95	2.3	-2.8	2.2	0.0
2.00	2.2	-2.5	1.9	-0.6
2.05	2.3	-2.3	1.7	-1.1

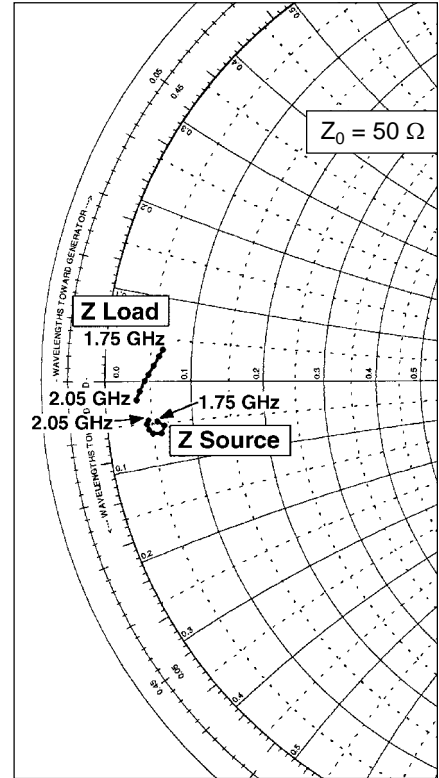

## Typical Scattering Parameters

$(V_{DS} = 28 \text{ V}$ ,  $I_D = 500 \text{ mA})$

f (MHz)	S11		S21		S12		S22	
	Mag	Ang	Mag	Ang	Mag	Ang	Mag	Ang
100	0.912	-143	14.7	86	0.007	0	0.641	-70
200	0.917	-150	11.5	80	0.006	-5	0.650	-82
300	0.951	-163	5.83	53	0.004	-16	0.750	-107
400	0.964	-168	3.71	39	0.002	0	0.824	-122
500	0.971	-171	2.63	28	0.002	65	0.881	-132
600	0.974	-174	1.99	20	0.003	94	0.931	-139
700	0.975	-175	1.56	12	0.006	98	0.952	-146
800	0.975	-177	1.26	6	0.008	95	0.950	-151
900	0.980	-178	1.07	0	0.010	93	0.951	-155
1000	0.979	-179	0.932	-5	0.012	92	0.948	-158
1100	0.981	180	0.846	-11	0.014	89	0.959	-160
1200	0.977	179	0.790	-16	0.015	86	0.965	-162
1300	0.975	177	0.763	-23	0.017	83	0.970	-164
1400	0.965	176	0.759	-30	0.019	82	0.972	-166
1500	0.951	175	0.782	-39	0.021	80	0.974	-168
1600	0.929	174	0.828	-51	0.023	78	0.975	-169
1700	0.904	174	0.880	-68	0.025	74	0.986	-170
1800	0.885	175	0.884	-89	0.027	70	1.00	-171
1900	0.892	177	0.802	-113	0.029	67	1.02	-173
2000	0.918	177	0.650	-134	0.030	61	1.02	-175
2100	0.942	177	0.489	-151	0.028	54	1.01	-177
2200	0.964	176	0.366	-162	0.025	56	1.01	-178

**Test Circuit**

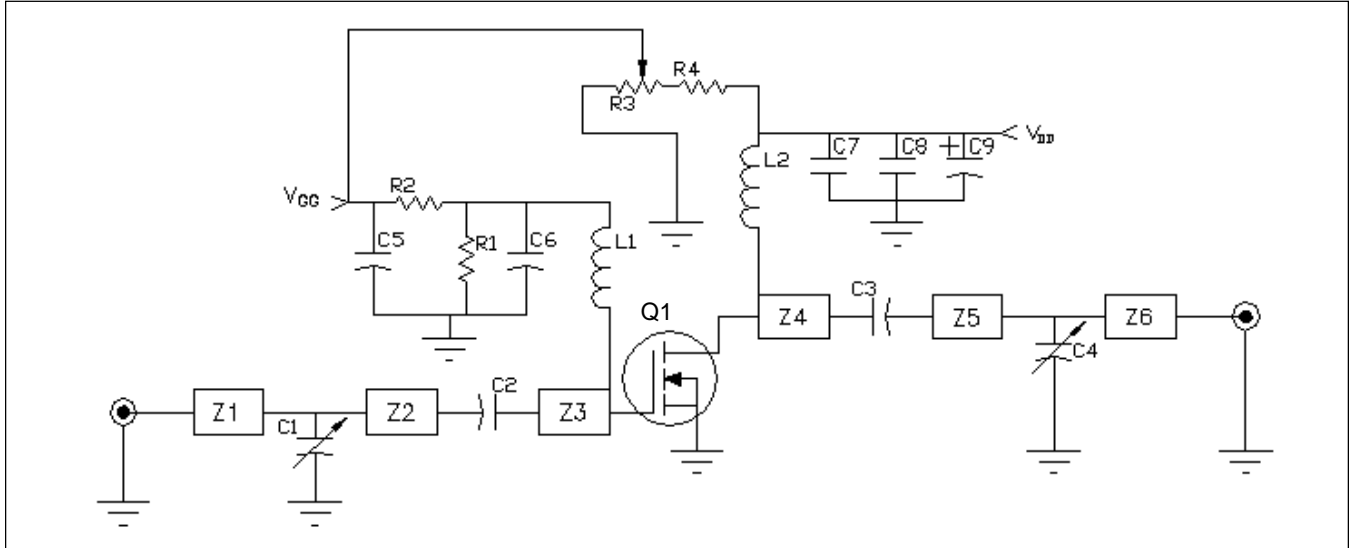

Block Diagram for  $f = 2.0$  GHz

Q1	PTF 10043	RF LDMOS FET
Z1, Z6	50 $\Omega$	Microstrip
Z2, Z5	50 $\Omega$ , 0.085 $\lambda$	Microstrip
Z3	7.5 $\Omega$ , 0.154 $\lambda$	Microstrip
Z4	7.9 $\Omega$ , 0.238 $\lambda$	Microstrip
C1, C4	0.3–3.5	Trim Capacitor
C2, C3, C6, C8	33 pF	Capacitor ATCB
C5, C7	0.1 $\mu$ F, 50 V	Capacitor Digi-Key P4917-ND
C9	100 $\mu$ F, 50V	Electrolytic Capacitor Digi-Key P5276
L1, L2	#20 AWG	3 Turn, 0.12" I.D.
R1, R2	500 $\Omega$	Resistor
Circuit Board	.031" thick, $\epsilon_r = 4.0$ , G200, AlliedSignal, 2 oz. copper	

*Bias Parts (not shown on layout)*  
 R3 2 K Potentiometer  
 R4 10  $\Omega$  Resistor

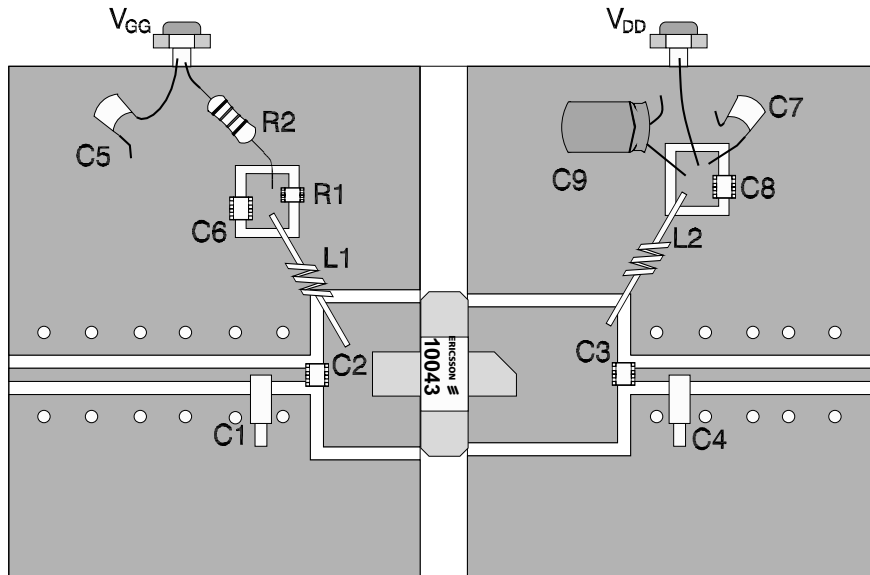

Parts Layout (not to scale)

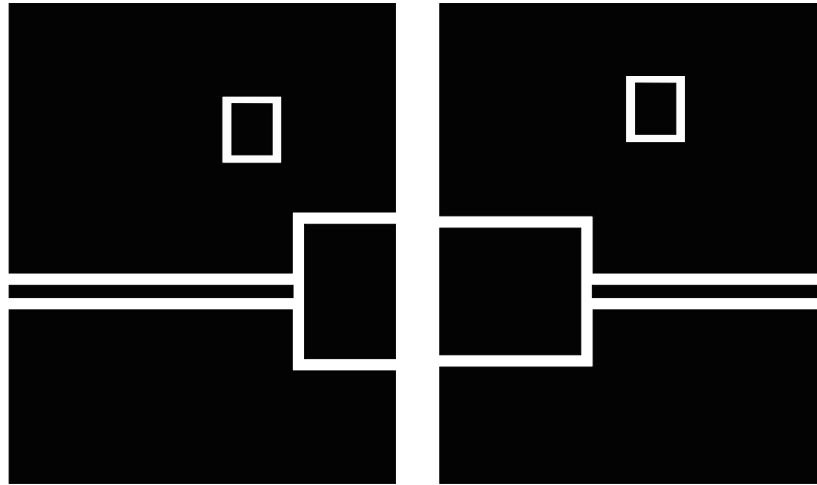

Artwork (not to scale)

**Package Mechanical Specifications**

