

# QF1D512

Simple and versatile FIR engine (SavFIRe™)



## APPLICATIONS

- Industrial Control
- Machine Monitoring
- Smart Sensors
- Medical Monitoring and Diagnostics
- Industrial Wireless Sensor Networks
- Homeland Security

## DESCRIPTION

A single channel, programmable digital filter designed for near seamless insertion in the serial data path of a digital signal or used as an FIR coprocessor. The device can be programmed using the Quickfilter Pro™ Design Software which supports most FIR digital filter configurations. The FIR filter has 512 taps capable of generating “brick wall” filters such as a low pass filter with a 1 kHz cutoff frequency and a total transition band of only 25 Hz. The filter can operate over a broad range of ADC data rates - from 10sps up to 500ksps and can support ADC's with resolutions ranging from 12 to 24 bits.

## ORDERING INFORMATION

Device	Package
QF1D512-QN-T	16-Pin QFN - Tape & Reel (Reel qty 1000)
QF1D512-DK	Development Kit

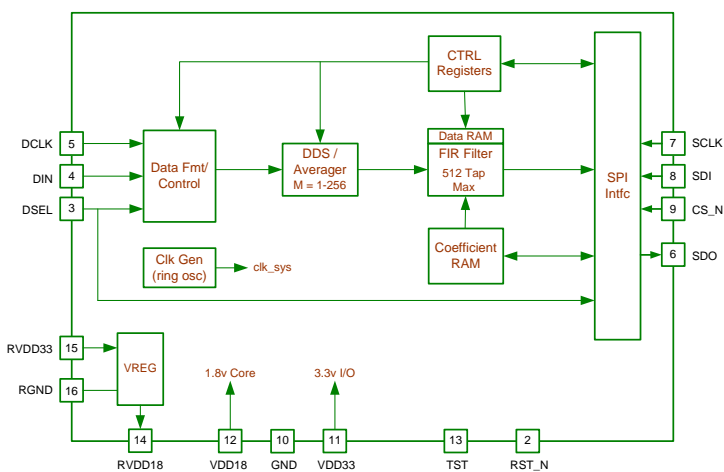

## FEATURES

- Maximum 512-tap symmetric or 256-tap non-symmetric digital FIR filter with 12 – 24 bit data words and up to 32 bit coefficients
- Programmable Averaging and Down-sampler pre-FIR, including bypass mode
- Re-programmable in circuit
- Data Rate: Up to 500ksps
- Data Interface: Supports SPI and synchronous serial modes up to 20 MHz, operates with a wide variety of ADC's.
- SPI Configuration Interface support all 4 modes
- Multiple devices can be daisy chained, with programmable bypass mode.
- 3.3V Digital I/O, 5 Volt Tolerant with 3.3V & 1.8V Supplies, Internal regulator for single rail operation
- Low Power: < 1mW @ 1 Ksps, 10mW @ 200Ksps
- Industrial Temp -40C to +85C
- Package: 16-pin QFN (3 X 3 mm)

## QUICKFILTER DEVELOPMENT KIT

### (QF1D512-DK)

- Windows® Based Software for Rapid Filter Design and IC Configuration
- In-System Programmability (ISP) Through SPI Port
- Evaluation board for verification of device performance

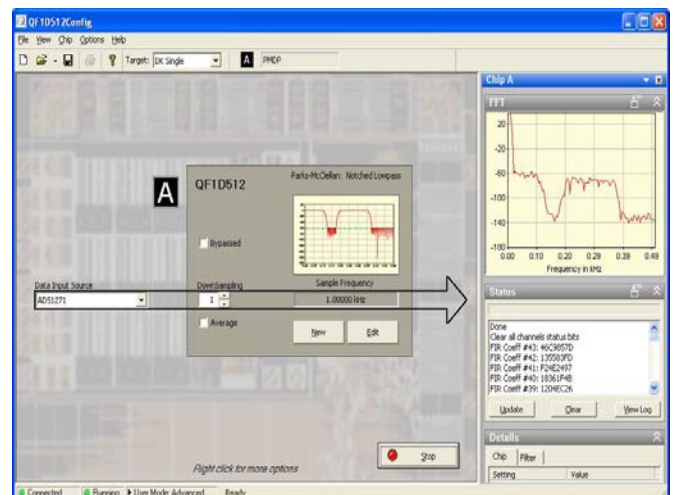

TABLE OF CONTENTS

- 1 SPECIFICATIONS ..... 4**
  - 1.1 ABSOLUTE MAXIMUM RATINGS ..... 4
  - 1.2 PACKAGE ASSEMBLY ..... 4
  - 1.3 RECOMMENDED OPERATING CONDITIONS ..... 4
  - 1.4 ELECTRICAL CHARACTERISTICS ..... 5
  - 1.5 TIMING REQUIREMENTS ..... 5
  - 1.6 TYPICAL PERFORMANCE CHARACTERISTICS ..... 5
  
- 2 PINOUT AND PIN DESCRIPTIONS ..... 6**
  
- 3 GENERAL DESCRIPTION ..... 7**
  - 3.1 DATA FORMAT AND CONTROL ..... 7
  - 3.2 AVERAGING AND DOWN-SAMPLER ..... 7
  - 3.3 FINITE IMPULSE RESPONSE FILTER (FIR) ..... 7
  - 3.4 SERIAL INTERFACE - SERIAL PERIPHERAL INTERFACE (SPI) ..... 7
  - 3.5 VOLTAGE REGULATOR ..... 7
  
- 4 SOFTWARE ..... 8**
  - 4.1 DEVICE CONFIGURATION ..... 8
  - 4.2 QUICKFILTER DEVELOPMENT KIT (QF1D512-DK) ..... 8
  
- 5 CONFIGURATION INTERFACE ..... 8**
  - 5.1 MODES OF OPERATION ..... 8
  - 5.2 SENDING COMMANDS IN FILTER MODE ..... 8
  
- 6 DATA INTERFACE ..... 9**
  - 6.1 MODES OF OPERATION ..... 9
  
- 7 AVERAGING AND DOWNCONVERTER ..... 10**
  - 7.1 MODES OF OPERATION ..... 10
  
- 8 FIR FILTER ..... 11**
  - 8.1 MODES OF OPERATION ..... 11
  - 8.2 FIR LATENCY ..... 11

---

<b>9</b>	<b><u>VOLTAGE REGULATOR</u></b>	<b>11</b>
9.1	MODE OF OPERATION	11
<b>10</b>	<b><u>CONTROL REGISTERS</u></b>	<b>12</b>
10.1	OVERVIEW	12
10.2	CONFIGURATION REGISTERS	13
10.3	COEFFICIENT MEMORY	21
<b>11</b>	<b><u>OPERATING MODE CONFIGURATIONS</u></b>	<b>22</b>
11.1	SPI FIR COPROCESSOR MODE	22
11.2	INLINE NORMAL SPI MODE	22
11.3	INLINE CONTINUOUS SPI MODE	23
11.4	INLINE SYNCHRONOUS SERIAL MODE	23
<b>12</b>	<b><u>PACKAGING INFORMATION</u></b>	<b>24</b>
<b>13</b>	<b><u>LIST OF FIGURES</u></b>	<b>26</b>
<b>14</b>	<b><u>LIST OF TABLES</u></b>	<b>26</b>

## 1 SPECIFICATIONS

### 1.1 Absolute Maximum Ratings

Stresses above those listed under Absolute Maximum Ratings can cause permanent device failure. Functionality at or above these limits is not implied. Exposure to absolute maximum ratings for extended periods may affect device reliability.

Parameter	Min	Max	Units
Storage Temperature	-60	125	°C
Supply Voltage, $V_{DD18}$ to GND	-0.2V	2.2V	V
Supply Voltage, $V_{DD33}$ with respect to GND	-0.2V	4.0V	V
VREG Voltage, $V_{VREG33}$ with respect to GND	-0.2V	4.0V	V
Digital Input Voltage with respect to GND	-0.3	7	V
ESD Immunity (Human Body Model, JESD222 Class 1C))	TBD		V



**This integrated circuit can be damaged by ESD. Quickfilter Technologies recommends that all integrated circuits be handled with appropriate precautions. Failure to observe proper handling and installation procedures can cause damage.**

### 1.2 Package Assembly

The QF1D512 is offered in a “green” package (RoHS & no Sb/Br), assembled with enhanced environmentally compatible Pb-free and halide-free materials. The leads possess a matte-tin plating which is compatible with conventional board assembly processes or newer lead-free board assembly processes. The peak soldering temperature should not exceed 260°C during printed circuit board assembly.

### 1.3 Recommended Operating Conditions

Parameter	Symbol	Min	Typ	Max	Units
Supply Voltage 1.8	$V_{DD18}$	1.6	1.8	2.0	V
Supply Voltage 3.3	$V_{DD33}$	3.0	3.3	3.6	V
VREG Voltage 3.3	$V_{VREG33}$	3.0	3.3	3.6	V
Digital Input Voltage		0		5	V
Ambient Temperature	$T_A$	-40	25	85	°C

Note: Quickfilter guarantees the performance of this device over specified ranges by conducting electrical characterization over each range and by conducting a production test with single insertion coupled to periodic sampling.

## 1.4 Electrical Characteristics

Symbol	Parameter (Condition)	Min	Typ	Max	Units	Note
<b>Supply Current &amp; Power Dissipation</b>						
I <sub>DD18</sub>	1.8V Supply Operating Current		- f <sub>S</sub> = 1 kHz, 512 taps	0.04		mA
			- f <sub>S</sub> = 128 kHz, 512 taps	4.5		mA
			- f <sub>S</sub> = 256 kHz, 512 taps	8.5		mA
			- Standby	50		nA
I <sub>DD33</sub>	3.3V Supply Operating Current		- f <sub>S</sub> = 1kHz	TBD		uA
			- f <sub>S</sub> = 100kHz	TBD		uA
			- f <sub>S</sub> = 200kHz	TBD		uA
			- Standby	TBD		uA
P <sub>DD</sub>	Power Dissipation, Active		- f <sub>S</sub> = 1kHz	TBD		mW
			- f <sub>S</sub> = 100kHz	TBD		
			- f <sub>S</sub> = 200kHz	TBD		
			- Standby	TBD		
V <sub>OVREG</sub>	Voltage Regulator Output Voltage	1.566	1.8V	2.034	V	
I <sub>OVREG</sub>	Voltage Regulator Output Current	TBD	TBD	TBD	mA	
C <sub>OVREG</sub>	Voltage Regulator External Output Capacitor	0.1	1		uF	
C <sub>OVREG</sub> ESR	External Capacitor ESR		0.5	1	Ohm	
<b>Digital Inputs (DIN, DSEL, DCLK, SCLK, SDI, CSN, RST_N)</b>						
V <sub>IH</sub>	High-level Input Voltage, V <sub>DD33</sub> = 3.6V	2		3.9	V	
V <sub>IL</sub>	Low-level Input Voltage, V <sub>DD33</sub> = 3.0V	-0.3		0.8	V	
I <sub>IN</sub>	Input (leakage) current		+/- 1		uA	
C <sub>IN</sub>	Input Capacitance		tbd		pF	
R <sub>PU</sub>	Pull Up Resistance	40	75	190	Ohm	
R <sub>PD</sub>	Pull Down Resistance	40	75	190	Ohm	
<b>Digital Output (SDO)</b>						
V <sub>OH</sub>	High-level Output Voltage, DV <sub>DD33</sub> = 3.0V, I <sub>OH</sub> = -100uA	2.4			V	
V <sub>OL</sub>	Low-level Output Voltage, DV <sub>DD33</sub> = 3.0V, I <sub>OL</sub> = 100uA			0.4	V	
C <sub>O</sub>	Output Capacitance		tbd		pF	

## 1.5 Timing Requirements

Parameter	Min	Max	Units	Note
Sample Frequency* (f <sub>S</sub> )		500	KHz	
Data Input Clock Frequency (DCLK)		20	MHz	
Serial Port Clock Frequency (SCLK) in all modes		20	MHz	
Setup time Chip select (CSN) low to SCLK rising edge	tbd			
Setup time SDI before SCLK edge	tbd			
Hold time SDI after SCLK edge	tbd			
Setup time DSEL low to DCLK rising edge	tbd			
Setup time DIN before DCLK edge	tbd			
Hold time DIN after DCLK edge	tbd			

## 1.6 Typical Performance Characteristics

Default Conditions: T<sub>A</sub> = 25 C, V<sub>DD18</sub> = 1.8V, V<sub>DD33</sub> = 3.3V,

## 2 PINOUT and PIN DESCRIPTIONS

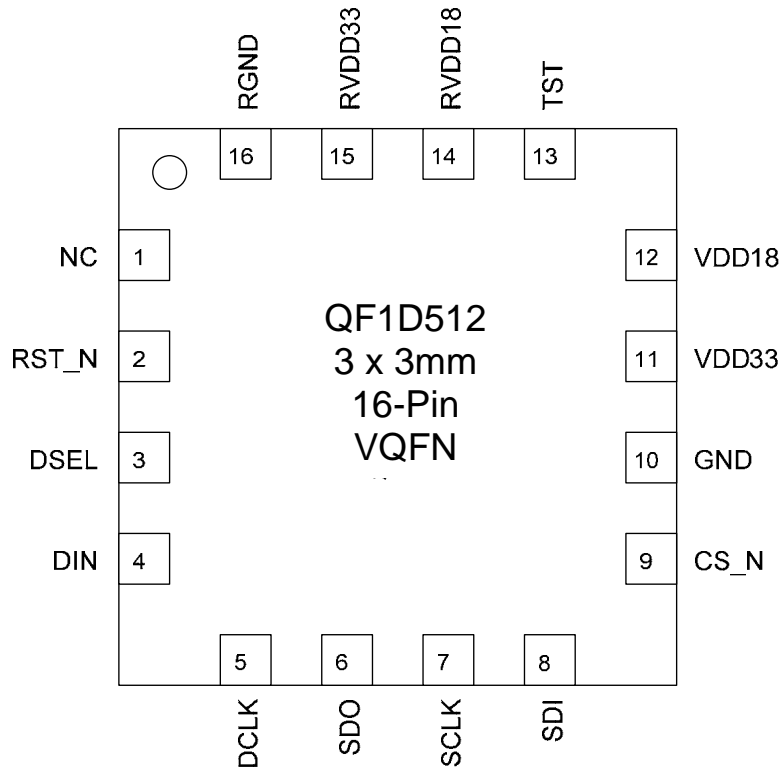

Figure 1: 16 Pin QFN Package Pin out

Table 1: Pin Descriptions

Pin	Signal Name	I/O	Type	Description
1	NC			No Connection
2	RST_N	I	Digital	Chip reset; active low; default internal pull-up
3	DSEL	I	Digital	SPI Mode: frames the data as a chip select; Synchronous Serial Mode: a frame pulse whose rising or falling edge identifies the 1 <sup>st</sup> bit of data; active high or low
4	DIN	I	Digital	Serial data input
5	DCLK	I	Digital	Data input clock used to capture DIN; active capture edge either high or low
6	SDO	O	Digital	Serial data output. Can be either cfg data or ADC/filter data depending on mode
7	SCLK	I	Digital	Serial input clock used for cfg data transfers; active capture edge either high or low
8	SDI	I	Digital	Serial_data input used for cfg data
9	CS_N	I	Digital	Cfg interface chip select; active low; default internal pull-up
10	GND	N/A	Return	Digital power supply return pin
11	VDD33	N/A	Power	Digital I/O voltage; 3.3 +- 10%
12	VDD18	N/A	Power	Digital Core voltage; 1.8 +- 10%
13	TST	I	Digital	Production scan test mode enable; active high; default internal pull-down
14	RVDD18	N/A	Power	Internal voltage regulator 1.8v output; tie to VDD18 when in use; tie to GND to disable
15	RVDD33	N/A	Power	Internal voltage regulator 3.3v input; tie to GND to disable
16	RGND	N/A	Return	Internal voltage regulator return pin

### 3 GENERAL DESCRIPTION

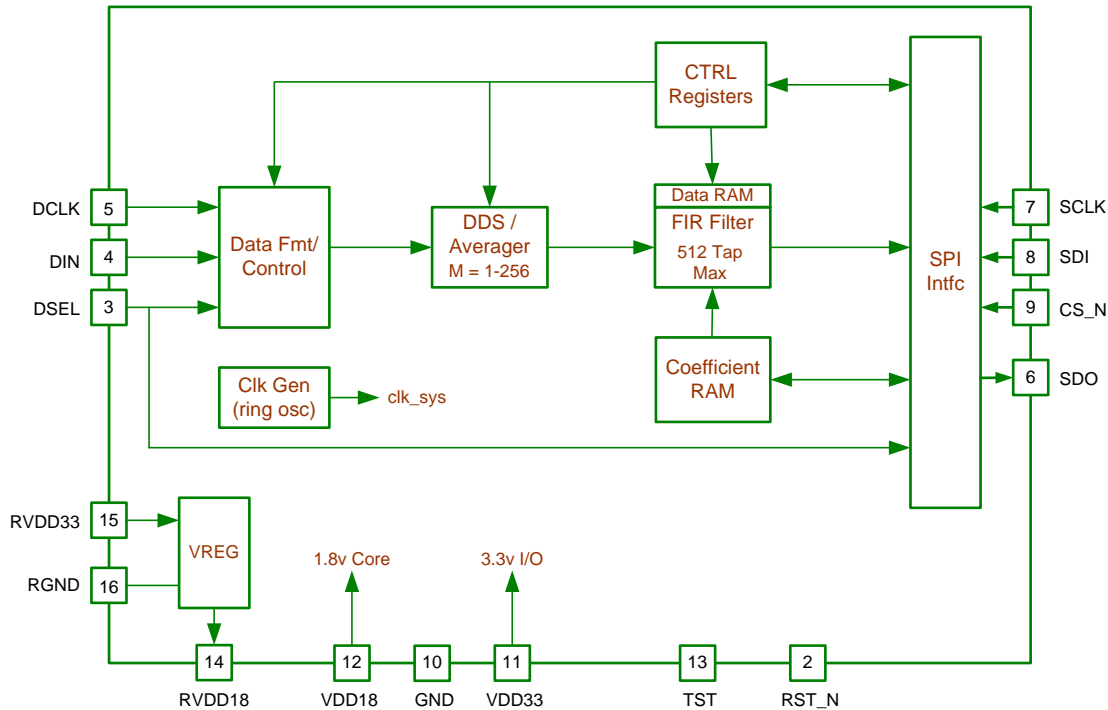

Figure 2: Functional Block Diagram

#### 3.1 Data Format and Control

The Data Format and Control block accepts the ADC serial data. It separates any header information and checks for data valid and then separates the data bits for processing. It also converts the data into the required format for the FIR filter.

#### 3.2 Averaging and Down-sampler

The Averaging / Down-sampler block down-samples the incoming data by a factor of 1 to 256. It also can be configured to average the down sampled data.

#### 3.3 Finite Impulse Response filter (FIR)

The FIR filter consists of up to 512 taps for a symmetric filter or 256 taps for an asymmetric filter.

#### 3.4 Serial Interface - Serial Peripheral Interface (SPI)

The configuration and data serial interfaces are fully compatible with a standard SPI bus. Both the DCLK and SCLK are capable of running at up to 20 MHz, although they may be run at much lower speeds. The QF1D512 operates in a SLAVE mode.

The configuration interface consists of the SCLK, CS\_N, SDI and SDO pins and is used to configure the control registers and program the coefficient memory space.

The data interface consists of the DCLK, DSEL, DIN, and SDO pins and allows for ADC data received on DIN to be filtered or passed through to SDO and on to the controlling device (uP, DSP, FPGA). DIN may also come from the controlling device (FIR coprocessor mode). If a header is used, it is passed unaltered along with the filtered data.

#### 3.5 Voltage Regulator

The QF1D512 provides an internal voltage regulator to allow for operation from a single 3.3 V supply. The regulator is stand-alone and its use is optional.

## 4 SOFTWARE

### 4.1 Device Configuration

Before useful data can be output from the QF1D512 it must first be correctly configured. Configuration parameters include the following:

1. Data interface configuration: includes header use and size, and data size
2. Data mode of operation: SPI Normal, Continuous, or Synchronous Serial mode
3. Decimation and averaging configuration (if utilized)
4. FIR filter coefficients.

### 4.2 Quickfilter Development Kit (QF1D512-DK)

The Development Kit is a complete hardware and software combination which allows for rapid development of the QF1D512 configuration parameters for a specific application.

The Quickfilter Design Software tool allows all the necessary parameters to be generated in a quick and user-friendly manner. The user enters the desired characteristics (e.g. sampling rates, type of filter, cut-off frequencies etc.) for each channel and the software generates a configuration file for the device. The configuration file can be immediately downloaded into the QF1D512 on the development board, and the *actual hardware device performance* can be monitored - either in response to a PC-generated noise source or to a user-applied signal. Device configuration parameters can be further adjusted, if necessary, until the optimum system performance is reached.

Once satisfied with the performance the configuration file can be saved for future use, for example to program devices in bulk prior to volume board manufacturing.

## 5 CONFIGURATION INTERFACE

### 5.1 Modes of Operation

The QF1D512 is designed to interface directly with the serial peripheral interface (SPI) of microcontrollers and Digital Signal Processors. The QF1D512 always operates in SPI slave mode where **SDI** is the input serial data, and **SDO** is the output serial data (**FILT\_EN** = 0). **SCLK** is the input serial clock. Default is to capture on rising edge, but this can be changed to capture on falling edge by writing the **CONTROL** register.

In order to address and write to the QF1D512, **CSN** is asserted low. When the device is not selected, data will not be accepted via the serial input pin (**SDI**) and the serial output pin (**SDO**) will remain in a high impedance state.

There are two modes of bus operation for the QF1D512, "configure" mode, and "data" mode. The required mode is selected by writing the **FILT\_EN** bit in the **CONTROL** register (03h).

"Configure" mode is used to set up or change options in the QF1D512. In this mode it is possible to read/write the control registers and the coefficient RAM.

"Data" Mode is used to interface with an ADC or uP and run the FIR filter. When **FILT\_EN** is set high, the function of the **SDO** pin changes from configuration data to filter data. (see DATA INTERFACE above). The format of the **SDO** will match the format of the data coming into the **DIN** pin.

### 5.2 Sending Commands in Filter Mode

To reconfigure the QF1D512 while in the Data mode, it is required to send data on the configuration interface. While all of the configuration registers are accessible while the QF1D512 is in Data mode, the only register that should be accessed is the **CONFIG** register (address 0003h) and only the **FILT\_EN** bit (bit 0) should be modified. Accesses to other registers might result in corrupted filter data or other unpredictable behavior.

In configurations in which the **SDI** and the **DIN** pins have been tied together, allowing for single SPI port data filtering, it is necessary to insure that the incoming data format does not match either the configuration register access format (see Table 4) or the FIR coefficient memory access format (see Table 5) as this may cause unintentional writes to configuration or coefficient memory. In other words, take care to ensure that the most significant byte of the data input does not match either of the WRITE opcodes.



## 6 DATA INTERFACE

### 6.1 Modes of Operation

The QF1D512 is designed to interface directly with a variety of ADC converters. The QF1D512 has three data interface modes.

1. SPI Normal Mode
2. SPI Continuous Mode
3. Synchronous Serial Mode

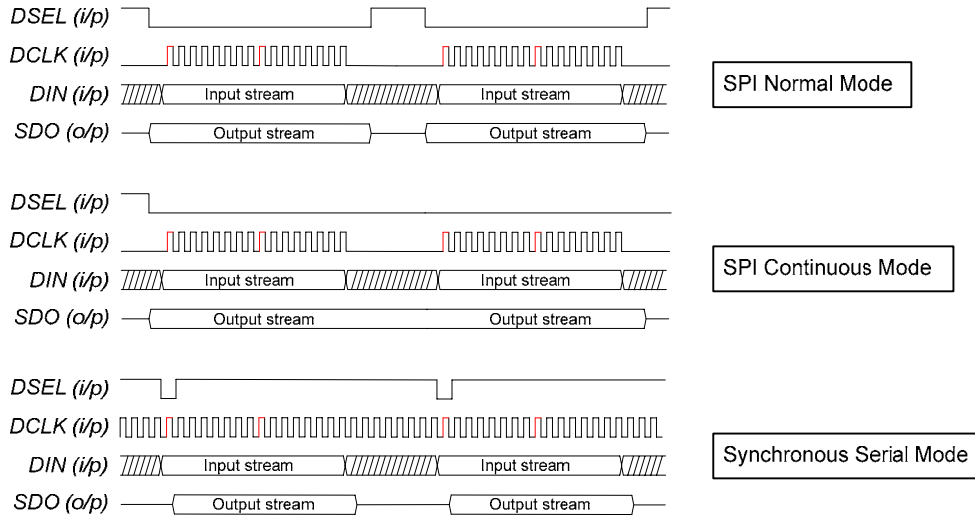

\*\* DSEL active polarity, DCLK idle phase and data sampling/output phase are all programmable

**Figure 3: Serial Data Timing**

The QF1D512 supports both 2's complement and offset binary data formats. The data mode is selected in the DCONFIG register.

The QF1D512 supports data widths in the range of 12 and 24 bits.

The format of the input data stream is specified in the **HD\_OFFSET** (address 0009h), **HD\_SIZE** (address 000Ah), **DATA\_OFFSET** (address 000Dh), and the **DATA\_SIZE** (address 000Eh) registers. These registers set the header offset, header size, data offset, and data size respectively of the individual data sample. This allows for a large number of different data formats. Additionally, if the sample data contains a data valid qualifier, this field can be masked by configuring the **HD\_MASK**, address 000Bh and **HD\_VALUE**, address 000Ch registers. The filtering of the sample will occur only if this value matches **HD\_VALUE**, address 000Ch, otherwise the raw sample data is passed directly through to the SDO pin unfiltered.

The **SDO** output format will match the format of the **DIN** when in **DATA** mode. Any data that is not filtered will be sent out the SDO interface without modification. When averaging and / or down sampling is active, the data rate will be the same as the incoming data rate, but the number of valid samples will be reduced by the averaging / down sampling rate.



## 8 FIR FILTER

### 8.1 Modes of Operation

The QF1D512 filter can implement a symmetric 512-tap FIR filter or a 256-tap asymmetric FIR filter, which is used to define the precise filtering characteristics desired. The filter coefficients are 32 bit wide. The filtering provided by the software may be following types: low-pass, notched low-pass, high-pass, band-pass, dual band-pass, band-stop, and dual band-stop. Currently available filter algorithms include Parks-McClellan and Windowed Sync. User defined filters can also be implemented.

The Quickfilter software allows the user to enter the filter characteristics required and see the predicted performance in terms of frequency and impulse response. Once the desired performance has been attained, the configuration can be downloaded to the QF1D512, and the actual filter performance verified, by using the development kit. The development board can be fed with a white noise source (or other source as desired by the user) and the software can display an FFT of the QF1D512's filter response.

### 8.2 FIR Latency

The delay introduced by the FIR filter is dependent on the number of taps of the filter and the data rate of the samples coming into the FIR filter. The delay is calculated by the following equation:

$$\text{FIR Delay} = (\# \text{ taps} - 1)/2 * 1/f_s$$

For data sampling at a 10 kHz rate, the latency will result in:

512 tap (maximum) filter:	Latency = 25.5ms
100 tap filter:	Latency = 4.95ms

## 9 Voltage Regulator

### 9.1 Mode of Operation

The QF1D512 provides an internal linear voltage regulator to allow for the operation from a single 3.3V supply. To use this feature, the input to the voltage regulator (pin **RVDD33**) is connected to the 3.3V supply. The output (pin **RVDD18**) is connected to the **VDD18** pin. To disable this feature, tie **RVDD33** to Ground and leave the **RVDD18** pin unconnected (or connected to GND).

## 10 CONTROL REGISTERS

### 10.1 Overview

The QF1D512 internal data is separated into configuration registers and coefficient memory.

**Table 2: Register and Memory Format**

Registers	Address Range	Data Size	Write OpCode	Read Opcode
Device Configuration	0x0000 – 0x0018	8 bit	0x82	0x83
FIR Coefficients	0x0000 – 0x00FF	32 bit	0x86	0x87

**Table 3 : Control Registers**

Hex*	Register Name	Description
0000h	<b>TEST_RW</b>	Software Register, Test Reads and Writes
0001h	<b>CHIP_ID</b>	Chip ID Number
0002h	<b>VERSION</b>	Chip Version Number
0003h	<b>CONTROL</b>	Mode Control Register
0004h	<b>DCONFIG</b>	Data Format Control
0005h	<b>FCONFIG</b>	Filter Control and Status
0006h	<b>NUM_TAPS</b>	Number of Taps, lower bits
0007h	<b>NUM_TAPS</b>	Number of Taps, upper bits
0008h	<b>DECIMATE</b>	Down-sampling Rate
0009h	<b>HD_OFFSET</b>	Header Offset
000Ah	<b>HD_SIZE</b>	Header Length
000Bh	<b>HD_MASK</b>	Header Valid Mask
000Ch	<b>HD_VALUE</b>	Header Valid Value
000Dh	<b>DATA_OFFSET</b>	Data Offset
000Eh	<b>DATA_SIZE</b>	Data length
000Fh	<b>TEST</b>	Chip Test Register
0010h	<b>IO_TST</b>	TST Pin Configuration
0011h	<b>IO_RST_N</b>	RST_N Pin Configuration
0012h	<b>IO_DCLK</b>	DCLK Pin Configuration
0013h	<b>IO_DSEL</b>	DSEL Pin Configuration
0014h	<b>IO_DIN</b>	DIN Pin Configuration
0015h	<b>IO_CS_N</b>	CS_N Pin Configuration
0016h	<b>IO_SCLK</b>	SCLK Pin Configuration
0017h	<b>IO_SDI</b>	SDI Pin Configuration
0018h	<b>IO_SDO</b>	SDO Pin Configuration

## 10.2 Configuration Registers

Accessing the configuration registers uses an SPI access as shown below.

**Table 4: Configuration Register Access Format**

	OPCODE	ADDRESS	UNUSED	DATA
Number of bits	8 bits	14 bits	2 bits	8 bits per register*
Write Access	82h	0000h – 0018h	Don't care	00h – FFh
Read Access	83h	0000h – 0018h	Don't care	00h – FFh

Note: \* Multiple registers can be written/read by extending the SPI access cycle.

Listed below are the detailed configuration register definitions.

Note: \* denotes default values

### 00h TEST\_RW (User Register)

	Bit 7	Bit 6	Bit 5	Bit 4	Bit 3	Bit 2	Bit 1	Bit 0
Address 00h	D7	D6	D5	D4	D3	D2	D1	D0

Description: Provided as a blank user byte for the programmer to read and write to as a test. This byte defaults to 0 at power\_\_.

### 01h CHIP\_ID (Chip ID) - READ ONLY

	Bit 7	Bit 6	Bit 5	Bit 4	Bit 3	Bit 2	Bit 1	Bit 0
Address 01h	ID7	ID6	ID5	ID4	ID3	ID2	ID1	ID0

[ID7:ID0] = Identification number of the QF1D512, default = B0h.

Description: This read-only byte contains a number describing the identification of the QF1D512 device.

### 02h VERSION (Version) - READ ONLY

	Bit 7	Bit 6	Bit 5	Bit 4	Bit 3	Bit 2	Bit 1	Bit 0
Address 02h	VER7	VER6	VER5	VER4	VER3	VER2	VER1	VER0

[VER7:VER0] = Version number of the QF1D512, default = 01h.

Description: This read-only byte contains a number describing the version of the QF1D512 device.

### 03h CONTROL (Filter/Pass Through Control)

	Bit 7	Bit 6	Bit 5	Bit 4	Bit 3	Bit 2	Bit 1	Bit 0
Address 03h	X	X	X	X	X	X	DIN_PT	FILT_EN

[FILT\_EN]

\*0 = Configuration mode, SDO pin outputs the configuration register.

1 = Filter mode, SDO pin outputs the signal path data.

Description: Selects the data source of the SDO pin and enable the Signal processing blocks and data path.

[DIN\_PT]

\* 0 = Normal operation, SDO pin outputs the Configuration register or signal path data.

1 = Data pass through, SDO pin outputs the data on the DIN pin

Description: Puts the QF1D512 in Bypass mode.

**04h DCONFIG** (Data Format Control)

	Bit 7	Bit 6	Bit 5	Bit 4	Bit 3	Bit 2	Bit 1	Bit 0
Address 04h	X	X	MODE1	MODE0	FORMAT	DSEL_POL	DCLK_POL	SCLK_POL

[SCLK\_POL]

0 = Input (SDI) Data is captured on the falling edge of SCLK.

\*1 = Input (SDI) Data is captured on the rising edge of SCLK.

Description: Selects the clock edge of SCLK on which the data on the SDI is captured. SDO is output on the opposite edge.

[DCLK\_POL]

0 = DIN is captured on the falling edge of DCLK.

\*1 = DIN is captured on the rising edge of DCLK.

Description: Selects the clock edge of DCLK on which the data on the DIN pin is captured. SDO is output on the opposite edge (Filter mode).

[DSEL\_POL]

\*0 = DSEL is active low.

1 = DSEL is active high.

Description: Selects polarity of the DSEL pin.

[FORMAT]

\*0 = Incoming data format is 2's complement.

1 = Incoming data format is offset binary.

Description: Selects the data format of the incoming data.

[MODE1:MODE0]

\*00 = Input data mode is SPI Normal Mode.

01 = Input data mode is SPI Continuous Mode.

1X = Input data mode is Synchronous serial mode

Description: Selects the data input mode.

**05h FCONFIG** (Filter Control)

	Bit 7	Bit 6	Bit 5	Bit 4	Bit 3	Bit 2	Bit 1	Bit 0
Address 05h	X	X	X	X	X	OVF_FLAG	FIR_FOLD	DEC_EN

[DEC\_EN]

\*0 = Averaging of down-sampled data is disabled.

1 = Averaging of down-sampled data is enabled.

Description: Selects the averaging of down-sampled data.

**[FIR\_FOLD]**

0 = FIR Filter is not folded (asymmetric, 256 taps maximum).

\*1 = FIR Filter is folded (symmetric, 512 taps maximum).

Description: Selects whether the FIR filter is symmetric (folded) or asymmetric.

**[OVF\_FLAG]**

\*0 = FIR filter has not overflowed.

1 = FIR filter has overflowed.

Description: Indicates that the FIR filter has overflowed. To clear, write a '0' to this bit.

**06h NUM\_TAPS (Number of FIR Filter Taps, Lower Bits)**

	Bit 7	Bit 6	Bit 5	Bit 4	Bit 3	Bit 2	Bit 1	Bit 0
Address 06h	NTAP7	NTAP6	NTAP5	NTAP4	NTAP3	NTAP2	NTAP1	NTAP0

**07h NUM\_TAPS (Number of FIR Filter Taps, Upper Bit)**

	Bit 7	Bit 6	Bit 5	Bit 4	Bit 3	Bit 2	Bit 1	Bit 0
Address 07h	X	X	X	X	X	X	X	NTAP8

[NTAP8: NTAP0] = Number of taps in the FIR filter, range from 1 to 512 (0 based numbering), default = 1FFh (512 Taps).

Description: Sets the number of taps in the FIR filter.

**08h DECIMATE (Down-sampling Rate)**

	Bit 7	Bit 6	Bit 5	Bit 4	Bit 3	Bit 2	Bit 1	Bit 0
Address 08h	DEC7	DEC6	DEC5	DEC4	DEC3	DEC2	DEC1	DEC0

[DEC7: DEC0] = Down sampling rate, range from 1 (no down sampling) to 256 (0 based numbering), default = 0h (no down sampling).

Description: Sets the down sampling rate.

**09h HD\_OFFSET (Offset of Header Field)**

	Bit 7	Bit 6	Bit 5	Bit 4	Bit 3	Bit 2	Bit 1	Bit 0
Address 09h	HDOFF7	HDOFF6	HDOFF5	HDOFF4	HDOFF3	HDOFF2	HDOFF1	HDOFF0

[HDOFF 7: HDOFF 0] = Header field offset in bits, range 0 to 255, default = 0h.

Description: Sets the offset in bits in the data word of the header.

**0Ah HD\_SIZE (Size of Header Field)**

	Bit 7	Bit 6	Bit 5	Bit 4	Bit 3	Bit 2	Bit 1	Bit 0
Address 0Ah	X	X	X	X	HDSIZ3	HDSIZ2	HDSIZ1	HDSIZ0

[HDSIZ3: HDSIZ0] = Header field size in bits, range 0 to 8, default = 0h.

Description: Sets the size of the header field.

**0Bh HD\_MASK** (Header Data Valid Mask)

	Bit 7	Bit 6	Bit 5	Bit 4	Bit 3	Bit 2	Bit 1	Bit 0
Address 0Bh	HDMSK7	HDMSK6	HDMSK5	HDMSK4	HDMSK3	HDMSK2	HDMSK1	HDMSK0

[HDMSK 7: HDMSK 0] = Header data valid bits, default = 0h.

Description: Sets the bits of the header which are used to indicate the data valid condition of the sample.

**0Ch HD\_VALUE** (Header Data Valid Value)

	Bit 7	Bit 6	Bit 5	Bit 4	Bit 3	Bit 2	Bit 1	Bit 0
Address 0Ch	HDDV7	HDDV6	HDDV5	HDDV4	HDDV3	HDDV2	HDDV1	HDDV0

[HDDV 7: HDDV 0] = Header data valid bit pattern, default = 0h.

Description: Sets the pattern in the header which indicates that the data is valid. This value has the mask defined in the **HD\_MASK** register (0Bh) applied to it.

**0Dh DATA\_OFFSET** (Offset of Data Field)

	Bit 7	Bit 6	Bit 5	Bit 4	Bit 3	Bit 2	Bit 1	Bit 0
Address 0Dh	DAOFF7	DAOFF6	DAOFF5	DAOFF4	DAOFF3	DAOFF2	DAOFF1	DAOFF0

[DAOFF 7: D DAOFF 0] = Data field offset in bits, range 0 to 255, default = 0h.

Description: Sets the offset to the data field in the incoming data.

**0Eh DATA\_SIZE** (Number of Bits in the Data Field)

	Bit 7	Bit 6	Bit 5	Bit 4	Bit 3	Bit 2	Bit 1	Bit 0
Address 0Eh	X	X	X	DASIZ4	DASIZ3	DASIZ2	DASIZ1	DASIZ0

[DASIZ4: DASIZ0] = Data field size in bits, range 12 to 24 bits, default 10h (16 bits).

Description: Sets the number of bits in the data field. Only values 12 through 24 are valid. Unpredictable results may occur for values outside this range.

**0Fh TEST** (Chip Test Register) – RESERVED Y

	Bit 7	Bit 6	Bit 5	Bit 4	Bit 3	Bit 2	Bit 1	Bit 0
Address 0Fh	X	X	X	X	X	X	X	X

Description: The register is reserved and should not be accessed. Unpredictable results may occur if accessed.

**10h IO\_TDT** (TST Pin Configuration)

	Bit 7	Bit 6	Bit 5	Bit 4	Bit 3	Bit 2	Bit 1	Bit 0
Address 10h	X	X	X	X	X	PU_EN	PD_EN	SMT_EN

[SMT\_EN]

0 = Normal input.

\*1 = Schmitt trigger input.

Description: Enables the Schmitt trigger input on the TST pin.



[PD\_EN]

0 = No pull down resistor on input.

\*1 = 75K Ohm pull down resistor on input.

Description: Enables the pull down resistor on the TST pin.

[PU\_EN]

\*0 = No pull up resistor on input.

1 = 75K Ohm pull up resistor on input.

Description: Enables the pull down resistor on the TST pin.

**11h IO\_RST\_N (RST\_N Pin Configuration)**

	Bit 7	Bit 6	Bit 5	Bit 4	Bit 3	Bit 2	Bit 1	Bit 0
Address 11h	X	X	X	X	X	PU_EN	PD_EN	SMT_EN

[SMT\_EN]

0 = Normal input.

\*1 = Schmitt trigger input.

Description: Enables the Schmitt trigger input on RST\_N pin.

[PD\_EN]

\*0 = No pull down resistor on input.

1 = 75K Ohm pull down resistor on input.

Description: Enables the pull down resistor on the RST\_N pin.

[PU\_EN]

0 = No pull up resistor on input.

\*1 = 75K Ohm pull up resistor on input.

Description: Enables the pull down resistor on the RST\_N pin.

**12h IO\_DCLK (DCLK Pin Configuration)**

	Bit 7	Bit 6	Bit 5	Bit 4	Bit 3	Bit 2	Bit 1	Bit 0
Address 12h	X	X	X	X	X	PU_EN	PD_EN	SMT_EN

[SMT\_EN]

0 = Normal input.

\*1 = Schmitt trigger input.

Description: Enables the Schmitt trigger input on the DCLK pin.

[PD\_EN]

\*0 = No pull down resistor on input.

1 = 75K Ohm pull-down resistor on input.

Description: Enables the pull down resistor on the DCLK pin.

[PU\_EN]

\*0 = No pull up resistor on input.

1 = 75K Ohm pull-up resistor on input.

Description: Enables the pull down resistor on the DCLK pin.

**13h IO\_DSEL (DSEL Pin Configuration)**

	Bit 7	Bit 6	Bit 5	Bit 4	Bit 3	Bit 2	Bit 1	Bit 0
Address 13h	X	X	X	X	X	PU_EN	PD_EN	SMT_EN

[SMT\_EN]

0 = Normal input.

\*1 = Schmitt trigger input.

Description: Enables the Schmitt trigger input on the DSEL pin.

[PD\_EN]

\*0 = No pull down resistor on input.

1 = 75K Ohm pull-down resistor on input.

Description: Enables the pull down resistor on the DSEL pin.

[PU\_EN]

\*0 = No pull up resistor on input.

1 = 75K Ohm pull-up resistor on input.

Description: Enables the pull down resistor on the DSEL pin.

**14h IO\_DIN (DIN Pin Configuration)**

	Bit 7	Bit 6	Bit 5	Bit 4	Bit 3	Bit 2	Bit 1	Bit 0
Address 14h	X	X	X	X	X	PU_EN	PD_EN	SMT_EN

[SMT\_EN]

0 = Normal input.

\*1 = Schmitt trigger input.

Description: Enables the Schmitt trigger input on the DIN pin.

[PD\_EN]

\*0 = No pull down resistor on input.

1 = 75K Ohm pull-down resistor on input.

Description: Enables the pull down resistor on the DIN pin.

[PU\_EN]

\*0 = No pull up resistor on input.

1 = 75K Ohm pull-up resistor on input.

Description: Enables the pull down resistor on the DIN pin.

**15h IO\_CS\_N (CS\_N Pin Configuration)**

	Bit 7	Bit 6	Bit 5	Bit 4	Bit 3	Bit 2	Bit 1	Bit 0
Address 15h	X	X	X	X	X	PU_EN	PD_EN	SMT_EN

**[SMT\_EN]**

0 = Normal input.

\*1 = Schmitt trigger input.

Description: Enables the Schmitt trigger input on the CS\_N pin.

**[PD\_EN]**

\*0 = No pull down resistor on input.

1 = 75K Ohm pull-down resistor on input.

Description: Enables the pull down resistor on the CS\_N pin.

**[PU\_EN]**

0 = No pull up resistor on input.

\*1 = 75K Ohm pull-up resistor on input.

Description: Enables the pull down resistor on the CS\_N pin.

**16h IO\_SCLK (SCLK Pin Configuration)**

	Bit 7	Bit 6	Bit 5	Bit 4	Bit 3	Bit 2	Bit 1	Bit 0
Address 16h	X	X	X	X	X	PU_EN	PD_EN	SMT_EN

**[SMT\_EN]**

0 = Normal input.

\*1 = Schmitt trigger input.

Description: Enables the Schmitt trigger input on the SCLK pin.

**[PD\_EN]**

\*0 = No pull down resistor on input.

1 = 75K Ohm pull-down resistor on input.

Description: Enables the pull down resistor on the SCLK pin.

**[PU\_EN]**

\*0 = No pull up resistor on input.

1 = 75K Ohm pull-up resistor on input.

Description: Enables the pull down resistor on the SCLK pin.

**17h IO\_SDI (SDI Pin Configuration)**

	Bit 7	Bit 6	Bit 5	Bit 4	Bit 3	Bit 2	Bit 1	Bit 0
Address 17h	X	X	X	X	X	PU_EN	PD_EN	SMT_EN

**[SMT\_EN]**

0 = Normal input.

\*1 = Schmitt trigger input.

Description: Enables the Schmitt trigger input on the SDI pin.

**[PD\_EN]**

\*0 = No pull down resistor on input.

1 = 75K Ohm pull-down resistor on input.

Description: Enables the pull down resistor on the SDI pin.

**[PU\_EN]**

\*0 = No pull up resistor on input.

1 = 75K Ohm pull-up resistor on input.

Description: Enables the pull down resistor on the SDI pin.

**18h IO\_SDO (SDO Pin Configuration)**

	Bit 7	Bit 6	Bit 5	Bit 4	Bit 3	Bit 2	Bit 1	Bit 0
Address 18h	X	X	X	X	X	DR2MA	DR4MA	SLEW

**[SLEW]**

\*0 = Slow slew rate.

1 = Fast slew rate.

Description: Selects the slew rate for the SDO pin. Fast slew rate is recommended for SCLK frequencies greater than TBD Hz.

**[DR4MA]**

\*0 = No addition drive current on output driver.

1 = 4 mA addition drive current on output driver.

Description: Configures the output driver for an additional 4 mA of driver current for the SDO pin.

**[DR2MA]**

0 = No addition drive current on output driver.

\*1 = 2 mA addition drive current on output driver.

Description: Configures the output driver for an additional 2 mA of driver current for the SDO pin.

### 10.3 Coefficient Memory

Accessing the coefficient memory uses an SPI access as shown below.

**Table 5: FIR Coefficient Memory Access Format**

	OPCODE	ADDRESS	UNUSED	DATA
Number of bits	8 bits	14 bits	2 bits	32 bits per memory location*
Write Access	86h	0000h – 00FFh	Don't care	0000h – FFFFh
Read Access	87h	0000h – 00FFh	Don't care	0000h – FFFFh

Note: \* Multiple memory locations can be written/read by extending the SPI access cycle.

**0000h – 0400h COEF\_RAM (FIR Filter Coefficient Memory)**

	Bit 31 – Bit 0
Address 0000h – 00FFh	Data 31 – Data 0

Description: FIR filter coefficient memory.

## 11 Operating Mode Configurations

### 11.1 SPI FIR Coprocessor Mode

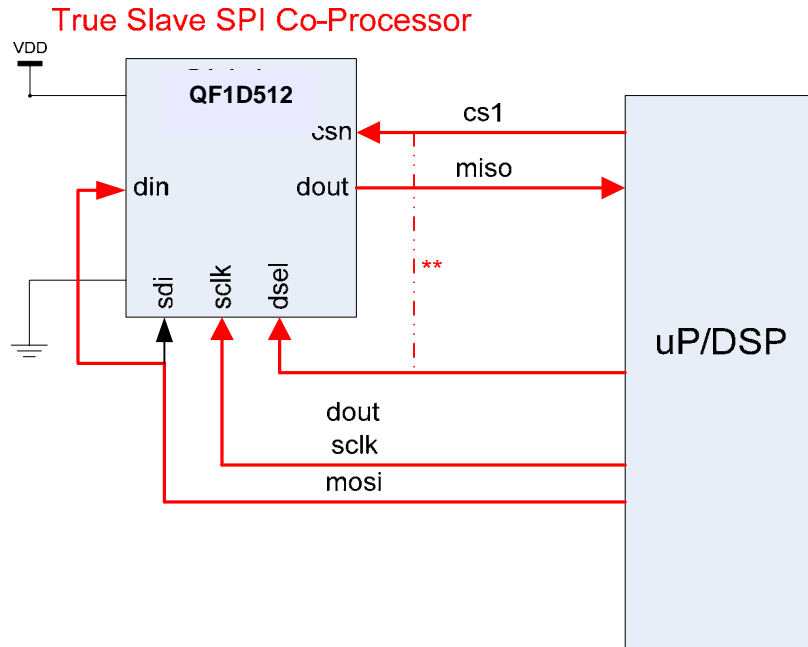

\*\* Can use a single CS w/ command byte overhead

Figure 6: SPI FIR Coprocessor Mode

### 11.2 Inline Normal SPI Mode

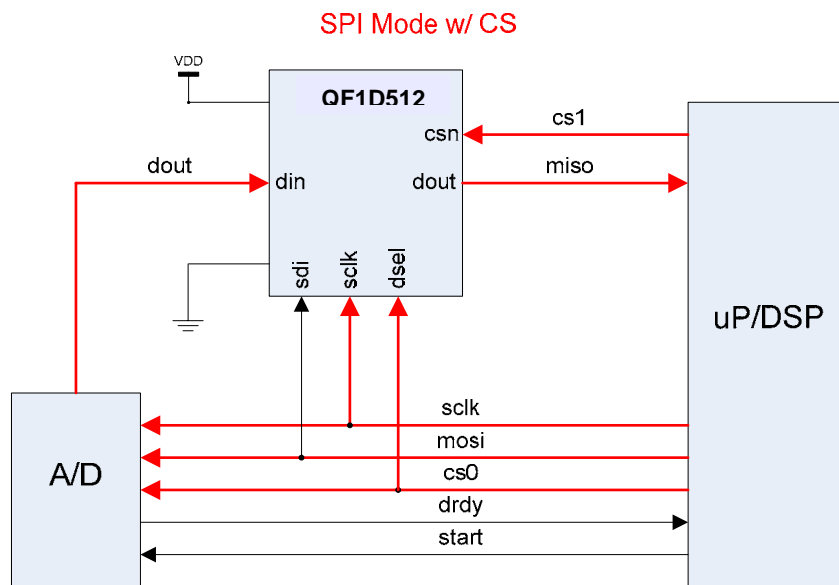

Figure 7 : Inline Normal SPI Mode

### 11.3 Inline Continuous SPI Mode

Continuous SPI Mode w/ CS tied to GND

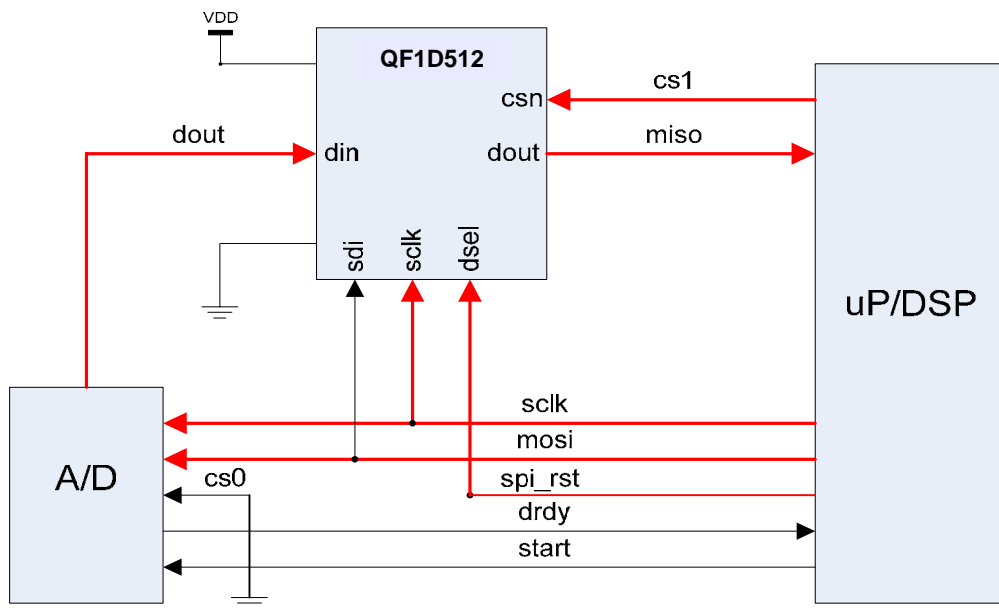

Figure 8 : Inline Continuous SPI Mode

### 11.4 Inline Synchronous Serial Mode

Sync Serial : uP clock slave

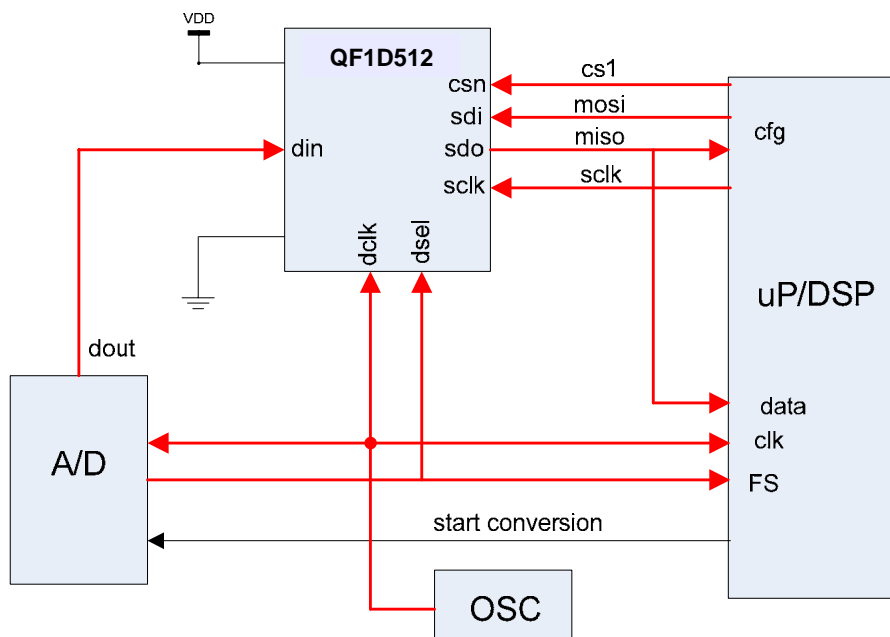

Figure 9 : Inline Synchronous Serial Mode

## 12 Packaging Information

3 x 3 x 0.9mm, VQFN 16, 0.8 mm Pull Back Lead (JEDEC)

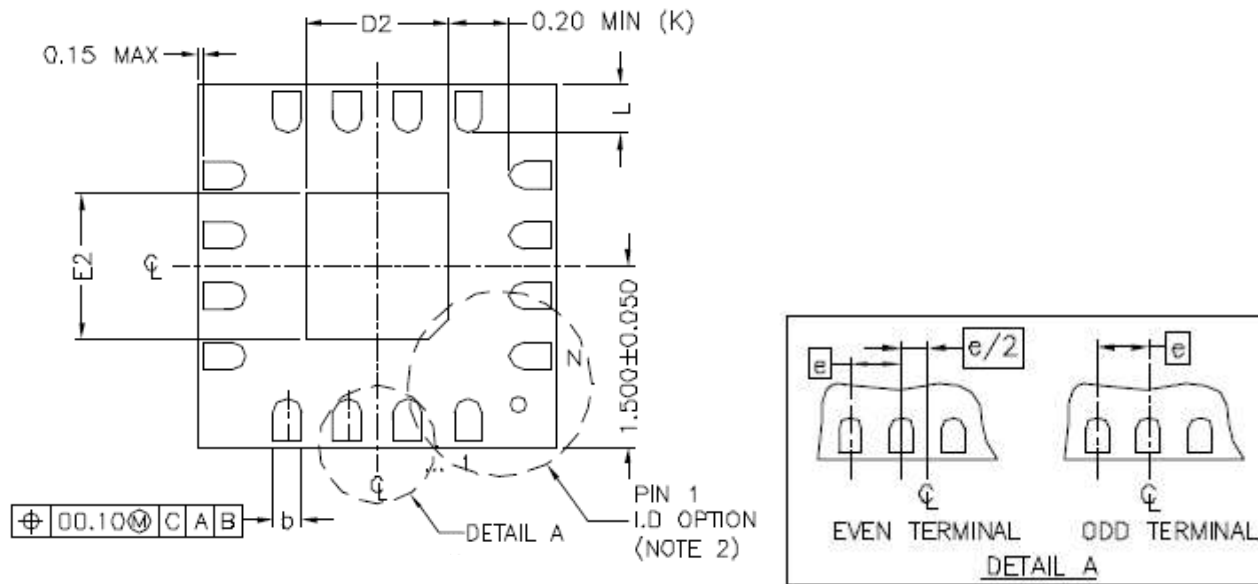

Figure 10: VQFN 16, Bottom View

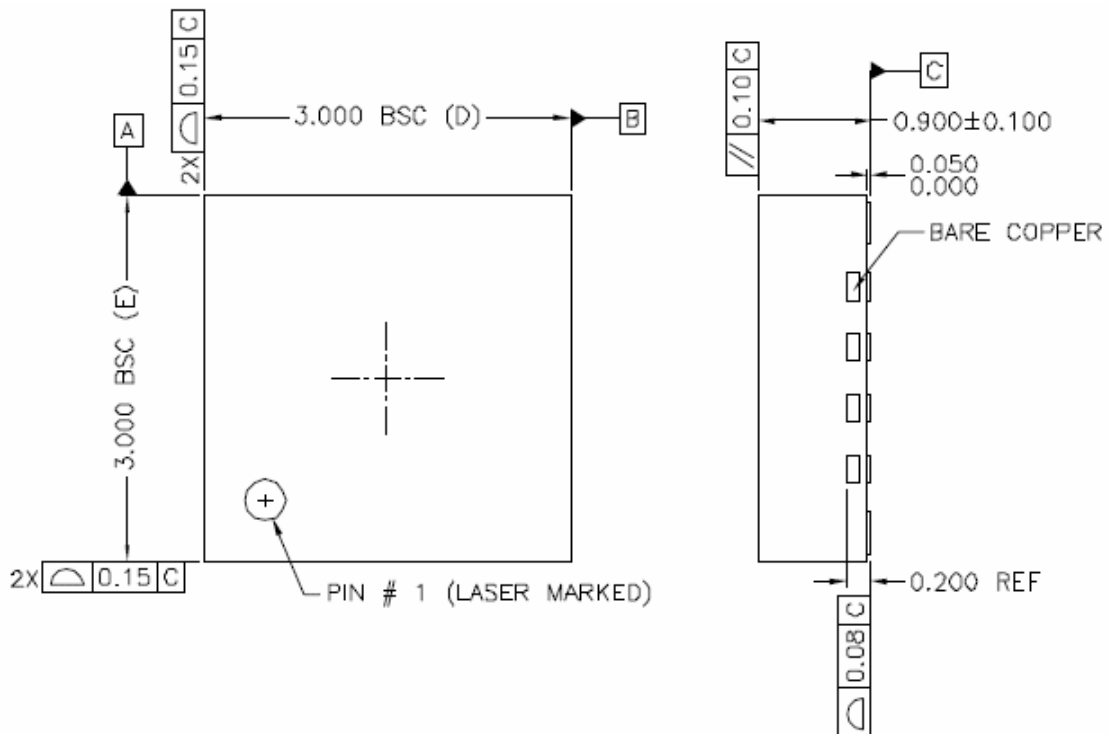

Figure 11: VQFN 16, Top/Side View



**Table 6: VQFN 16, Dimensions**

SYMBOL \ VARIATION	BB		
	MIN	NCM	MAX
e	0.50 BSC		
b	0.18	0.23	0.30
E2	1.60	1.70	1.80
D2	1.60	1.70	1.80
L	0.35	0.40	0.45
N	16 LD		
ND	4		
NE	4		
JEDEC VARIATION	VEED-4		
INTERNAL FEATURE	STANDARD		
LF P/N	PPF	16-016-003	
	AG SPOT	N/A	
	AG RING	△ 16-016-091	
PKG CODE	VQ 016		

**Notes:**

1. Dimensions are in millimeters.
2. Interpret dimensions and tolerance per ASME Y14.5M-1994

**13 List of Figures**

FIGURE 1: 16 PIN QFN PACKAGE PIN OUT ..... 6  
FIGURE 2: FUNCTIONAL BLOCK DIAGRAM..... 7  
FIGURE 3: SERIAL DATA TIMING ..... 9  
FIGURE 4: DATA HEADER EXAMPLE ..... 10  
FIGURE 5: AVERAGING /DOWN-SAMPLER BLOCK DIAGRAM ..... 10  
FIGURE 6: SPI FIR COPROCESSOR MODE..... 22  
FIGURE 7 : INLINE NORMAL SPI MODE..... 22  
FIGURE 8 : INLINE CONTINUOUS SPI MODE..... 23  
FIGURE 9 : INLINE SYNCHRONOUS SERIAL MODE ..... 23  
FIGURE 10: VQFN 16, BOTTOM VIEW ..... 24  
FIGURE 11: VQFN 16, TOP/SIDE VIEW ..... 24

**14 List of Tables**

TABLE 1: PIN DESCRIPTIONS..... 6  
TABLE 2: REGISTER AND MEMORY FORMAT ..... 12  
TABLE 3 : CONTROL REGISTERS..... 12  
TABLE 4: CONFIGURATION REGISTER ACCESS FORMAT..... 13  
TABLE 5: FIR COEFFICIENT MEMORY ACCESS FORMAT..... 21  
TABLE 6: VQFN 16, DIMENSIONS..... 25

The contents of this document are provided in connection with Quickfilter Technologies, Inc. products. Quickfilter makes no representations or warranties with respect to the accuracy or completeness of the contents of this publication and reserves the right to make changes to specifications and product descriptions at any time without notice. No license, whether express, implied, arising by estoppel or otherwise, to any intellectual property rights is granted by this publication. Except as set forth in Quickfilter's Standard Terms and Conditions of Sale, Quickfilter assumes no liability whatsoever, and disclaims any express or implied warranty, relating to its products including, but not limited to, the implied warranty of merchantability, fitness for a particular purpose, or infringement of any intellectual property right. Quickfilter's products are not designed, intended, authorized or warranted for use as components in systems intended for surgical implant into the body, or in other applications intended to support or sustain life, or in any other application in which the failure of Quickfilter's product could create a situation where personal injury, death, or severe property or environmental damage may occur. Quickfilter reserves the right to discontinue or make changes to its products at any time without notice.

© 2006 Quickfilter Technologies, Inc.  
All rights reserved.

1024 S. Greenville Ave  
Suite 100  
Allen, TX 75002-3344

Telephone: (214) 547-0460  
Fax: (214) 547-0481

For inquiries, please contact Quickfilter at the above address,

Or visit our website:  
<http://www.quickfiltertech.com>

Quickfilter, the Quickfilter logo and "Programmable Signal Converter", and combinations thereof, are trademarks of Quickfilter Technologies, Inc. Other product names used in this publication are for identification purposes only and may be trademarks of their respective companies.