

RC4194

Dual Tracking Voltage Regulators

Features

- Simultaneously adjustable outputs with one resistor to $\pm 42V$
- Load current – $\pm 200\text{ mA}$ with 0.04% load regulation
- Internal thermal shutdown at $T_J = +175^\circ\text{C}$
- External balance for $\pm V_{OUT}$ unbalancing
- 3W power dissipations

Description

The RC/RM4194 are dual polarity tracking regulators designed to provide balanced or unbalanced positive and negative output voltages at currents to 200 mA. A single external resistor adjustment can be used to change both outputs between the limits of $\pm 50\text{ mV}$ and $\pm 42V$.

These devices are designed for local “on-card” regulation, eliminating distribution problems associated with single-point regulation. To simplify application the regulators require a minimum number of external parts.

The device is available in three package types to accommodate various power requirements. The K (TO-66) power package can dissipate up to 3W at $T_A = +25^\circ\text{C}$. The D 14-pin dual in-line will dissipate up to 1W and the N 14-pin dual in-line will dissipate up to 625 mW.

Block Diagram

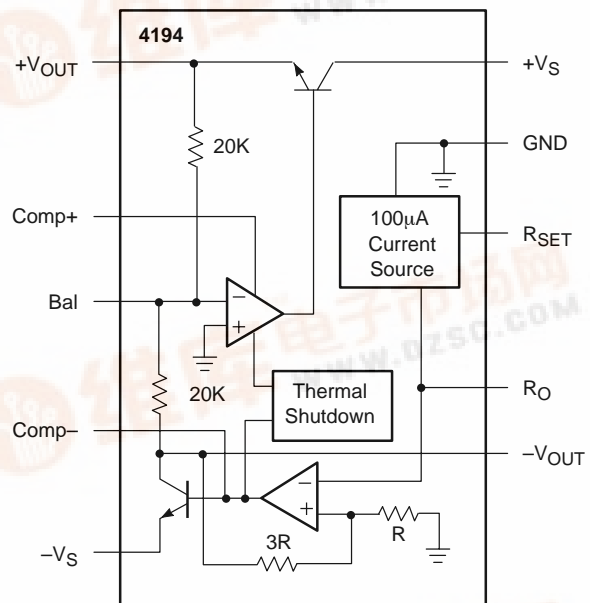

65-4194-01

Pin Assignments

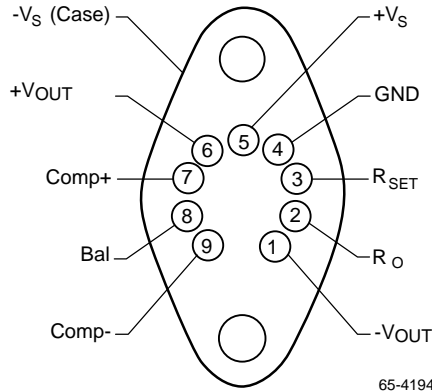

65-4194-02

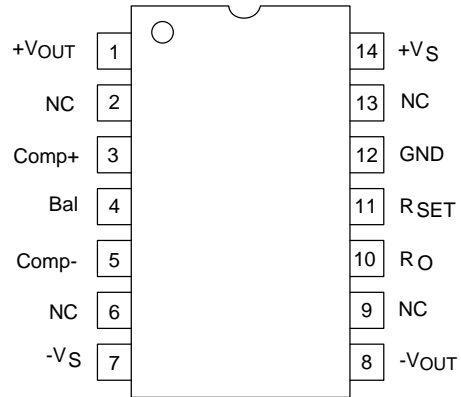

65-4194-03

Absolute Maximum Ratings

(beyond which the device may be damaged)¹

Parameter		Min	Typ	Max	Units
Supply Voltage	RC4194			±35	V
	RM4194			±45	V
Supply Input to Output Voltage Differential	RC4194			±35	V
	RM4194			±45	V
Load Current	PDIP			100	mA
	CerDIP			150	mA
	TO-66 Metal Can			250	mA
P _{DTA} < 50°C	PDIP			468	mW
	CerDIP			1042	mW
	TO-66 Metal Can			2381	mW
Operating Temperature (T _j)	RC4194	0		70	°C
	RM4194	-55		125	°C
Storage Temperature		-65		150	°C
Junction Temperature	PDIP			125	°C
	CerDIP			175	°C
	TO-66 Metal Can			150	°C
Lead Soldering Temperature (60 seconds)				300	°C
For T _A > 50°C Derate at	TO-66 Metal Can		23.81		mW/°C
	PDIP		6.25		mW/°C
	CerDIP		8.38		mW/°C

Note:

1. Functional operation under any of these conditions is NOT implied.

Operating Conditions

Parameter		Min	Typ	Max	Units
θ_{JC}	Thermal Resistance	CerDIP	60		$^{\circ}\text{C}/\text{W}$
		TO-66 Metal Can	7		$^{\circ}\text{C}/\text{W}$
θ_{JA}	Thermal Resistance	PDIP	160		$^{\circ}\text{C}/\text{W}$
		CerDIP	120		$^{\circ}\text{C}/\text{W}$
		TO-66 Metal Can	42		$^{\circ}\text{C}/\text{W}$

Electrical Characteristics

($\pm 5 \leq V_{OUT} \leq V_{MAX}$; $-V_{IN} \leq -8\text{V}$; $I_L = \pm 1\text{mA}$; RM4194: $-55^{\circ}\text{C} \leq T_j \leq +125^{\circ}\text{C}$; RC4194: $0^{\circ}\text{C} \leq T_j \leq +70^{\circ}\text{C}$ unless otherwise specified)

Parameters	Test Conditions	Min	Typ	Max	Units
Line Regulation	$\Delta V_S = 0.1 V_{IN}$		0.04	0.1	% V_{OUT}
Load Regulation ¹	4194K: $I_L < 200\text{ mA}$ 4194D: $I_L < 100\text{ mA}$ $\pm V_S = \pm (V_{OUT} + 5)\text{V}$		0.002	0.004	% V_{OUT}/I_L (mA)
Output Voltage Drift With Temperature ²					
Positive Output	$V_{OUT} = \pm 5\text{V}$		0.002	0.015	%/ $^{\circ}\text{C}$
Negative Output	$V_{OUT} = \pm 5\text{V}$		0.003	0.015	%/ $^{\circ}\text{C}$
Supply Current ³ (Positive)	$V_S = \pm V_{MAX}$, $V_{OUT} = 0\text{V}$, $I_L = 0\text{ mA}$		+0.8	+2.5	mA
Supply Current ⁴ (Negative)	$V_S = \pm V_{MAX}$, $V_{OUT} = 0\text{V}$, $I_L = 0\text{ mA}$		-1.8	-4.0	mA
Supply Voltage	RM4194	± 9.5		± 45	V
	RC4194	± 9.5		± 35	V
Output Voltage Scale Factor	$R_{SET} = 71.5\text{ k}\Omega$, $T_j = +25^{\circ}\text{C}$, $V_S = \pm V_{MAX}$	2.38	2.5	2.62	$\text{k}\Omega/\text{V}$
Output Voltage Range	RM4194: $R_{SET} = 71.5\text{ k}\Omega$, $I_L = 25\text{ mA}$	0.05		± 42	V
	RC4194: $R_{SET} = 71.5\text{ k}\Omega$, $I_L = 25\text{ mA}$	0.05		± 42	V
Output Voltage Tracking			± 0.4	± 2.0	%
Ripple Rejection	$F = 120\text{ Hz}$, $T_j = +25^{\circ}\text{C}$		70		dB
Input-Output Voltage Differential	$I_L = 50\text{ mA}$, $T_j = +25^{\circ}\text{C}$	3.0			V
Short Circuit Current	$V_S = \pm 30\text{V}$, $T_j = +25^{\circ}\text{C}$		300		mA
Output Noise Voltage	$C_L = 4.7\text{ }\mu\text{F}$, $V_{OUT} = \pm 15\text{V}$, $F = 10\text{ Hz to }100\text{ kHz}$		250		μV_{RMS}
Internal Thermal Shutdown			175		$^{\circ}\text{C}$

Notes:

1. Measured as $\left(\frac{\Delta V_{OUT}}{V_{OUT}} \times 100\%\right) \text{ } \S I_L \text{ (mA)}$

2. Output voltage temperature drift guaranteed by design.

3. The current drain will increase by $50\mu\text{A}/V_{OUT}$ on positive side and $100\mu\text{A}/V_{OUT}$ on negative side.

4. The specifications above apply for the given junction temperatures since pulse test conditions are used.

Typical Performance Characteristics

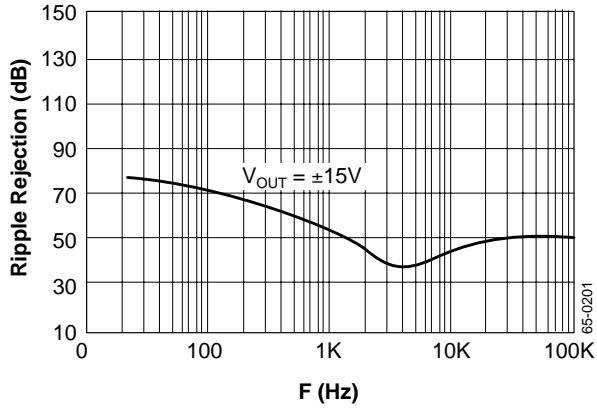

Figure 1. Ripple Rejection vs. Frequency

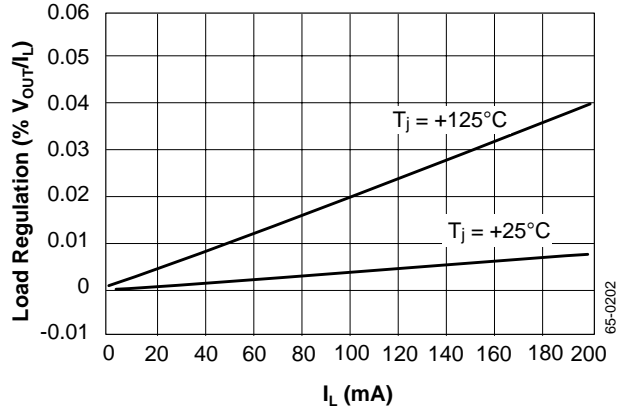
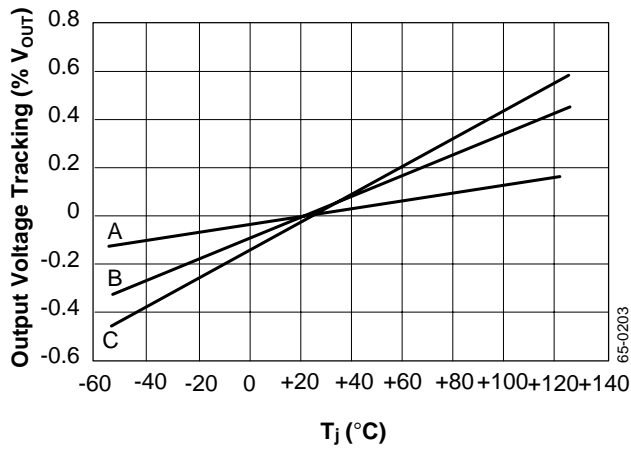

Figure 2. Load Regulation vs. Load Current



A = % Tracking of V_{OUT}
 B = T.C. for Positive Regulator
 C = T.C. for Negative Regulator

Figure 3. Output Voltage Tracking vs. Temperature

Typical Applications (continued)

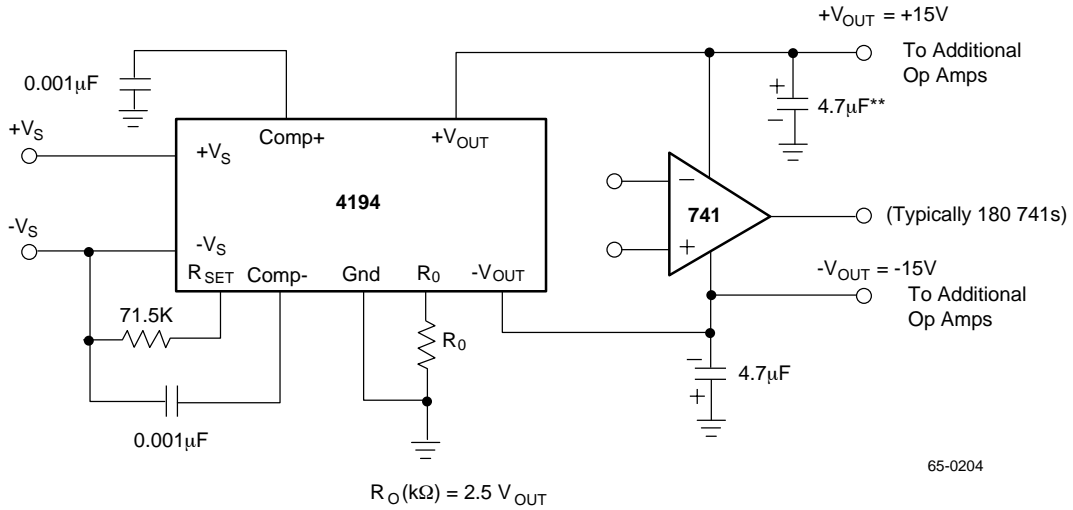

65-0204

Figure 6. Balanced Output Voltage — Op Amp Application

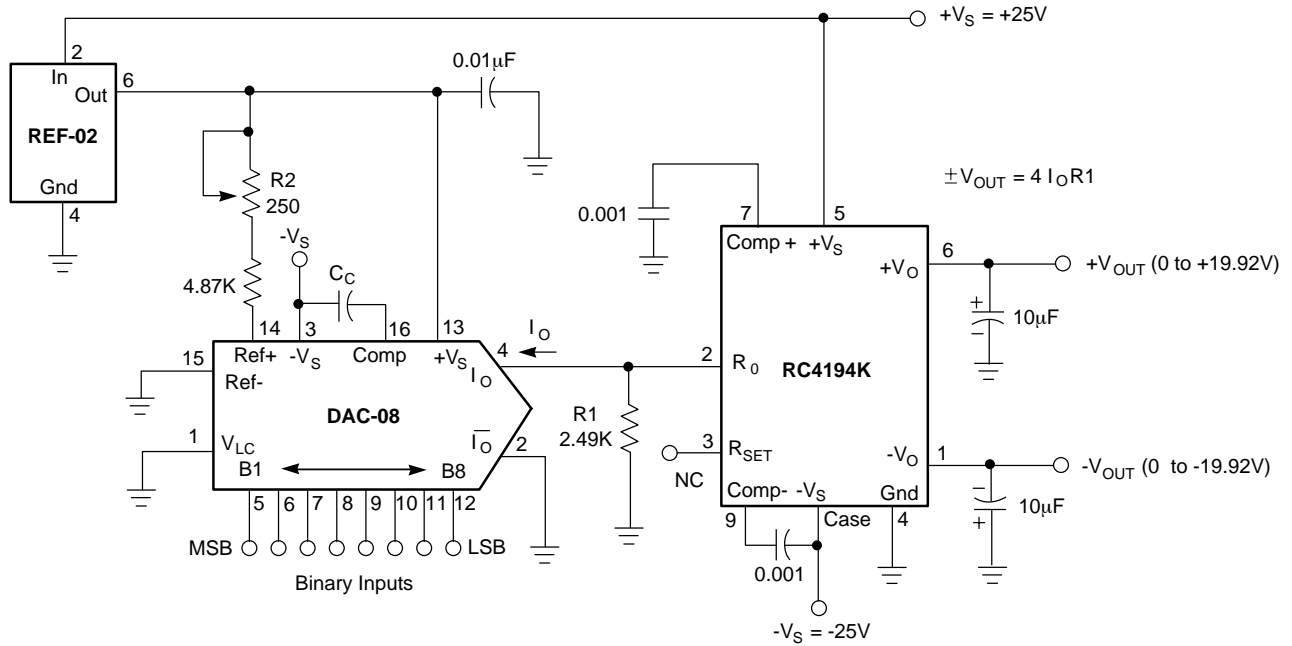

Adjust R2 for -19.92V at $-V_{OUT}$ with all "1s" at binary inputs, then optionally adjust R3 for +19.92V at $+V_{OUT}$

65-1725

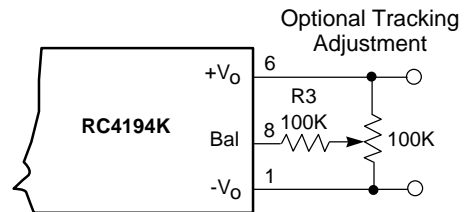

Figure 7. Digitally Controlled Dual 200 mA Voltage Regulator

RC4194 Switchable Power Supply

The outputs of the RC4194 can be simultaneously switched on or off under logic control as shown in Figure 8. In the “off” state, the outputs will be forced to a minimum voltage, or about ± 20 mV, rather than becoming open-circuit. The turn-on time, with the outputs programmed to ± 12 V, is approximately $200 \mu\text{s}$. This circuit works by forcing the R0 pin to ground with an analog switch.

Refer to the RC4194 internal schematic diagram. A reference voltage that regulates with respect to $-V_S$ is generated at the RSET pin by the zener diode Q12 and the buffer circuit of Q11 and Q13. When the external 71.5k RSET resistor is connected between the RSET pin and $-V_S$, a precision current of $100 \mu\text{A}$ is generated which then flows into Q13’s collector. Since Q13’s collector is tied to the R0 pin, the $100 \mu\text{A}$ current will develop a ground-referenced voltage drop proportional to the value of R0, which is then amplified by the internal error amplifier. When the analog switch in Figure 8 turns on, it effectively shorts out R0 and causes 0V to be applied to the error amplifier. The output voltage in the off state will be approximately ± 20 mV. If a higher value (50 to 100 mV) is acceptable, then the DG201 analog switch can be replaced with a low-cost small signal transistor, as shown in the alternate switch configuration.

Compensation

For most applications, the following compensation technique is sufficient. The positive regulator section of the RC4194 is compensated by a $0.001 \mu\text{F}$ ceramic disc capacitor from the Comp+ terminal to ground. The negative regulator requires compensation at two points. The first is the Comp- pin, which should have $0.001 \mu\text{F}$ to the $-V_S$ pin, or case. A ceramic disc is ideal here. The second compensation point for the negative side is the $-V_{\text{OUT}}$ terminal, which ideally should be a $4.7 \mu\text{F}$ solid tantalum capacitor with enough reserve voltage capacity to avoid the momentary shorting and reforming which can occur with tantalum caps. For systems where the cost of a solid tantalum capacitor cannot be justified, it is usually sufficient to use an aluminum capacitor with a $0.03 \mu\text{F}$ ceramic disc in parallel to bypass high frequencies. In addition, if the rectifier filter capacitors have poor high frequency characteristics (like aluminum electrolytics) or if any impedance is in series with the $+V_S$ and $-V_S$ terminals, it is necessary to bypass these two points with $0.01 \mu\text{F}$ ceramic disc capacitors. Just as with monolithic op amps, some applications may not require these bypass caps, but if in doubt, be sure to include them.

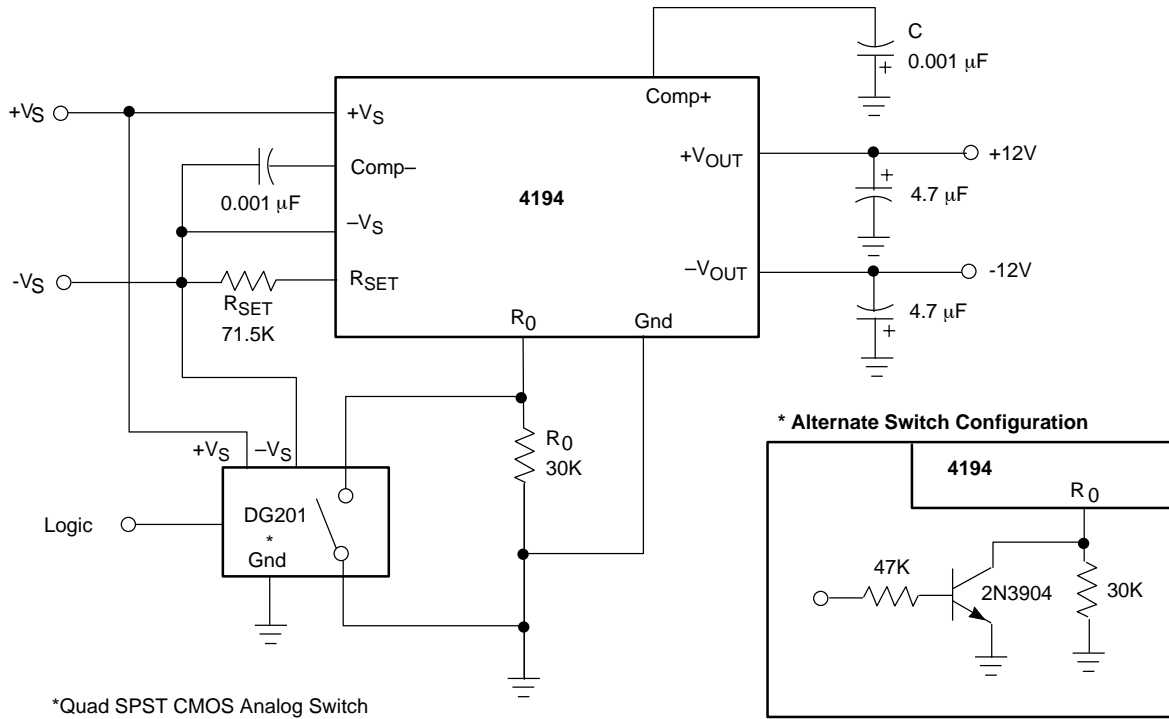

65-4083

Figure 8. ± 12 V Switchable Power Supply

All compensation and bypass caps should have short leads, solid grounds, and be located as close to the 4194 as possible. Refer to Figure 9 for recommended compensation circuitry.

Protection

In systems using monolithic voltage regulators, a number of conditions can exist which, left uncorrected, will destroy the regulator. Fortunately, regulators can easily be protected against these potentially destructive conditions. Monolithic regulators can be destroyed by any reversal of input or output voltage polarity, or if the input voltage drops below the output voltage in magnitude. These conditions can be caused by inductive loads at the inputs or outputs of the regulator. Other problems are caused by heavy loads at the unregulated inputs to the regulator, which might cause the input voltage to drop below the output voltage at turn-off. If any of the preceding problem conditions are present in your system, it is recommended that you protect the regulator using diodes. These diodes should be high speed types capable of handling large current surges. Figure 10 shows all six of the possible protection diodes. The diodes at the inputs and outputs prevent voltages at those points from becoming reversed. Diodes from outputs to inputs prevent the output voltage from exceeding the input voltage. Chances are that the system under consideration will not require all six diodes, but if in doubt, be sure to include them.

Brownout Protection

The RC4194 is one of the most easily applied and trouble-free monolithic ICs available. When used within the data sheet ratings (package power dissipation, maximum output current, minimum and maximum input voltages) it provides the most cost-effective source of regulated $\pm 15V$ for powering linear ICs.

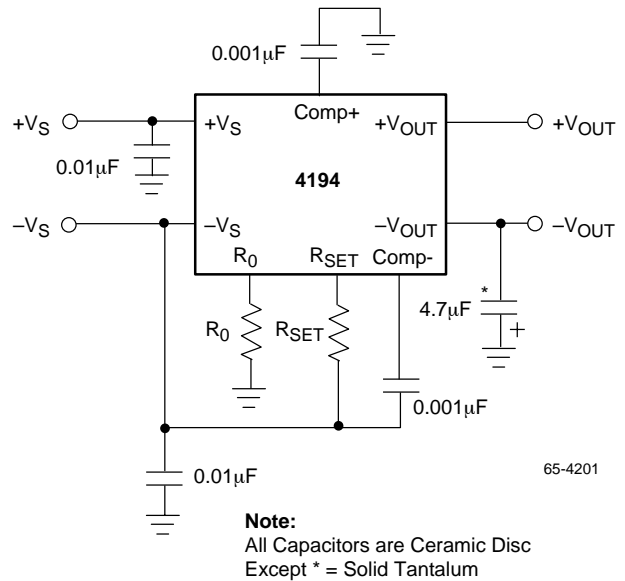

Figure 9. RC4194 Recommended Compensation

Sometimes occasions arise in which the RC4194 ratings must be exceeded. One example is the “brownout.” During a brownout, line voltages may be reduced to as low as 75 VRMS, causing the input voltage to the RC4194 to drop below the minimum dropout voltage. When this happens, the negative output voltage can go to positive. The maximum amount of current available is approximately 5 mA.

In general this is not enough current to damage most ICs which the RC4194 might be supplying, but it is a potentially destructive condition. Fortunately, it is easy to protect against. As shown in the typical application circuit in Figure 11, a diode, D, can be connected to the negative output.

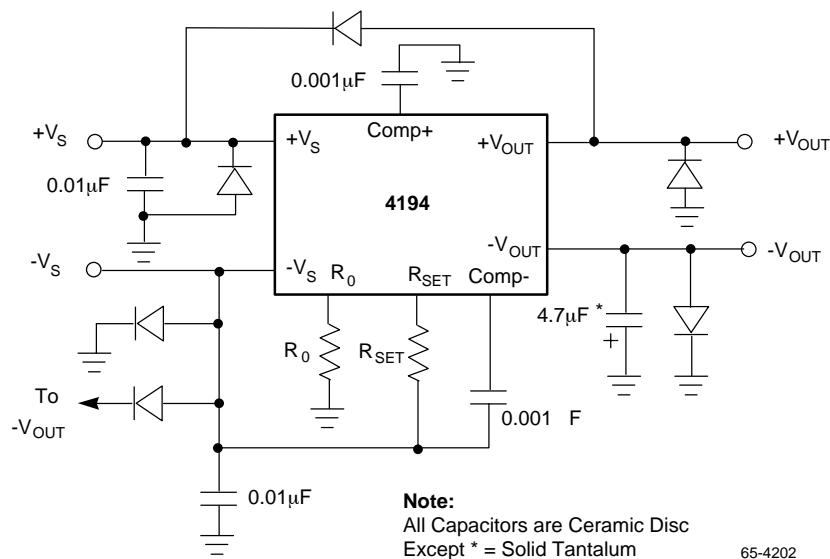

Figure 10. RC4194 Regulator Showing All Protective Diodes

If a small signal silicon diode is used, it will clamp the negative output voltage at about +0.55V. A Schottky barrier or germanium device would clamp the voltage at about +0.3V. Another cure which will keep the negative output negative at all times is the 1 mΩ resistor connected between the +15V output and the Comp- terminal. This resistor will then supply drive to the negative output transistor, causing it to saturate to -1V during the brownout.

Heatsinking

Voltage Regulators are power devices which are used in a wide range of applications.

When operating these devices near their extremes of load current, ambient temperature and input-output differential, consideration of package dissipation becomes important to avoid thermal shutdown at 175°C. The RC4194 has this feature to prevent damage to the device. It typically starts affecting load regulation approximately 2°C below 175°C. To avoid shutdown, some form of heatsinking should be used or one of the above operating conditions would need to be derated.*

The following is the basic equation for junction temperature:

$$T_J = T_A + P_D \theta_{J-A}$$

Equation 1

where

T_J = junction temperature (°C)

T_A = ambient air temperature (°C)

P_D = power dissipated by device (W)

θ_{J-A} = thermal resistance from junction to ambient air (°C/W)

The power dissipated by the voltage regulator can be detailed as follows:

$$P_D = (V_{IN} - V_{OUT}) \times I_O + V_{IN} \times I_Q$$

Equation 2

where

V_{IN} = input voltage

V_{OUT} = regulated output voltage

I_O = load current

I_Q = quiescent current drain

Let's look at an application where a user is trying to determine whether the RC4194 in a high temperature environment will need a heatsink.

Given:

$$T_J \text{ at thermal shutdown} = 150^\circ\text{C}$$

$$T_A = 125^\circ\text{C}$$

$$\theta_{J-A} = 41.6^\circ\text{C/W, K (TO-66) pkg.}$$

$$V_{IN} = 40\text{V}$$

$$V_{OUT} = 30\text{V}$$

$$I_Q = 1 \text{ mA} + 75 \mu\text{A}/V_{OUT} \times 30\text{V} \\ = 3.25 \text{ mA}^*$$

$$\theta_{J-A} = \frac{T_J - T_A}{P_D}$$

$$P_D = \frac{T_J - T_A}{\theta_{J-A}}$$

$$= (V_{IN} - V_{OUT}) \times I_O + V_{IN} \times I_Q$$

Solve for I_O ,

$$I_O = \frac{T_J - T_A}{\theta_{J-A}(V_{IN} - V_{OUT})} - \frac{V_{IN} \times I_Q}{(V_{IN} - V_{OUT})}$$

$$I_O = \frac{150^\circ\text{C} - 125^\circ\text{C}}{41.6^\circ\text{C/W} \times 10\text{V}} - \frac{40 \times 3.25 \times 10^{-3}}{10}$$

$$= 60 \text{ mA} - 13 \text{ mA} \sim 47 \text{ mA}$$

If this supply current does not provide at least a 10% margin under worst case load conditions, heatsinking should be employed. If reliability is of prime importance, the multiple regulator approach should be considered.

In Equation 1, θ_{J-A} can be broken into the following components:

$$\theta_{J-A} = \theta_{J-C} + \theta_{C-S} + \theta_{S-A}$$

where

θ_{J-C} = junction-to-case thermal resistance

θ_{C-S} = case-to-heatsink thermal resistance

θ_{S-A} = heatsink-to-ambient thermal resistance

*The current drain will increase by 50μA/V_{OUT} on positive side and 100μA/V_{OUT} on negative side

In the above example, let's say that the user's load current is 200 mA and he wants to calculate the combined θ_{C-S} and θ_{S-A} he needs:

Given: $I_O = 200$ mA,

$$\theta_{J-A} = \frac{T_J - T_A}{(V_{IN} - V_{OUT}) \times I_O + V_{IN} \times I_Q}$$

$$= \frac{50^\circ\text{C} - 125^\circ\text{C}}{10\text{V} \times 200\text{mA} + 40 \times 3.25 \times 10^{-3}}$$

$$= 11.75^\circ\text{C/W}$$

Given $\theta_{J-C} = 7.15^\circ\text{C/W}$ for the 4194 in the K package,

$$\theta_{C-S} + \theta_{S-A} = 11.75^\circ\text{C/W} - 7.15^\circ\text{C/W}$$

$$= 4.6^\circ\text{C/W}$$

When using heatsink compound with a metal-to-metal interface, a typical $\theta_{C-S} = 0.5^\circ\text{C/W}$ for the K package. The remaining θ_{S-A} of approximately 4°C/W is a large enough thermal resistance to be easily provided by a number of heatsinks currently available. Table 1 is a brief selection guide to heatsink manufacturers.

Table 1. Commercial Heatsink Selection Guide

No attempt has been made to provide a complete list of all heatsink manufacturers. This list is only representative.

θ_{S-A}^1 (°C/W)	Manufacturer/Series or Part Number
TO-66 Package	
0.31 – 1.0	Thermalloy — 6441, 6443, 6450, 6470, 6560, 6590, 6660, 6690
1.0 – 3.0	Wakefield — 641
	Thermalloy — 6123, 6135, 6169, 6306, 6401, 6403, 6421, 6423, 6427, 6442, 6463, 6500
3.0 – 5.0	Wakefield — 621, 623
	Thermalloy — 6606, 6129, 6141, 6303
	IERC — HP
	Staver — V3-3-2
5.0 – 7.0	Wakefield — 690
	Thermalloy — 6002, 6003, 6004, 6005, 6052, 6053, 6054, 6176, 6301
	IERC — LB
	Staver — V3-5-2
7.0 – 10.0	Wakefield — 672
	Thermalloy — 6001, 6016, 6051, 6105, 6601
	IERC — LA, uP
	Staver — V1-3, V1-5, V3-3, V3-5, V3-7
10.0 – 25.0	Thermalloy — 6-13, 6014, 6015, 6103, 6104, 6105, 6117
Dual In-line Package	
20	Thermalloy — 6007
30	Thermalloy — 6010
32	Thermalloy — 6011
34	Thermalloy — 6012
45	IERC — LI
60	Wakefield — 650, 651

Staver Co., Inc.: 41-51 N Saxon Ave., Bay Shore, NY 11706

IERC: 135 W Magnolia Blvd., Burbank, CA 91502

Thermalloy: P.O. Box 34829, 2021 W Valley View Ln., Dallas, TX

Wakefield Engin Ind: Wakefield, MA 01880

* All values are typical as given by manufacturer or as determined from characteristic curves supplied by manufacturer.

Simplified Schematic Diagram

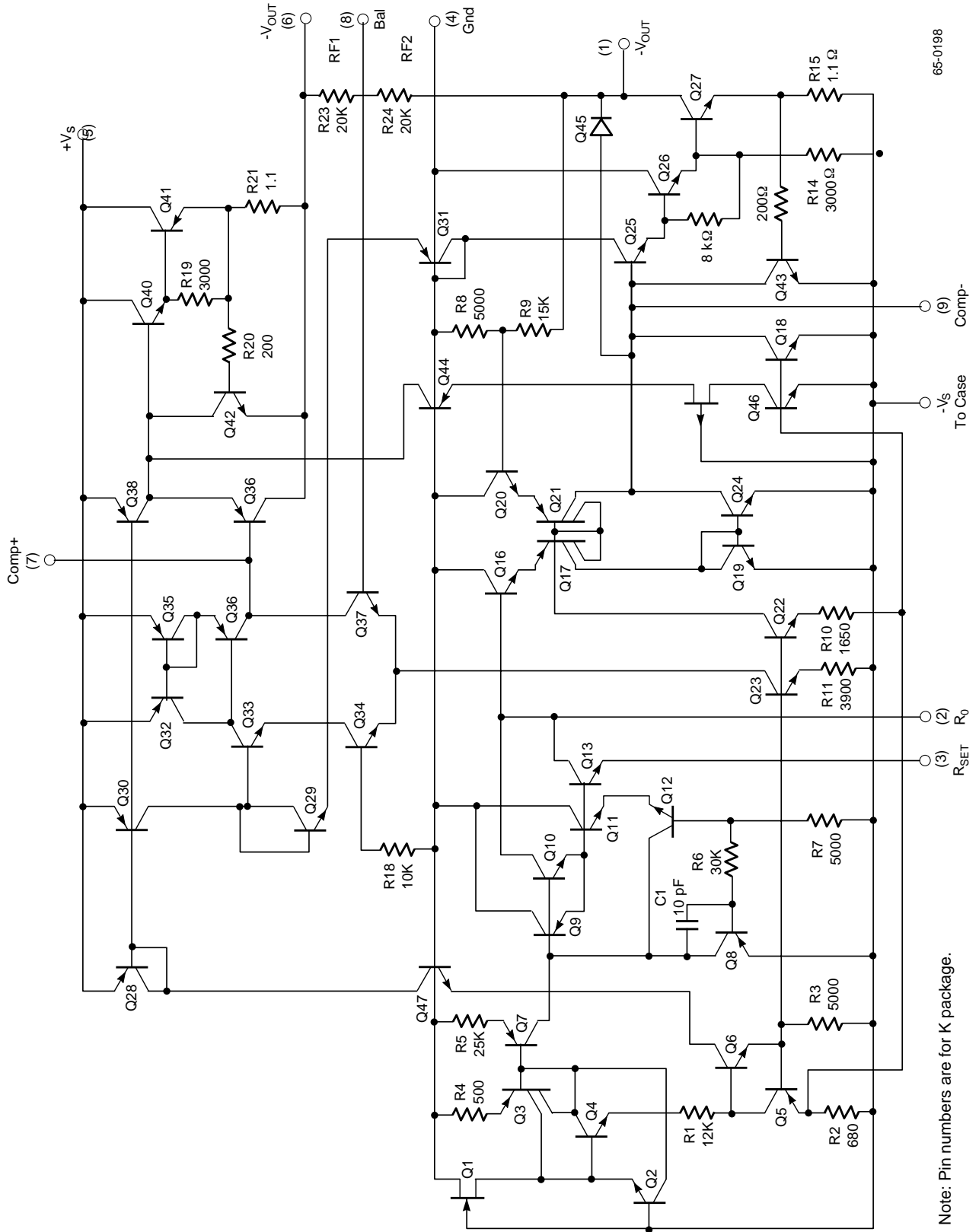

Note: Pin numbers are for K package.

Mechanical Dimensions

9-Lead Metal Can IC Header Package

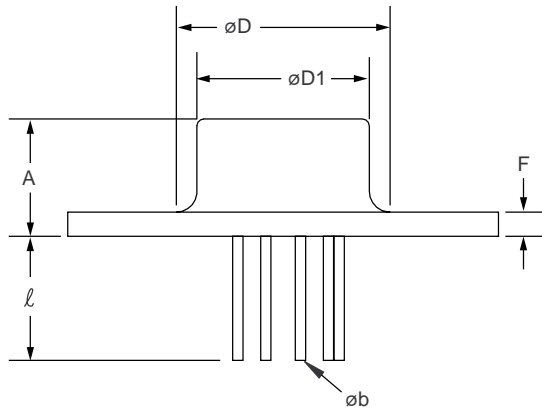

Symbol	Inches		Millimeters		Notes
	Min.	Max.	Min.	Max.	
A	.250	.340	6.35	8.64	
$\varnothing b$.028	.034	.71	.86	1
$\varnothing D$	—	.620	—	15.75	
$\varnothing D1$.470	.500	11.94	12.70	
e	.190	.210	4.83	5.33	
e1	.093	.107	2.36	2.72	
F	.050	.075	1.27	1.91	
ℓ	.360	—	9.14	—	
$\varnothing p$.142	.152	3.61	3.86	
q	.958	.962	24.33	24.43	
r1	—	.350	—	8.89	
r2	—	.145	—	3.68	
S	.570	.590	14.48	14.99	

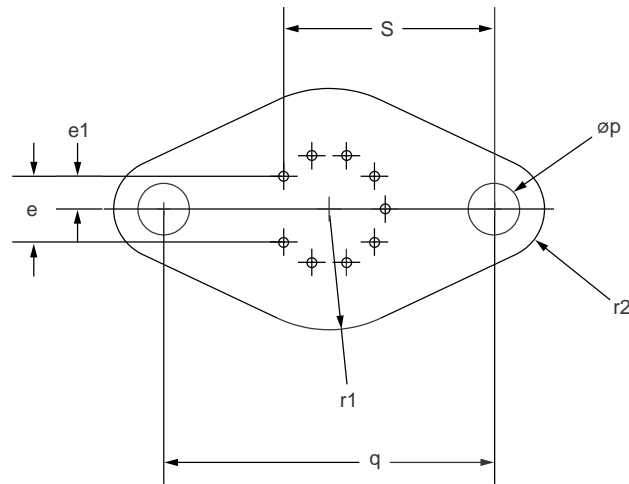

Notes:

1. All leads—increase maximum limit by .003 (.08mm) when lead finish is applied.

Mechanical Dimensions (continued)

14-Lead Ceramic DIP Package

Symbol	Inches		Millimeters		Notes
	Min.	Max.	Min.	Max.	
A	—	.200	—	5.08	
b1	.014	.023	.36	.58	8
b2	.045	.065	1.14	1.65	2
c1	.008	.015	.20	.38	8
D	—	.785	—	19.94	4
E	.220	.310	5.59	7.87	4
e	.100 BSC		2.54 BSC		5, 9
eA	.300 BSC		7.62 BSC		7
L	.125	.200	3.18	5.08	
Q	.015	.060	.38	1.52	3
s1	.005	—	.13	—	6
α	90°	105°	90°	105°	

Notes:

1. Index area: a notch or a pin one identification mark shall be located adjacent to pin one. The manufacturer's identification shall not be used as pin one identification mark.
2. The minimum limit for dimension "b2" may be .023 (.58mm) for leads number 1, 7, 8 and 14 only.
3. Dimension "Q" shall be measured from the seating plane to the base plane.
4. This dimension allows for off-center lid, meniscus and glass overrun.
5. The basic pin spacing is .100 (2.54mm) between centerlines. Each pin centerline shall be located within $\pm .010$ (.25mm) of its exact longitudinal position relative to pins 1 and 14.
6. Applies to all four corners (leads number 1, 7, 8, and 14).
7. "eA" shall be measured at the center of the lead bends or at the centerline of the leads when " α " is 90°.
8. All leads – Increase maximum limit by .003 (.08mm) measured at the center of the flat, when lead finish applied.
9. Twelve spaces.

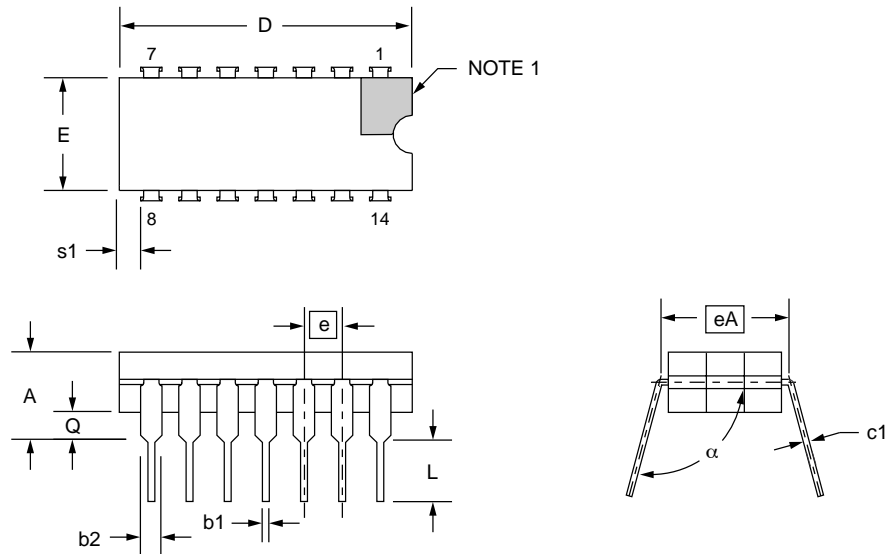

Mechanical Dimensions (continued)

14-Lead Plastic DIP Package

Symbol	Inches		Millimeters		Notes
	Min.	Max.	Min.	Max.	
A	—	.210	—	5.33	
A1	.015	—	.38	—	
A2	.115	.195	2.93	4.95	
B	.014	.022	.36	.56	
B1	.045	.070	1.14	1.78	
C	.008	.015	.20	.38	4
D	.725	.795	18.42	20.19	2
D1	.005	—	.13	—	
E	.300	.325	7.62	8.26	
E1	.240	.280	6.10	7.11	2
e	.100 BSC		2.54 BSC		
eB	—	.430	—	10.92	
L	.115	.200	2.92	5.08	
N	14		14		5

Notes:

1. Dimensioning and tolerancing per ANSI Y14.5M-1982.
2. "D" and "E1" do not include mold flashing. Mold flash or protrusions shall not exceed .010 inch (0.25mm).
3. Terminal numbers are shown for reference only.
4. "C" dimension does not include solder finish thickness.
5. Symbol "N" is the maximum number of terminals.

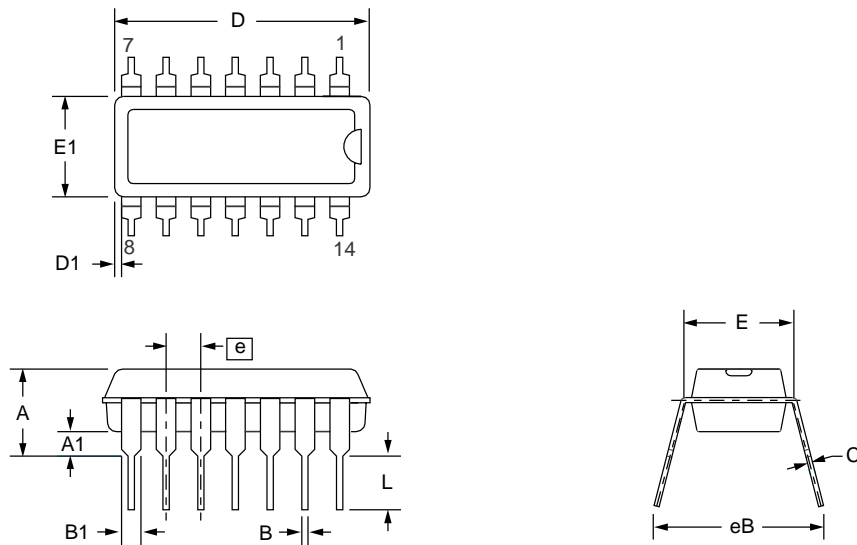

Ordering Information

Product Number	Temperature Range	Screening	Package	SMD Number
RC4194N	0° to +70°C	Commercial	14 pin Plastic DIP	
RC4194D	0° to +70°C	Commercial	14 pin Ceramic DIP	
RC4194K	0° to +70°C	Commercial	9 pin TO-66	
RM4194D	-55°C to +125°C	Commercial	14 pin Ceramic DIP	
RM4194D/883B	-55°C to +125°C	Military	14 pin Ceramic DIP	7705401CA
RM4194K	-55°C to +125°C	Commercial	9 pin TO-66	

Note:

1. /883B suffix denotes MIL-STD-883, Par. 1.2.1 compliant device.

LIFE SUPPORT POLICY

FAIRCHILD'S PRODUCTS ARE NOT AUTHORIZED FOR USE AS CRITICAL COMPONENTS IN LIFE SUPPORT DEVICES OR SYSTEMS WITHOUT THE EXPRESS WRITTEN APPROVAL OF THE PRESIDENT OF FAIRCHILD SEMICONDUCTOR CORPORATION. As used herein:

1. Life support devices or systems are devices or systems which, (a) are intended for surgical implant into the body, or (b) support or sustain life, and (c) whose failure to perform when properly used in accordance with instructions for use provided in the labeling, can be reasonably expected to result in a significant injury of the user.
2. A critical component in any component of a life support device or system whose failure to perform can be reasonably expected to cause the failure of the life support device or system, or to affect its safety or effectiveness.