

RP6 SERIES PLASTIC CONNECTORS

Scope

RP6 series are low cost and high performance plastic connectors which have been developed to meet the demand of miniaturization and light-weight of equipment. Its plug is right-angle wiring termination, type, which offers space-

saving in coupling height, and receptacle can be mounted by one touch pushing operation into a panel. This simple, easy to use connector is suitable for use on VTR camera and other handy electronic devices.

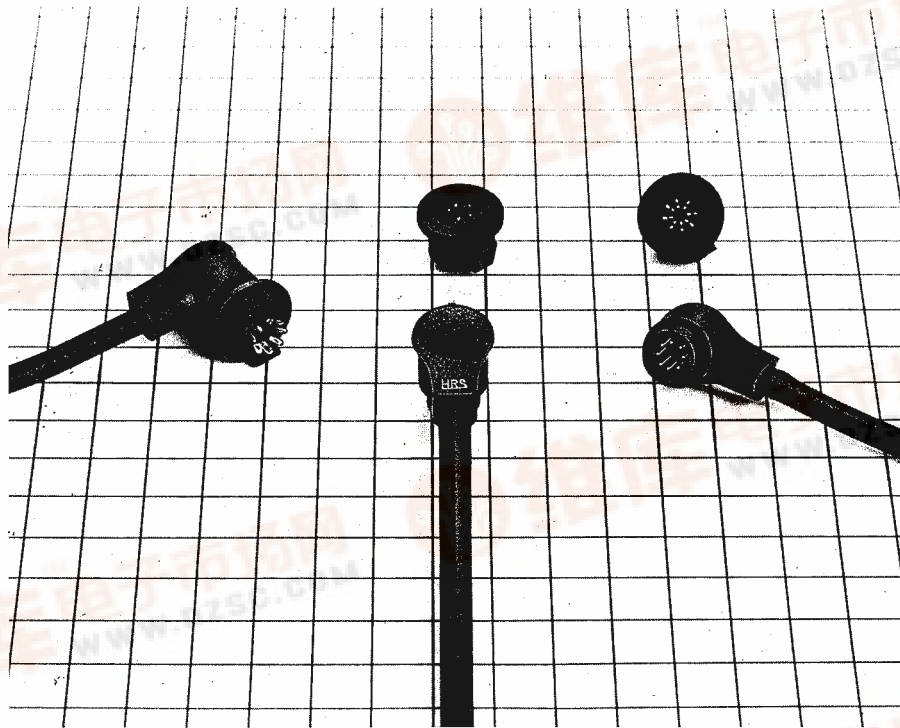

Features

- (1) Plug is L-style features low height plug coupling of 15 mm above panel.
- (2) RP6 series are of two types, 5 and 8-pin. And 8-pin type has a sophisticated receptacle, RP6-10RA-8S, which is designed to mount behind a decorative panel, so as to produce a lower height in coupling.
- (3) The mounting of the receptacle is a one-touch pushing operation into a panel without any screw.
- (4) Plug shell is designed for easy-to-use operation for insertion and extraction.
- (5) The cable length or cable end treatment follows customer's specifications.

Applications

Electronic View Finder of VTR Camera, Remote Control Device of VTR, Audio Equipment, and other portable

electronic equipment.



Specifications

Material and Finish

Description	Material	Finish
Molding	PVC (UL94V-0)	Black
Insulator	Polyamide resin (UL94V-1)	Black
Male pin	Copper alloy	Silver plating
Female pin	Phosphor bronze	Silver plating

Description	Test data
Contact resistance	15mΩ max. at DC1
Insulation resistance	200MΩ min. at DC100V
Withstanding voltage	AC150V for a minute
Rated voltage	AC30V, DC42V
Current rating	DC1A

Standard Cable Spec. (UL Style No. 2990)

No. of pin	5	8	10
Outer diameter	φ4.8	φ4.8	φ5.3
No. of conductor	5	8	9 (shielded)
Construction	12/φ0.12 (AWG#26)	12/φ0.12 (AWG#26)	12/φ0.12 (AWG#26)

Remark: Please specify cable length, terminal dimensions, termination, etc. when ordering.

Plug

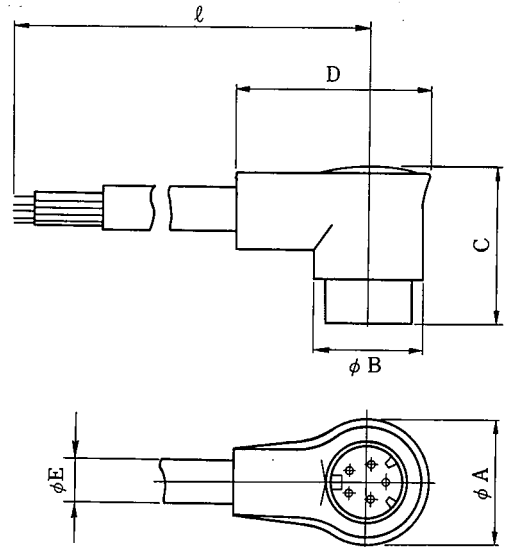
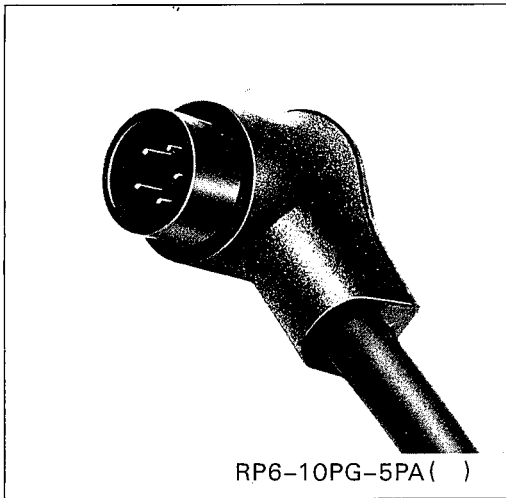

(An example in shape)

HRS No.	Part No.	No. of pins	φA	φB	C	D	φE	ℓ
113-0152-3	RP6-10PG-5PA(290)	5	14.6	12.4	18	22.3	4.8	290
113-0160-1	RP6-10PF-8P(1000)	8	14.6	12.4	18	22.3	4.8	1000
113-0117-2	RP6-12P-10PA(383)	10	17	15	21.6	26	5.3	383

Remark: Numbers shown with () is the cable length "ℓ" at millimeter.

Receptacle

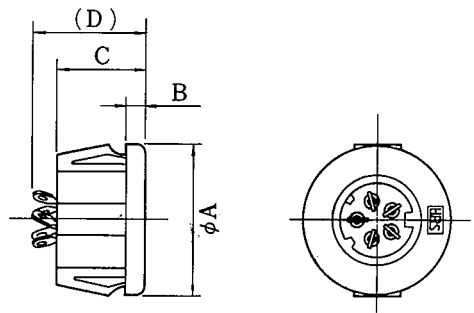
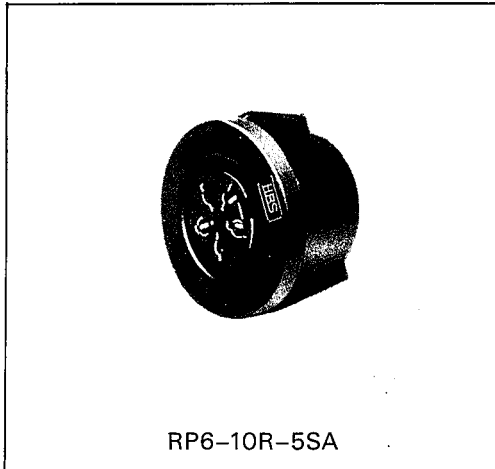

(An example in shape)

HRS No.	Part No.	No. of pins	ϕA	B	C	D	Weight	Remarks
113-0159-2	RP6-10R-5SA	5	16	2	9.5	12	About 2g	
113-0035-0	RP6-10R-8S	8	16	2	9.5	12	About 2g	
113-0035-0-03	RP6-10R-8S(03)	8	16	2	9.5	12	About 2g	Solder plating
113-0052-9	RP6-12R-10S	10	18	2	9.5	12	About 2g	

Remark: For mounting hole size, see page 121.

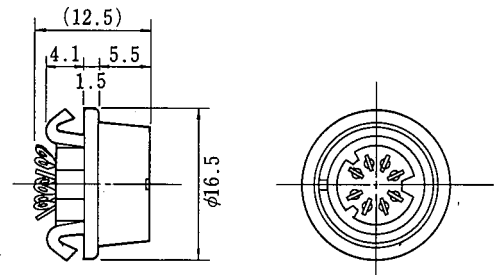
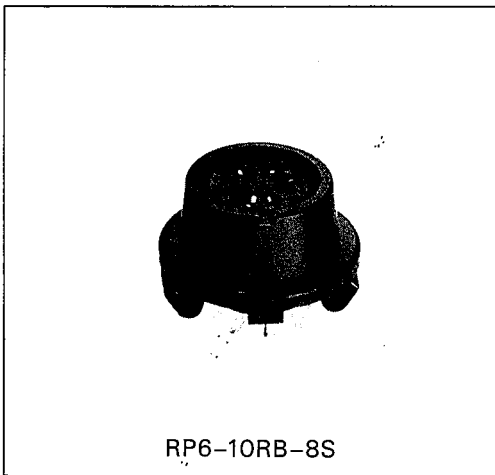

HRS No.	Part No.	No. of pins	Weight
113-0066-3	RP6-10RB-8S	8	About 2g

Remark: For mounting hole size, see page 121.

Receptacle (Crimp Type)

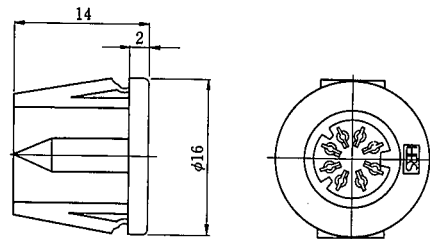
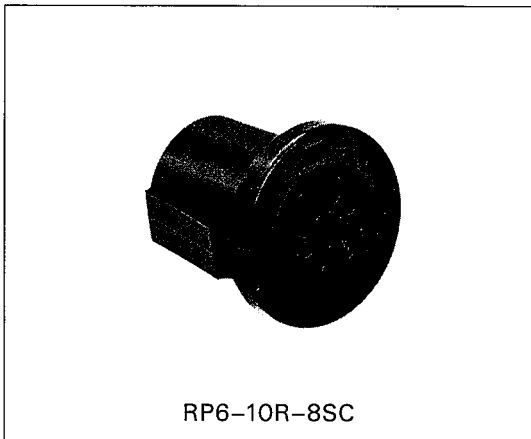

HRS No.	Part No.	No. of pins	Weight
113-0224-2	RP6-10R-8SC	8	About 2g

Remark: For mounting hole size, see page 121.

Receptacle (Dip Type)

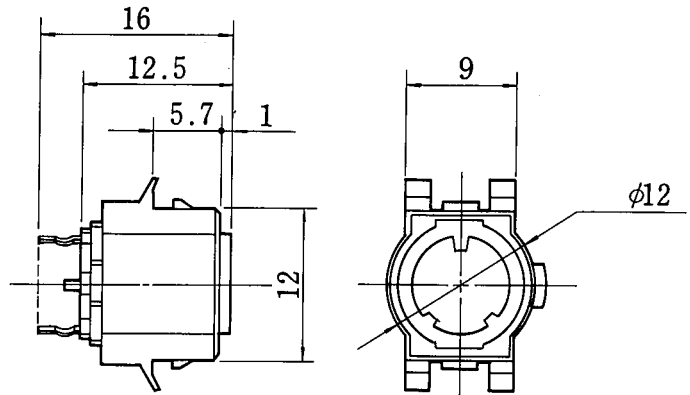
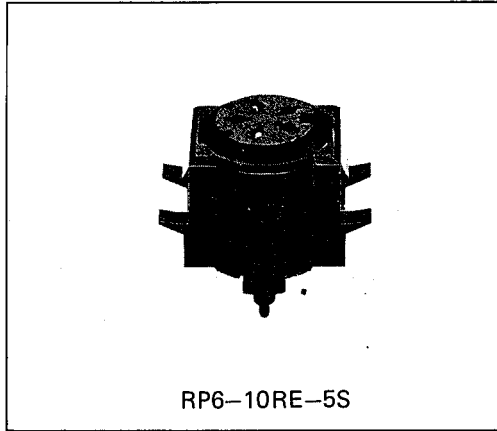

HRS No.	Part No.	No. of pins	Weight
113-0136-7	RP6-10RE-5S	5	About 2g
113-0137-0	RP6-10RE-8S	8	About 2g

Remark: For mounting hole size, see page 121.

(Dip post arrangement)

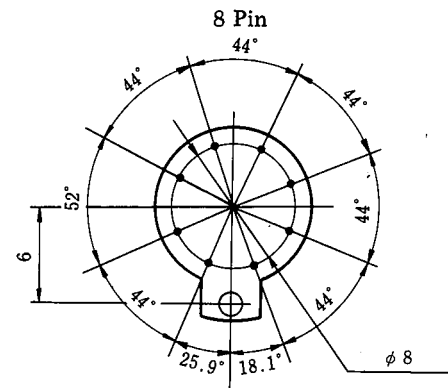
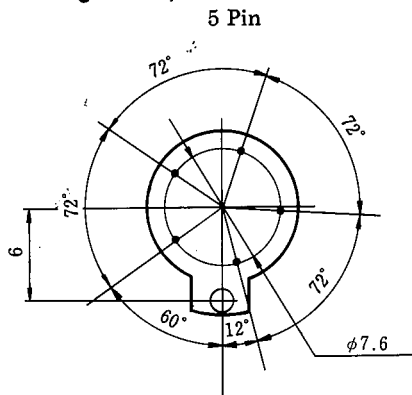

Remark: Dimensions one viewing from the back side of PCB. (Through hole $\phi 1$)

● Female Pin

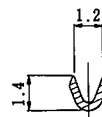
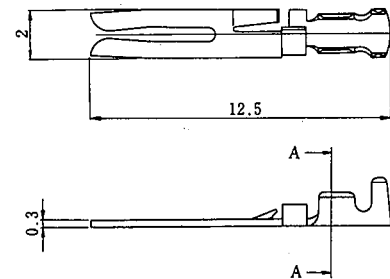
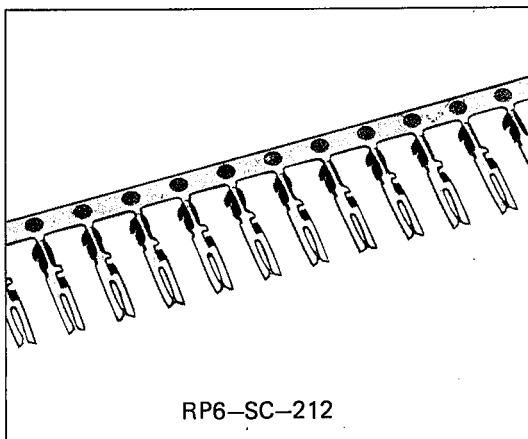

Section A-A

Type	HRS No.	Part No.	Applicable wire
Chain contact	113-0228-3	RP6-SC-212	AWG#26~#30

Remark: Bulk in bags of 100 pcs. Chain on reels of 10,000 pcs.

Applicable tools

Type	Item	HRS No.	Part No.	Applicable terminal	Applicable wire and Applicable Cable diameter
Automatic	Automatic crimping machine body	901-0005-4	CM-105	-	-
	Applicator	901-2011-8	AP105-RP6-SC-1	RP6-SC-212	AWG#26~#30
	Extractor	150-0039-0	RP6-SC-TP	-	-



Extraction Tool

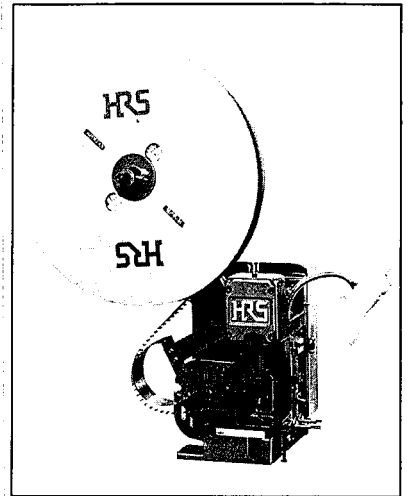

Auto Crimp Tool
CM-105

Panel Cutout

