



# 54LS47/DM74LS47 BCD to 7-Segment Decoder/Driver

## General Description

The 'LS47 accepts four lines of BCD (8421) input data, generates their complements internally and decodes the data with seven AND/OR gates having open-collector outputs to drive indicator segments directly. Each segment output is guaranteed to sink 24 mA in the ON (LOW) state and withstand 15V in the OFF (HIGH) state with a maximum leakage current of 250  $\mu$ A. Auxiliary inputs provided blanking, lamp test and cascadable zero-suppression functions. Also see the 'LS47 data sheet.

## Features

- Open-collector outputs
- Drive indicator segments directly
- Cascadable zero-suppression capability
- Lamp test input

## Connection Diagram

Dual-In-Line Package

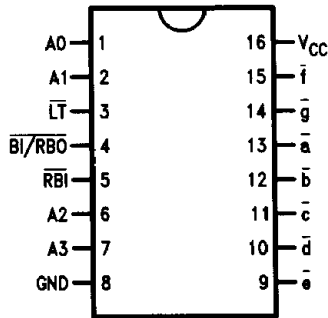

TL/F/9817-1

Order Number 54LS47DMQB, 54LS47FMBQB,  
DM74LS47M or DM74LS47N  
See NS Package Number J16A, M16A, N16E or W16A

Pin Names	Description
A0-A3	BCD Inputs
RBI	Ripple Blanking Input (Active LOW)
LT	Lamp Test Input (Active LOW)
BI/RBO	Blanking Input (Active LOW) or Ripple Blanking Output (Active LOW)
a-g	*Segment Outputs (Active LOW)

\*OC—Open Collector

## Absolute Maximum Ratings (Note)

If Military/Aerospace specified devices are required, please contact the National Semiconductor Sales Office/Distributors for availability and specifications.

Supply Voltage	7V
Input Voltage	7V
Operating Free Air Temperature Range	
54LS	-55°C to +125°C
DM74LS	0°C to +70°C
Storage Temperature Range	-65°C to +150°C

Note: The "Absolute Maximum Ratings" are those values beyond which the safety of the device cannot be guaranteed. The device should not be operated at these limits. The parametric values defined in the "Electrical Characteristics" table are not guaranteed at the absolute maximum ratings. The "Recommended Operating Conditions" table will define the conditions for actual device operation.

## Recommended Operating Conditions

Symbol	Parameter	54LS47			DM74SL47			Units
		Min	Nom	Max	Min	Nom	Max	
V <sub>CC</sub>	Supply Voltage	4.5	5	5.5	4.75	5	5.25	V
V <sub>IH</sub>	High Level Input Voltage	2			2			V
V <sub>IL</sub>	Low Level Input Voltage			0.7			0.8	V
I <sub>OH</sub>	High Level Output Current @ 15V = V <sub>OH</sub> *			-50			-250	μA
I <sub>OL</sub>	Low Level Output Current			12			24	mA
T <sub>A</sub>	Free Air Operating Temperature	-55		125	0		70	°C

\*OFF state at  $\bar{a}-\bar{g}$ .

## Electrical Characteristics

Over recommended operating free air temperature range (unless otherwise noted)

Symbol	Parameter	Conditions	Min	Typ (Note 1)	Max	Units
V <sub>I</sub>	Input Clamp Voltage	V <sub>CC</sub> = Min, I <sub>I</sub> = -18 mA			-1.5	V
V <sub>OH</sub>	High Level Output Voltage	V <sub>CC</sub> = Min, I <sub>OH</sub> = Max, V <sub>IL</sub> = Max	54LS	2.4		V
			DM74	2.7	3.4	
V <sub>OL</sub>	Low Level Output Voltage	V <sub>CC</sub> = Min, I <sub>OL</sub> = Max, V <sub>IH</sub> = Min	54LS		0.4	V
			DM74		0.35	
		I <sub>OL</sub> = 4 mA, V <sub>CC</sub> = Min	DM74		0.25	
I <sub>I</sub>	Input Current @ Max Input Voltage	V <sub>CC</sub> = Max, V <sub>I</sub> = 10V			100	μA
I <sub>IH</sub>	High Level Input Current	V <sub>CC</sub> = Max, V <sub>I</sub> = 2.7V			20	μA
I <sub>IL</sub>	Low Level Input Current	V <sub>CC</sub> = Max, V <sub>I</sub> = 0.4V			-0.4	mA
I <sub>OS</sub>	Short Circuit Output Current	V <sub>CC</sub> = Max (Note 2), I <sub>OS</sub> at $\overline{BI}/\overline{RBO}$	54LS	-0.3	-2.0	mA
			DM74	-0.3	-2.0	
I <sub>CC</sub>	Supply Current	V <sub>CC</sub> = Max			13	mA

Note 1: All typicals are at V<sub>CC</sub> = 5V, T<sub>A</sub> = 25°C.

Note 2: Not more than one output should be shorted at a time, and the duration should not exceed one second.

## Switching Characteristics at $V_{CC} = +5.0V$ , $T_A = +25^\circ C$

Symbol	Parameter	Conditions	$R_L = 665\Omega$		Units
			$C_L = 15\text{ pF}$		
			Min	Max	
$t_{PLH}$ $t_{PHL}$	Propagation Delay An to $\bar{a}-\bar{g}$			100 100	ns
$t_{PLH}$ $t_{PHL}$	Propagation Delay $\bar{RBI}$ to $\bar{a}-\bar{g}$ *			100 100	ns

\* $\bar{LT} = \text{HIGH}$ , A0-A3 = LOW

### Functional Description

The 'LS47 decodes the input data in the pattern indicated in the Truth Table and the segment identification illustration. If the input data is decimal zero, a LOW signal applied to the  $\bar{RBI}$  blanks the display and causes a multidigit display. For example, by grounding the  $\bar{RBI}$  of the highest order decoder and connecting its  $\bar{BI}/\bar{RBO}$  to  $\bar{RBI}$  of the next lowest order decoder, etc., leading zeros will be suppressed. Similarly, by grounding  $\bar{RBI}$  of the lowest order decoder and connecting its  $\bar{BI}/\bar{RBO}$  to  $\bar{RBI}$  of the next highest order decoder, etc., trailing zeros will be suppressed. Leading and trailing zeros can be suppressed simultaneously by using external gates, i.e.: by driving  $\bar{RBI}$  of an intermediate decoder from an OR

gate whose inputs are  $\bar{BI}/\bar{RBO}$  of the next highest and lowest order decoders.  $\bar{BI}/\bar{RBO}$  also serves as an unconditional blanking input. The internal NAND gate that generates the  $\bar{RBO}$  signal has a resistive pull-up, as opposed to a totem pole, and thus  $\bar{BI}/\bar{RBO}$  can be forced LOW by external means, using wired-collector logic. A LOW signal thus applied to  $\bar{BI}/\bar{RBO}$  turns off all segment outputs. This blanking feature can be used to control display intensity by varying the duty cycle of the blanking signal. A LOW signal applied to  $\bar{LT}$  turns on all segment outputs, provided that  $\bar{BI}/\bar{RBO}$  is not forced LOW.

# Logic Diagram

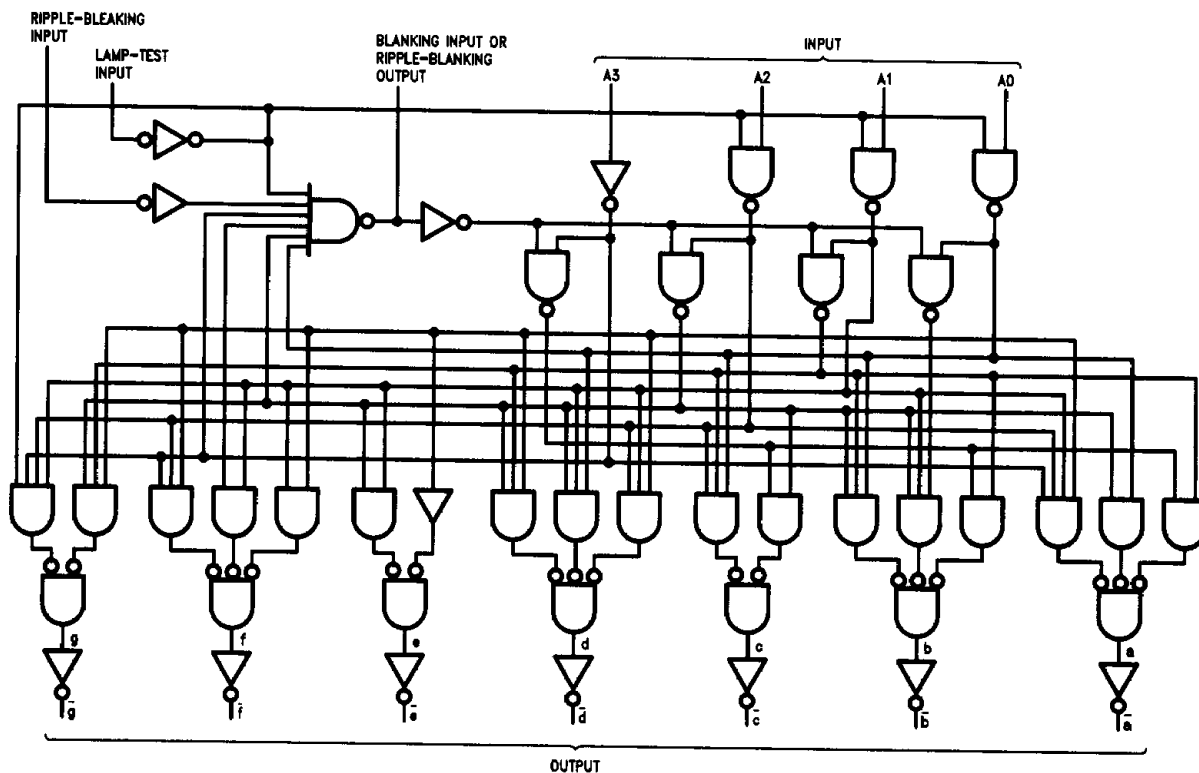

TL/F/9817-3

## Numerical Designations—Resultant Displays

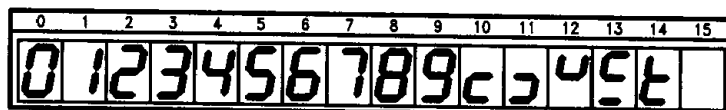

TL/F/9817-4

# Logic Symbol

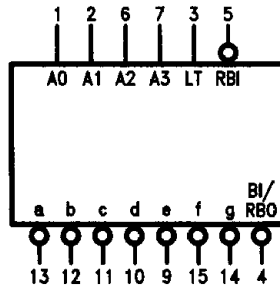

TL/F/9817-2

V<sub>CC</sub> = Pin 16  
GND = Pin 8

## Truth Table

Decimal or Function	Inputs							Outputs							Note
	LT	RBI	A3	A2	A1	A0	BI/RBO	a	b	c	d	e	f	g	
0	H	H	L	L	L	L	H	L	L	L	L	L	L	H	1
1	H	X	L	L	L	H	H	H	L	L	L	H	H	H	1
2	H	X	L	L	H	L	H	L	L	H	L	L	H	L	
3	H	X	L	L	H	H	H	L	L	L	L	H	H	L	
4	H	X	L	H	L	L	H	H	L	L	H	H	L	L	
5	H	X	L	H	L	H	H	L	H	L	L	H	L	L	
6	H	X	L	H	H	L	H	H	H	L	L	L	L	L	
7	H	X	L	H	H	H	H	L	L	L	H	H	H	H	
8	H	X	H	L	L	L	H	L	L	L	L	L	L	L	
9	H	X	H	L	L	H	H	L	L	L	H	H	L	L	
10	H	X	H	L	H	L	H	H	H	H	L	L	H	L	
11	H	X	H	L	H	H	H	H	H	L	L	H	H	L	
12	H	X	H	H	L	L	H	H	L	H	H	H	L	L	
13	H	X	H	H	L	H	H	L	H	H	L	H	L	L	
14	H	X	H	H	H	L	H	H	H	H	L	L	L	L	
15	H	X	H	H	H	H	H	H	H	H	H	H	H	H	
BI	X	X	X	X	X	X	L	H	H	H	H	H	H	H	2
RBI	H	L	L	L	L	L	L	H	H	H	H	H	H	H	3
LT	L	X	X	X	X	X	H	L	L	L	L	L	L	L	4

**Note 1:** BI/RBO is wire-AND logic serving as blanking input (BI) and/or ripple-blanking output (RBO). The blanking out (BI) must be open or held at a HIGH level when output functions 0 through 15 are desired, and ripple-blanking input (RBI) must be open or at a HIGH level if blanking or a decimal 0 is not desired. X = input may be HIGH or LOW.

**Note 2:** When a LOW level is applied to the blanking input (forced condition) all segment outputs go to a HIGH level regardless of the state of any other input condition.

**Note 3:** When ripple-blanking input (RBI) and inputs A0, A1, A2 and A3 are LOW level, with the lamp test input at HIGH level, all segment outputs go to a HIGH level and the ripple-blanking output (RBO) goes to a LOW level (response condition).

**Note 4:** When the blanking input/ripple-blanking output (BI/RBO) is open or held at a HIGH level, and a LOW level is applied to lamp test input, all segment outputs go to a LOW level.

Copyright © Each Manufacturing Company.

All Datasheets cannot be modified without permission.

This datasheet has been download from :

[www.AllDataSheet.com](http://www.AllDataSheet.com)

100% Free DataSheet Search Site.

Free Download.

No Register.

Fast Search System.

[www.AllDataSheet.com](http://www.AllDataSheet.com)