

60 Amp Schottky Rectifier

SBR6035PF — SBR6045PF

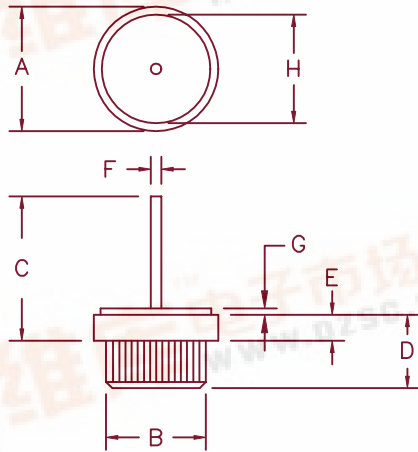

Dim.	Inches		Millimeter		Notes
	Minimum	Maximum	Minimum	Maximum	
A	.590	.630	15.0	16.0	Dia.
B	.499	.510	12.6	13.0	Dia.
C	—	.600	—	15.2	
D	.350	.370	8.90	9.40	
E	.090	.130	2.28	3.30	
F	.097	.103	2.46	2.62	Dia.
G	.030	.035	.762	.900	
H	.500	.510	12.7	13.0	Dia.

Microsemi Catalog Number	Working Peak Reverse Voltage	Repetitive Peak Reverse Voltage
SBR6035PF*	35V	35V
SBR6040PF*	40V	40V
SBR6045PF*	45V	45V

*Add the Suffix R for Reverse Polarity

- Schottky Barrier Rectifier
- Guard Ring Protected
- 150°C Junction Temperature
- VRRM – 35 to 45 Volts
- Reverse Energy Tested

Electrical Characteristics

Average forward current	I _{F(AV)} 60 Amps	T _C = 89°C, Square wave, R _{θJC} = 1.0°C/W
Maximum surge current	I _{FSM} 800 Amps	8.3 ms, half sine, T _J = 150°C
Max repetitive peak reverse current	I _{R(OV)} 2 Amps	f = 1 KHz, 25°C, 1 μsec Square wave
Max peak forward voltage	V _{FM} .58 Volts	I _{FM} = 60A: T _J = 150°C*
Max peak forward voltage	V _{FM} .60 Volts	I _{FM} = 60A: T _J = 25°C*
Max peak reverse current	I _{RM} 600 mA	V _R = 5.0V, T _J = 25°C
Max peak reverse current	I _{RM} 2 mA	V _{RRM} , T _J = 125°C*
Maximum junction capacitance	C _J 2700 pF	V _{RRM} , T _J = 25°C

*Pulse test: Pulse width 300 μsec, Duty cycle 2%

Thermal and Mechanical Characteristics

Storage temp range	T _{STG}	-55°C to 175°C
Operating junction temp range	T _J	-55°C to 150°C
Max thermal resistance	R _{θJC}	1.0°C/W Junction to case
Weight		.32 ounces (9.2 grams) typical

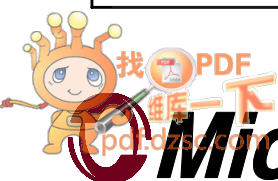

SBR6035PF — SBR6045PF

Figure 1
Typical Forward Characteristics

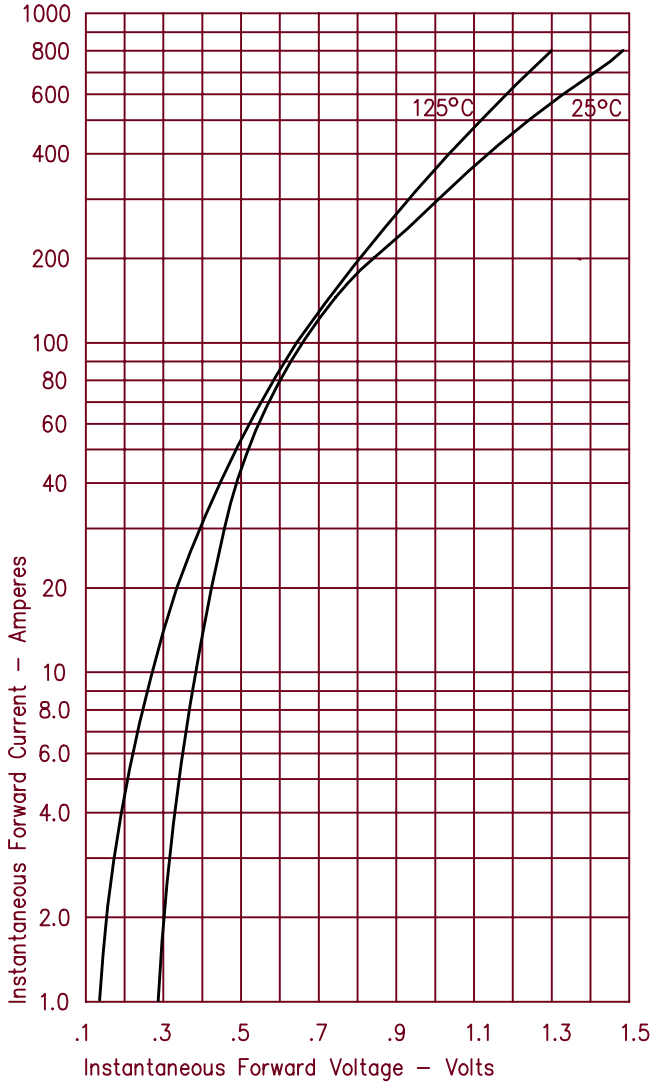

Figure 3
Typical Junction Capacitance

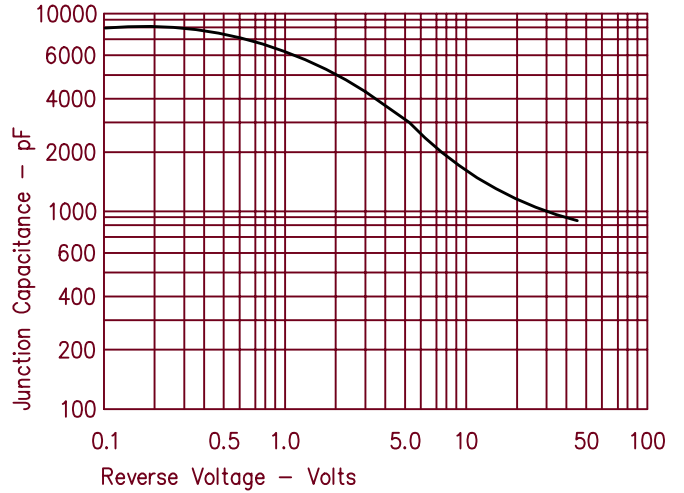

Figure 4
Forward Current Derating

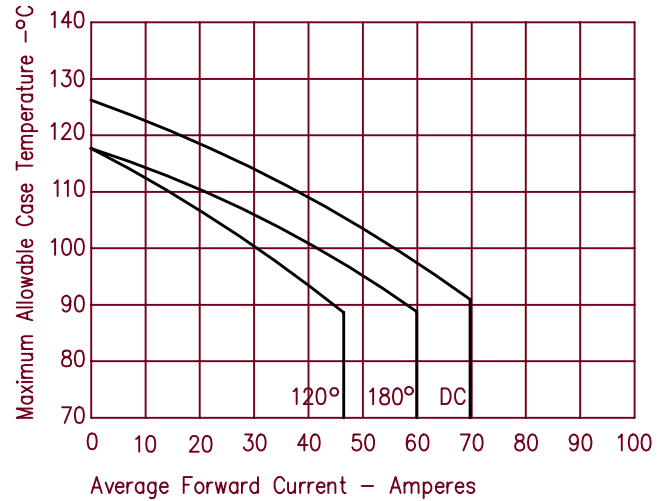

Figure 2
Typical Reverse Characteristics

