



Si6968BEDQ
Vishay Siliconix

Dual N-Channel 2.5-V (G-S) MOSFET
Common Drain, ESD Protection

PRODUCT SUMMARY		
V _{DS} (V)	r _{DS(on)} (Ω)	I _D (A)
20	0.022 @ V _{GS} = 4.5 V	6.5
	0.030 @ V _{GS} = 2.5 V	5.5

FEATURES

- TrenchFET® Power MOSFET
- ESD Protected: 3000 V

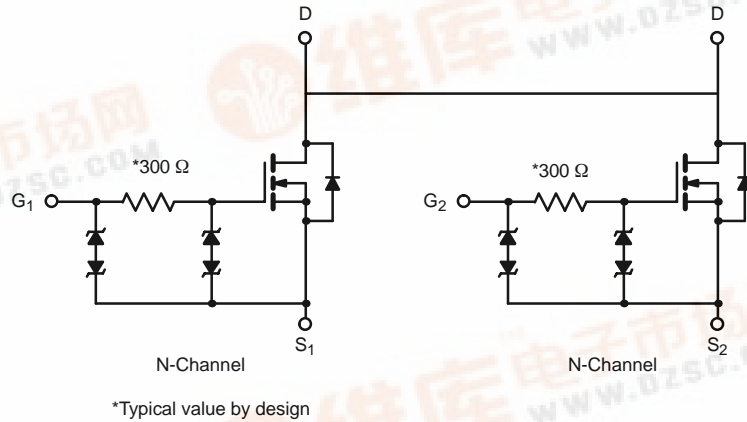
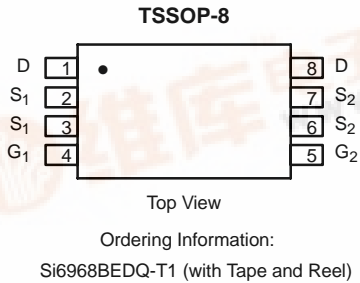

ABSOLUTE MAXIMUM RATINGS (T _A = 25°C UNLESS OTHERWISE NOTED)					
Parameter	Symbol	10 secs	Steady State	Unit	
Drain-Source Voltage	V _{DS}	20		V	
Gate-Source Voltage	V _{GS}	± 12			
Continuous Drain Current (T _J = 150°C) ^a	I _D	T _A = 25°C	6.5	5.2	A
		T _A = 70°C	5.5	3.5	
Pulsed Drain Current	I _{DM}	30			
Continuous Source Current (Diode Conduction) ^a	I _S	1.5	1.0	W	
Maximum Power Dissipation ^a	P _D	T _A = 25°C	1.5		1.0
		T _A = 70°C	0.96		0.64
Operating Junction and Storage Temperature Range	T _J , T _{stg}	-55 to 150		°C	

THERMAL RESISTANCE RATINGS					
Parameter	Symbol	Typ	Max	Unit	
Maximum Junction-to-Ambient ^a	R _{thJA}	t ≤ 10 sec	72	83	°C/W
		Steady-State	100	120	
Maximum Junction-to-Foot (Drain)	R _{thJF}	55	70		

Notes:
a. Surface Mounted on FR4 Board, t ≤ 10 sec.



SPECIFICATIONS (T_J = 25 °C UNLESS OTHERWISE NOTED)

Parameter	Symbol	Test Condition	Min	Typ ^a	Max	Unit
Static						
Gate Threshold Voltage	V _{GS(th)}	V _{DS} = V _{GS} , I _D = 250 μA	0.6		1.6	V
Gate-Body Leakage	I _{GSS}	V _{DS} = 0 V, V _{GS} = ±4.5 V			±200	nA
Zero Gate Voltage Drain Current	I _{DSS}	V _{DS} = 16 V, V _{GS} = 0 V			1	μA
		V _{DS} = 16 V, V _{GS} = 0 V, T _J = 70 °C			25	
On-State Drain Current ^b	I _{D(on)}	V _{DS} ≤ 5 V, V _{GS} = 4.5 V	30			A
Drain-Source On-State Resistance ^b	r _{DS(on)}	V _{GS} = 4.5 V, I _D = 6.5 A		0.0165	0.022	Ω
		V _{GS} = 2.5 V, I _D = 5.5 A		0.023	0.030	
Forward Transconductance ^b	g _{fs}	V _{DS} = 10 V, I _D = 6.5 A		30		S
Diode Forward Voltage ^b	V _{SD}	I _S = 1.5 A, V _{GS} = 0 V		0.71	1.2	V
Dynamic^a						
Total Gate Charge	Q _g	V _{DS} = 10 V, V _{GS} = 4.5 V, I _D = 6.5 A		12	18	nC
Gate-Source Charge	Q _{gs}			2.2		
Gate-Drain Charge	Q _{gd}			3.6		
Turn-On Delay Time	t _{d(on)}	V _{DD} = 10 V, R _L = 10 Ω I _D ≅ 1 A, V _{GEN} = 4.5 V, R _G = 6 Ω		245	365	ns
Rise Time	t _r			330	495	
Turn-Off Delay Time	t _{d(off)}			860	1300	
Fall Time	t _f			510	765	

Notes

- a. For design aid only; not subject to production testing.
- b. Pulse test; pulse width ≤ 300 μs, duty cycle ≤ 2%.

TYPICAL CHARACTERISTICS (25 °C UNLESS NOTED)

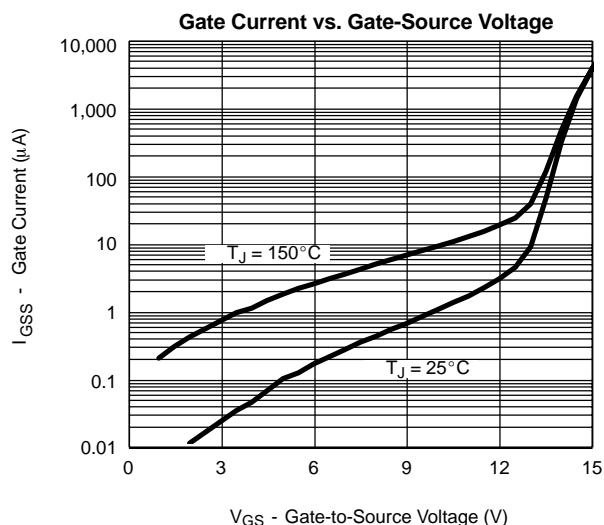
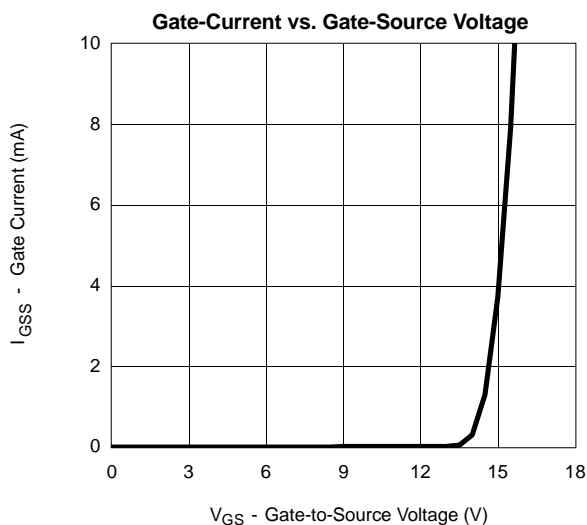



TYPICAL CHARACTERISTICS (25°C UNLESS NOTED)

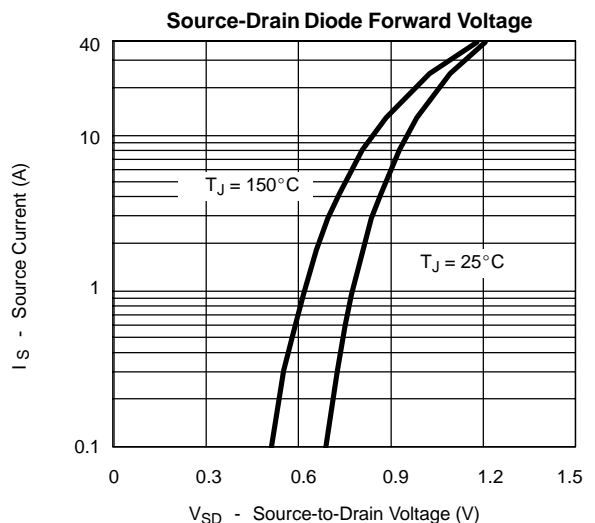
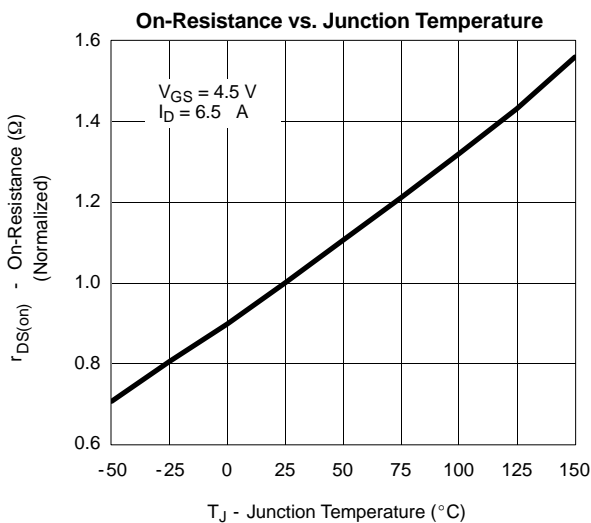
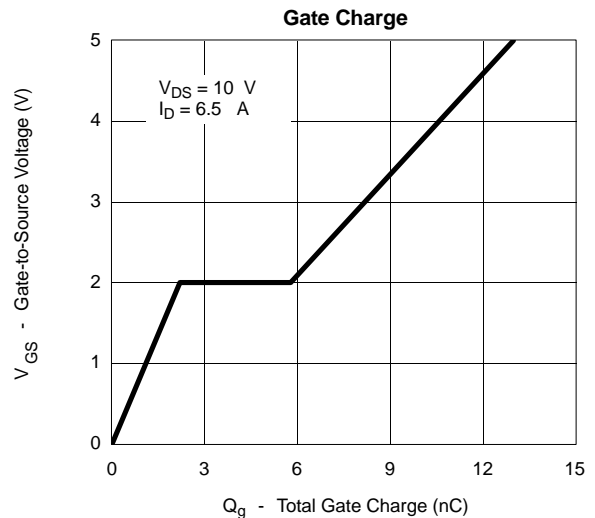
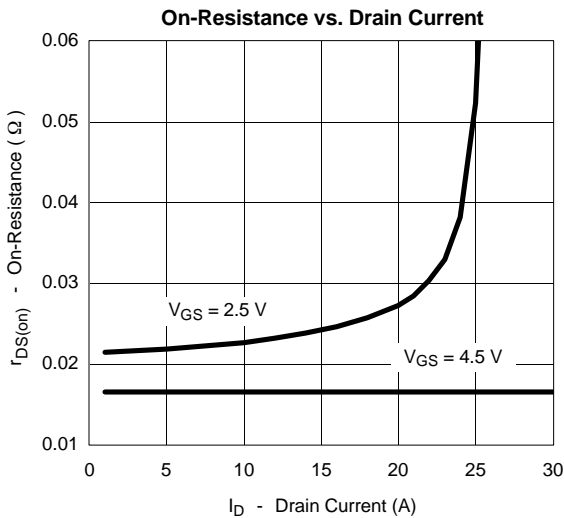
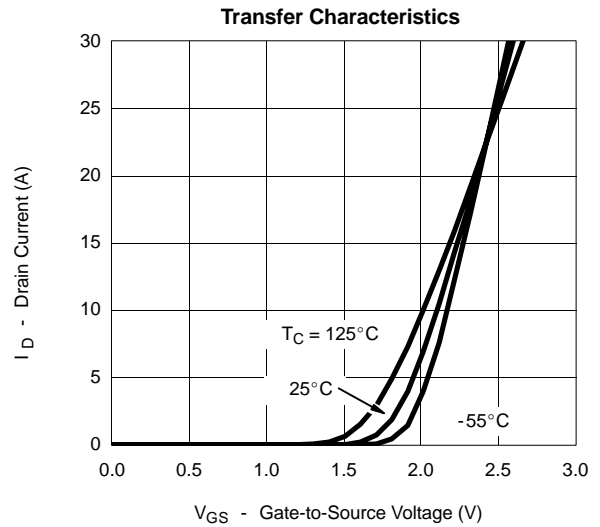
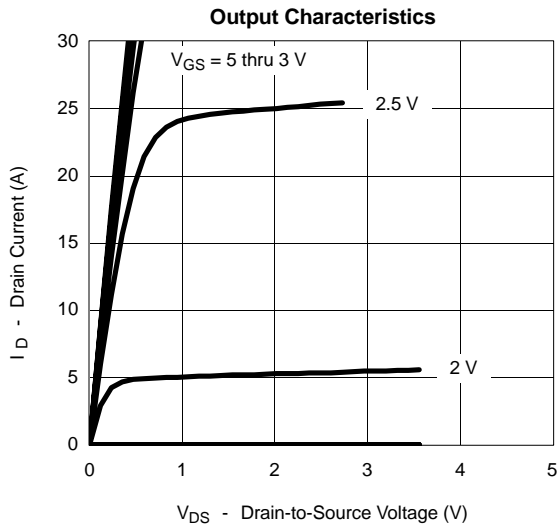



TYPICAL CHARACTERISTICS (25°C UNLESS NOTED)

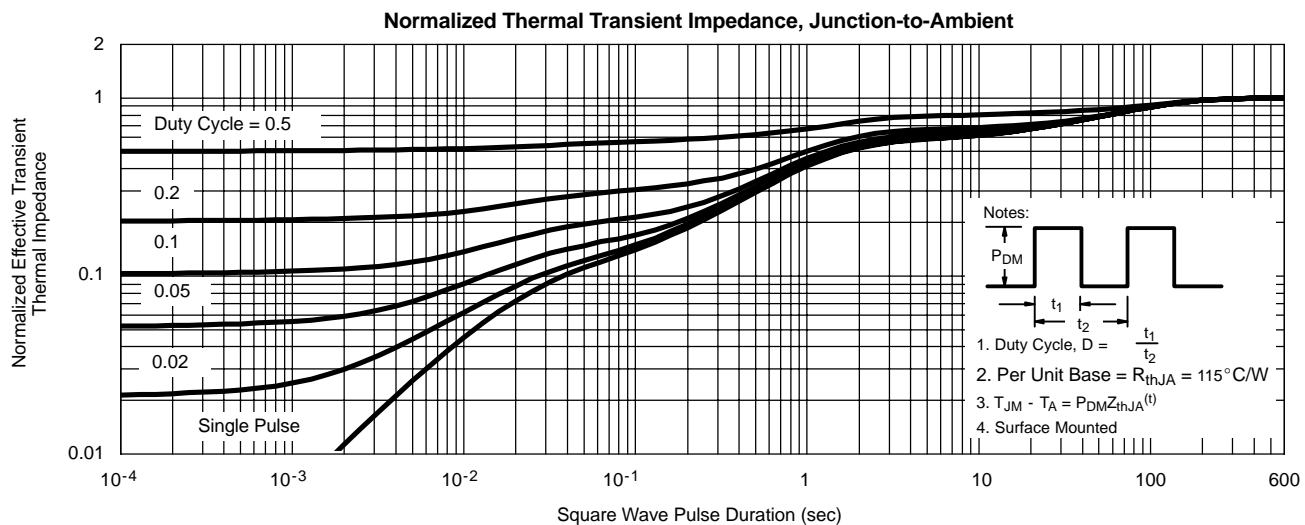
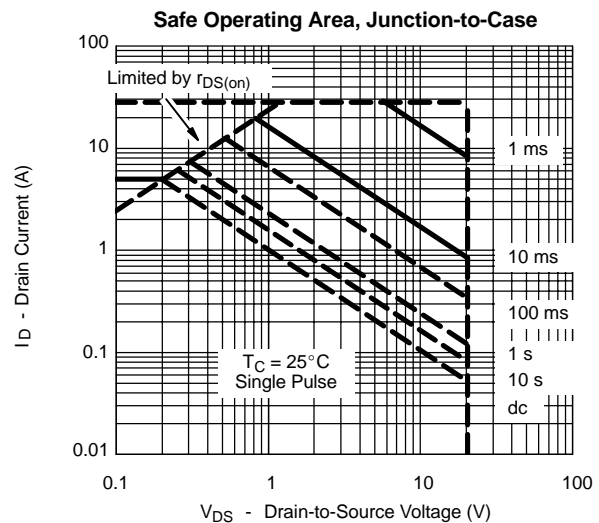
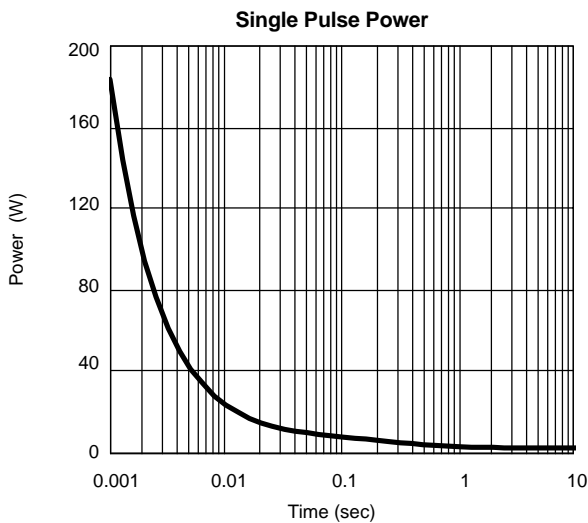
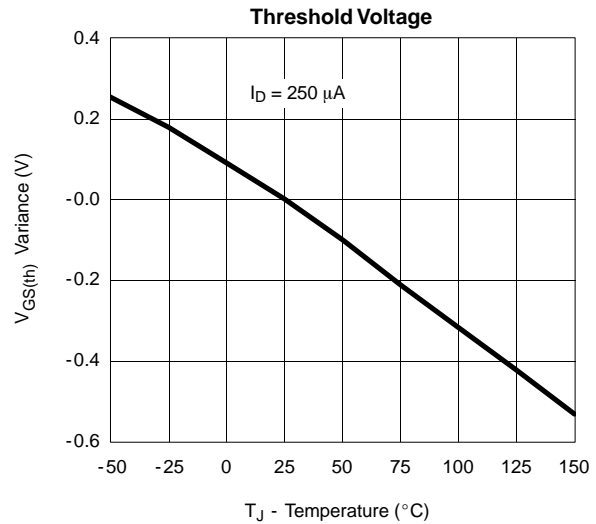
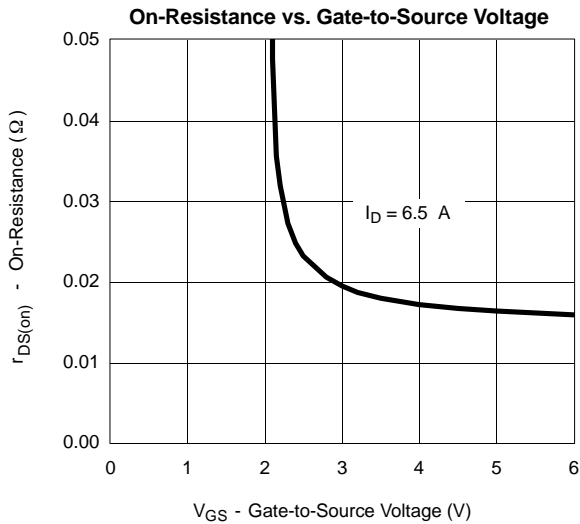



TYPICAL CHARACTERISTICS (25°C UNLESS NOTED)

