



New Product

SiP43101
Vishay Siliconix

Dual Output Power Switch with Inverting Input

FEATURES

- Two Output Power Switches
- Total Output Drive — 200 mA Continuous
- 9-V to 35-V Supply Voltage Range
- Low Side or High Side Switch Configuration
- User Programmable Phasing of Output Switches
- Internal Output Over Voltage Clamp For Driving Inductive Loads

- Current Limit Protection
- Thermal Shutdown Protection
- UVLO With User Programmable Time Delay

APPLICATIONS

- Optical Detectors for Factory Automation

DESCRIPTION

SiP43101 is a dual power switch IC which contains all control and power switching circuitry required to drive resistive and inductive loads in industrial applications. The output switches are NPN power transistors which can be configured as either high-side or low-side switches. These switches can operate from voltages as high as 35 V and have a continuous output current rating of 200 mA, combined or individually. Internal zener diodes are provided to clamp the power switch voltages to safe levels when driving inductive loads. The IN1 pin is a non-inverting input which controls the output of switch 1. A 2-input Exclusive OR gate input controls switch 2, allowing

switch 2 to be controlled by either an inverting or non-inverting control signal. SiP43101 contains under voltage lockout, UVLO, a user definable turn on delay, current limit, short circuit protection, and thermal shutdown.

SiP43101 is available in 16-pin TSSOP and PowerPAK® MLP-44 packages for operation over the temperature range of -40 to 85 °C.

TYPICAL APPLICATION CIRCUIT

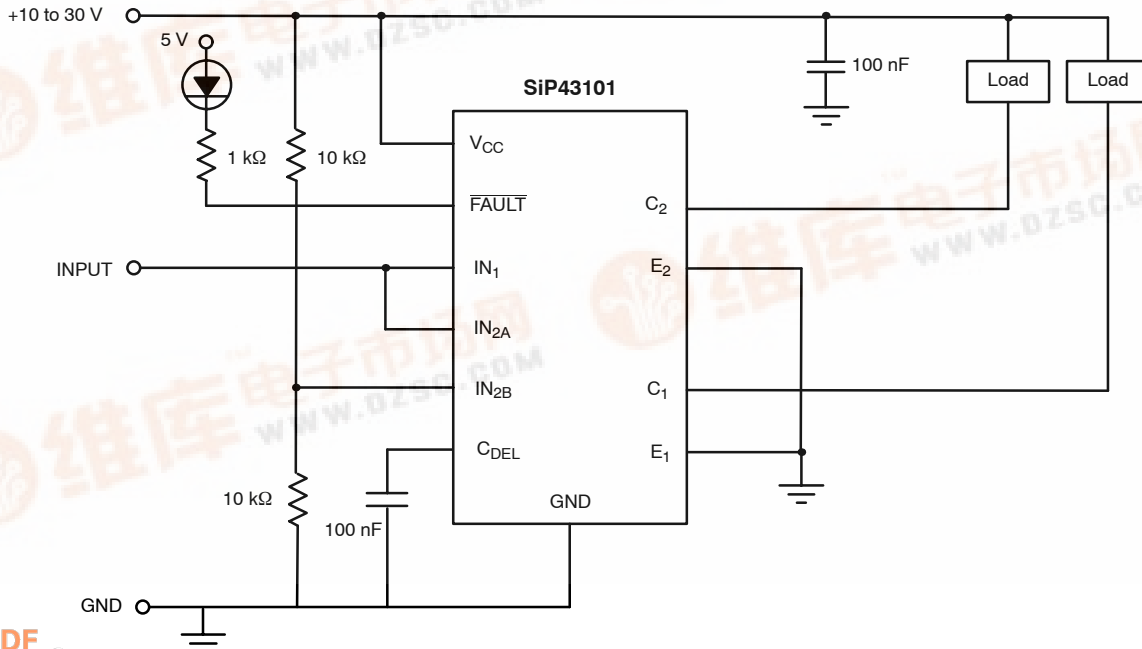

Both Switches Configured as Low-Side, Switch 2 Inverted With Respect to Switch 1



SiP43101

Vishay Siliconix

New Product



ABSOLUTE MAXIMUM RATINGS

V _{CC}	35 V	$\overline{\text{FAULT}}$ Output Current	10 mA
C1, E1, C2, E2	35 V	$\overline{\text{FAULT}}$ Output Voltage	17.5 V
C1-E1, C2-E2 (clamped by internal circuitry)	52 V	IN ₁ , IN _{2A} , IN _{2B}	17.5 V
Output Current		Storage Temperature	-65 to 150°C
Continuous for one Output	200 mA	Junction Temperature	-55 to 125°C
Peak for one Output	1.3 A		

Currents are positive into, negative out of the specified terminal.

Stresses beyond those listed under "Absolute Maximum Ratings" may cause permanent damage to the device. These are stress ratings only, and functional operation of the device at these or any other conditions beyond those indicated in the operational sections of the specifications is not implied. Exposure to absolute maximum rating conditions for extended periods may affect device reliability.

RECOMMENDED OPERATING RANGE

V _{CC}	9 to 32 V	Operating Temperature Range	-40 to 85°C
-----------------------	-----------	-----------------------------------	-------------

SPECIFICATIONS						
Parameter	Symbol	Test Conditions Unless Specified V _{CC} = 25 V, IN ₁ , IN ₂ = 0 V, IN ₁ , IN ₂ , INV2 = 5 V C _{DEL} = 10 nF, T _A = T _J	Limits			Unit
			Min ^a	Typ ^b	Max ^a	
Power Supply						
Supply Voltage	V _{CC}		9		35	V
Supply Current	I _{CC}	-40 to 85°C, Both Inputs Enabled		6	9	mA
Logic Inputs (IN₁, IN_{2A}, IN_{2B})						
Digital Input High Level	V _{IH}		3.5		9	V
Digital Input Low Level	V _{IL}				1.5	
Input Bias Current, Low Level	I _{IL}	IN ₁ , IN _{2A} , IN _{2B} = 0 V		-0.40		μA
Input Bias Current, High Level	I _{IH}	IN ₁ , IN _{2A} , IN _{2B} = 5 V		0.02		
Switches 1&2 – High Side Configuration						
Rise Time (Off to On)	t _r	R _{LOAD} = 250 Ω to GND, C ₁ , C ₂ = 25 V		300		ns
Rise Tiem (On to Off)	t _f			300		
Saturation Voltage	V _{SATHS}	R _{LOAD} = 125 Ω to GND			1.3	V
Current Limit	I _{LIMHS}	R _{LOAD} = 0.25 Ω to GND, T _A = 25 °C		1.1		A
Leakage Current	I _{LHS}	E ₁ , E ₂ = GND, C ₁ , C ₂ = 25 V, IN ₁ , IN _{2A} , IN _{2B} = 0 V			5	μA
Voltabe Clamp	V _{CLHS}	Measure (V _{C1} - V _{E1}) or (V _{C2} - V _{E2})		52		V
Switches 1&2 – Low Side Configuration						
Rise Time (On to Off)	t _r	R _{LOAD} = 250 Ω to V _{CC} , L _{LOAD} = 25 V to C ₁ , C ₂		400		ns
Rise Tiem (Off to On)	t _f				350	
Saturation Voltage	V _{SATLS}	R _{LOAD} = 125 Ω to V _{CC}			1.3	V
Current Limit	I _{LIMLS}	R _{LOAD} = 0.25 Ω to V _{CC} , T _A = 25 °C		1.1		A
Leakage Current	I _{LLS}	E ₁ , E ₂ = GND, C ₁ , C ₂ = 25 V, IN ₁ , IN _{2A} , IN _{2B} = 0 V			5	μA
Voltabe Clamp	V _{CLLS}	Measure (V _{C1} - V _{E1}) or (V _{C2} - V _{E2})		52		V
Turn-On Delay						
C _{DEL} Maximum Voltage	V _{DEL}			4.7		V
C _{DEL} Threshold	V _{DELTH}			4		
I _{CDEL}	I _{CDEL}			2.5		μA



New Product

SiP43101
Vishay Siliconix

SPECIFICATIONS						
Parameter	Symbol	Test Conditions Unless Specified $V_{CC} = 25\text{ V}, IN_1, IN_2 = 0\text{ V}, IN_1, IN_2, INV_2 = 5\text{ V}$ $C_{DEL} = 10\text{ nF}, T_A = T_J$	Limits			Unit
			Min ^a	Typ ^b	Max ^a	
FAULT Output						
V_{CESAT} Conducting State (On)	V_{SDON}	10 mA Load on $\overline{\text{FAULT}}$		0.4		V
Operating Frequency						
Switching Frequency	f_{sw}			25		kHz
Under Voltage Lockout						
UVLO Threshold	V_{UVLO}		7.5	8	8.5	V
UVLO Hysteresis	V_{HYS}		0.4	0.5	0.6	
Thermal Shutdown						
Thermal Shutdown Threshold	T			160		°C
Hysteresis	T_{HYS}			20		

Notes

- a. The algebraic convention whereby the most negative value is a minimum and the most positive a maximum (-40° to 85°C).
- b. Typical values are for DESIGN AID ONLY, not guaranteed nor subject to production testing and are measured at $V_{CC} = 12\text{ V}$ unless otherwise noted.

PIN CONFIGURATION

TSSOP-16

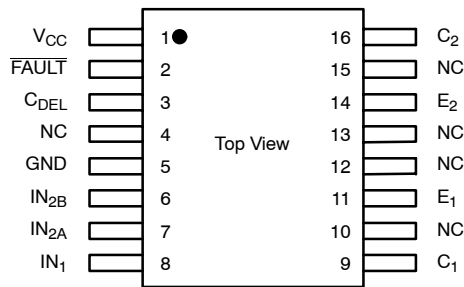

TSSOP-16 ORDERING INFORMATION

Part Number	Temperature Range	Marking
SiP43101DQ-T1	-40 to 85°C	43101

PowerPAK MLP-44

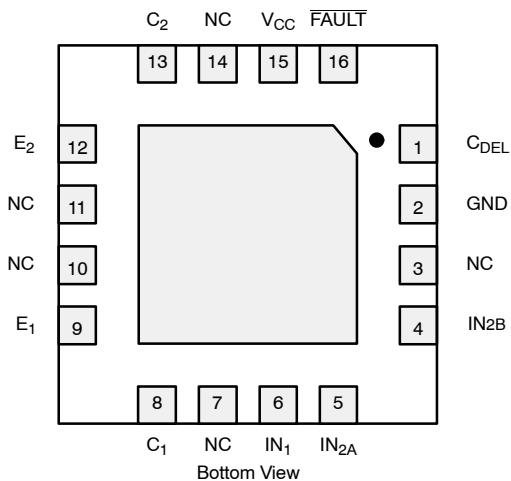

PowerPAK MLP-44 ORDERING INFORMATION

Part Number	Temperature Range	Marking
SiP43101DLP-T1	-40 to 85°C	43101



PIN DESCRIPTION			
Pin Number		Name	Function
TSSOP-16	MLP44-16		
1	15	V _{CC}	Positive Supply Voltage
2	16	$\overline{\text{FAULT}}$	Open collector output that is switched low on in the event of Short Circuit or Thermal Shut Down.
3	1	C _{DEL}	Connection for the external capacitor controlling the turn on delay.
4, 10, 12, 13, 15	3, 7, 10, 11, 14	NC	No connection
5	2	GND	Ground Pin.
6	4	IN _{2B}	Input to the Exclusive OR controlling power switch 2.
7	5	IN _{2A}	Input to the Exclusive OR controlling power switch 2.
8	6	IN ₁	Input controlling power switch 1.
9	8	C ₁	Collector of power switch 1.
11	9	E ₁	Emitter of power switch 1.
14	12	E ₂	Emitter of power switch 2.
16	13	C ₂	Collector of power switch 2.

DETAILED PIN DESCRIPTION

C_{DEL}

A capacitor connected to this pin is used to set the duration the turn on delay. The delay starts after the UVLO threshold has been reached.

IN₁

This pin controls the state of the output NPN switch 1. A Logic 0 holds the switch off while a Logic 1 turns the switch on.

IN_{2A}, IN_{2B}

These pins are the inputs to the Exclusive OR gate that controls the state of the output NPN switch 2. This allows the use of either a non-inverting or an inverted signal to control the switch. Refer to the truth table for the logic function description.

IN _{2A}	IN _{2B}	SWITCH 2
Low	Low	Off
Low	High	On
High	Low	On
High	High	Off

E₁

This pin is the emitter of Switch 1. This pin is connected to the load in the High-Side Switch configuration, and is connected to Ground in the Low-Side configuration.

E₂

This pin is the emitter of switch 2. This pin is connected to the load in the High-Side switch configuration, and is connected to Ground in the Low-Side configuration.

C₁

This pin is the collector of switch 1. This pin is connected to the V_{CC} in the High-Side switch configuration, and is connected to the load in the Low-Side configuration.

C₂

This pin is the collector of switch 2. This pin is connected to the V_{CC} in the High-Side switch configuration, and is connected to the load in the Low-Side configuration.

$\overline{\text{FAULT}}$

This pin is an open collector output that is pulled to Ground in the event of a short circuit, an overcurrent, or a thermal shut down

FUNCTIONAL BLOCK DIAGRAM

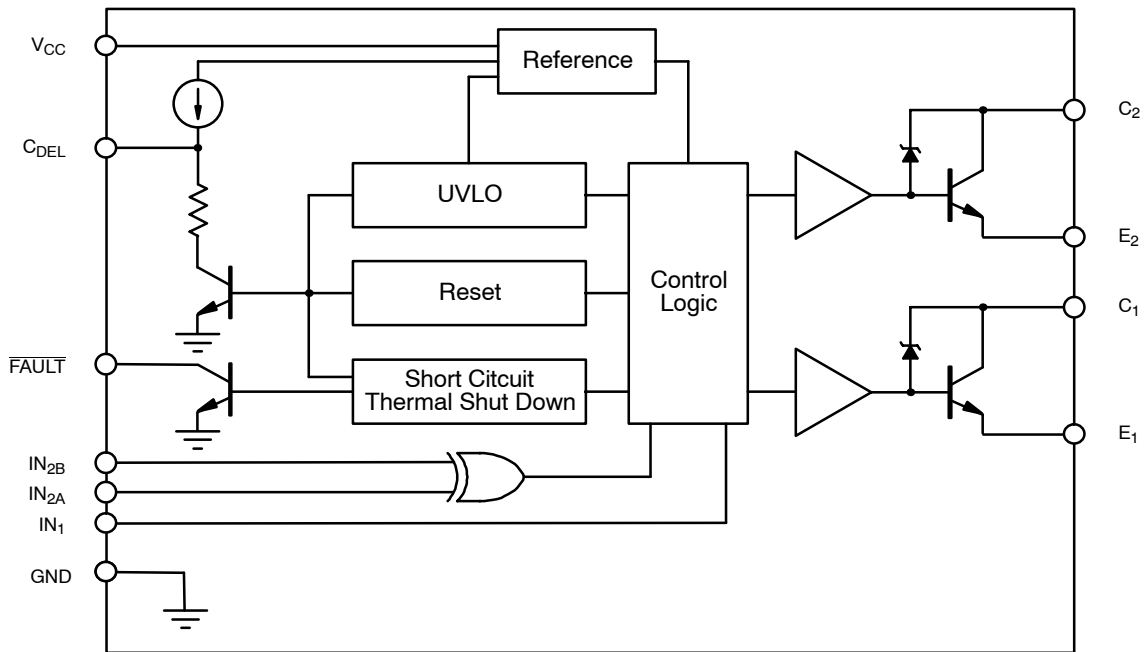

DETAILED OPERATION

Turn On Delay

The turn on delay prohibits the output switches from being turned on for a period of time after V_{CC} has passed through 8 V and the undervoltage condition no longer exists. The UVLO function keeps the external C_{DEL} capacitor discharged until V_{CC} is greater than 8 V. Subsequently, an internal 2.5- μ A current source charges the capacitor from GND to 4.7 V. A comparator detects when the voltage on C_{DEL} passes through 4 V and enables the output switches. The delay time is a function of the capacitor value and is defined as 1.6 ms/nF.

An external switch can be connected across the capacitor to disable the output switches and reset the time delay.

Short Circuit and Overcurrent indication

When an overcurrent or short circuit condition occurs on either switch, the SiP43101 enters a hiccup current limiting mode. In this mode, the capacitor on C_{DEL} is discharged down to 3 V, thus turning off the output switches, and then is charged up to 4 V by a 2.5- μ A internal current source, thus turning the switches on again. If the overcurrent or short circuit condition remains this cycle will continue. The switches are enabled at a very low duty cycle, minimizing the power dissipation and protecting the switches from damage.

The FAULT output will switch to GND, indicating that an overload condition or short circuit condition exists.