



SL2524

1.3GHz Dual Wideband Logarithmic Amplifier

DS4548 - 2.1 July 1995

The SL2524 is a pin compatible replacement for the SL2521 and SL2522 series of log amplifiers, and exhibits a superior stability performance. The amplifier is a successive detection type which provides linear gain and accurate logarithmic signal compression over a wide bandwidth. The two stages can be operated independently.

When six stages (three SL2524s) are cascaded the strip can be used for IFs between 30-650MHz whilst achieving greater than 65dB dynamic range with a log accuracy of $<\pm 1.0\text{dB}$. The balanced limited output also offers accurate phase information with input amplitude.

FEATURES

- 1.3GHz Bandwidth (-3dB)
- Balanced IF limiting
- 3ns Rise Times/5ns Fall Times (six stages)
- 20ns Pulse Handling (six stages)
- Temperature Stabilised
- Surface Mountable

APPLICATIONS

- Ultra Wideband Log Receivers
- Channelised Receivers
- Monopulse Applications

ABSOLUTE MAXIMUM RATINGS

Supply Voltage (V_{CC} above V_{EE})	+7.0V
Storage temperature	-65°C to +150°C
Operating temperature range	
SL2524/B/LC	-40°C to +85°C
SL2524/C/HP	-30°C to +85°C
Junction temperature - LC20	+175°C
- HP20	+150°C
Applied DC voltage to RF input	$\pm 0.4\text{V}$ (between RF I/P pins)
Applied RF power to RF input	+15dBm
Value of R_{SET} resistors	NOT less than 180Ω
Thermal resistance:-	
Die to case - LC 20	28°C/W
- HP20	20°C/W
Die to ambient - LC20	73°C/W
- HP20	82°C/W

ORDERING INFORMATION

- SL2524/B/LC (Ceramic leadless chip carrier package)
- SL2524/C/HP (Plastic J lead chip carrier package)
- SL2524/NA/1C (DC probe tested bare die)
- 5962 - 92315 (SMD)

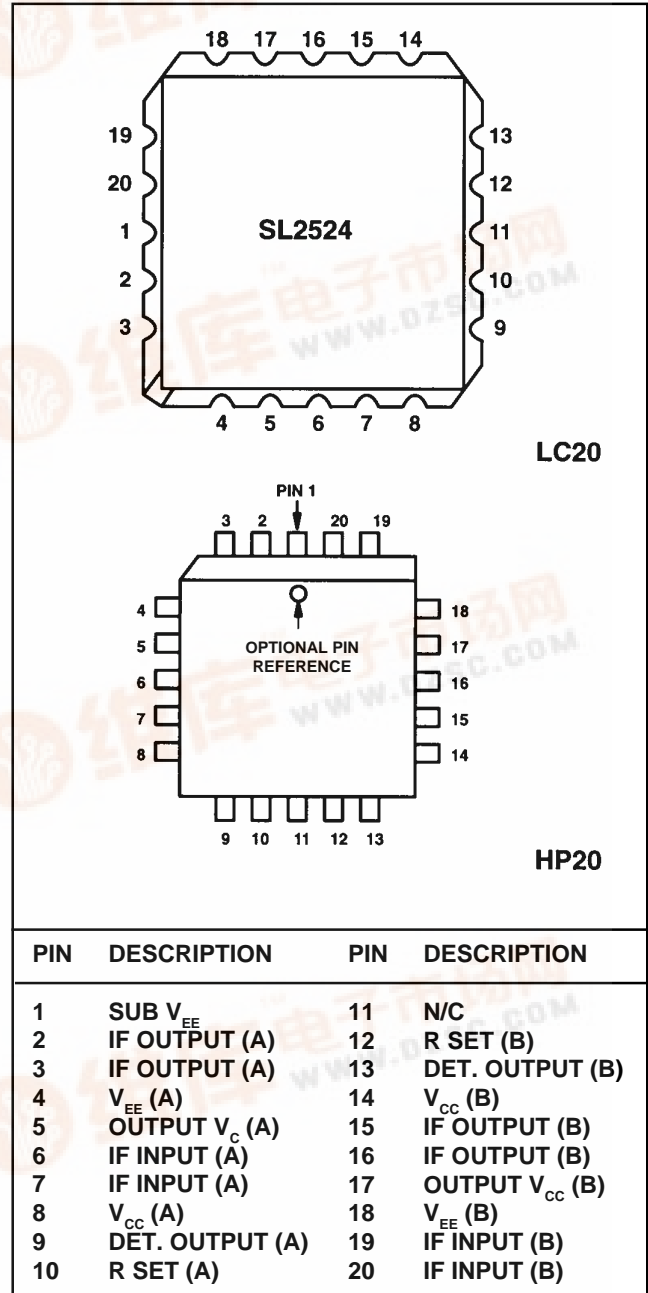

Fig.1 Pin connections top view



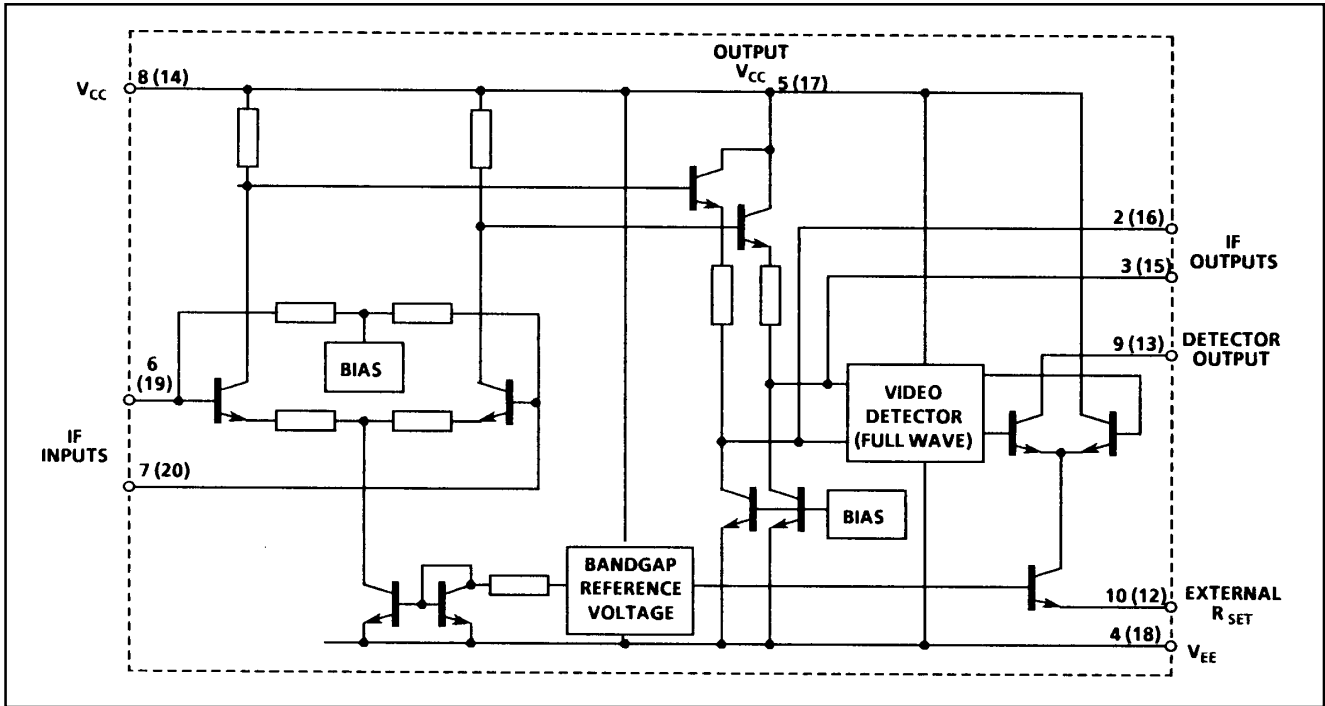

Fig.2 Circuit diagram of single stage A - (stage B pin Nos bracketed)

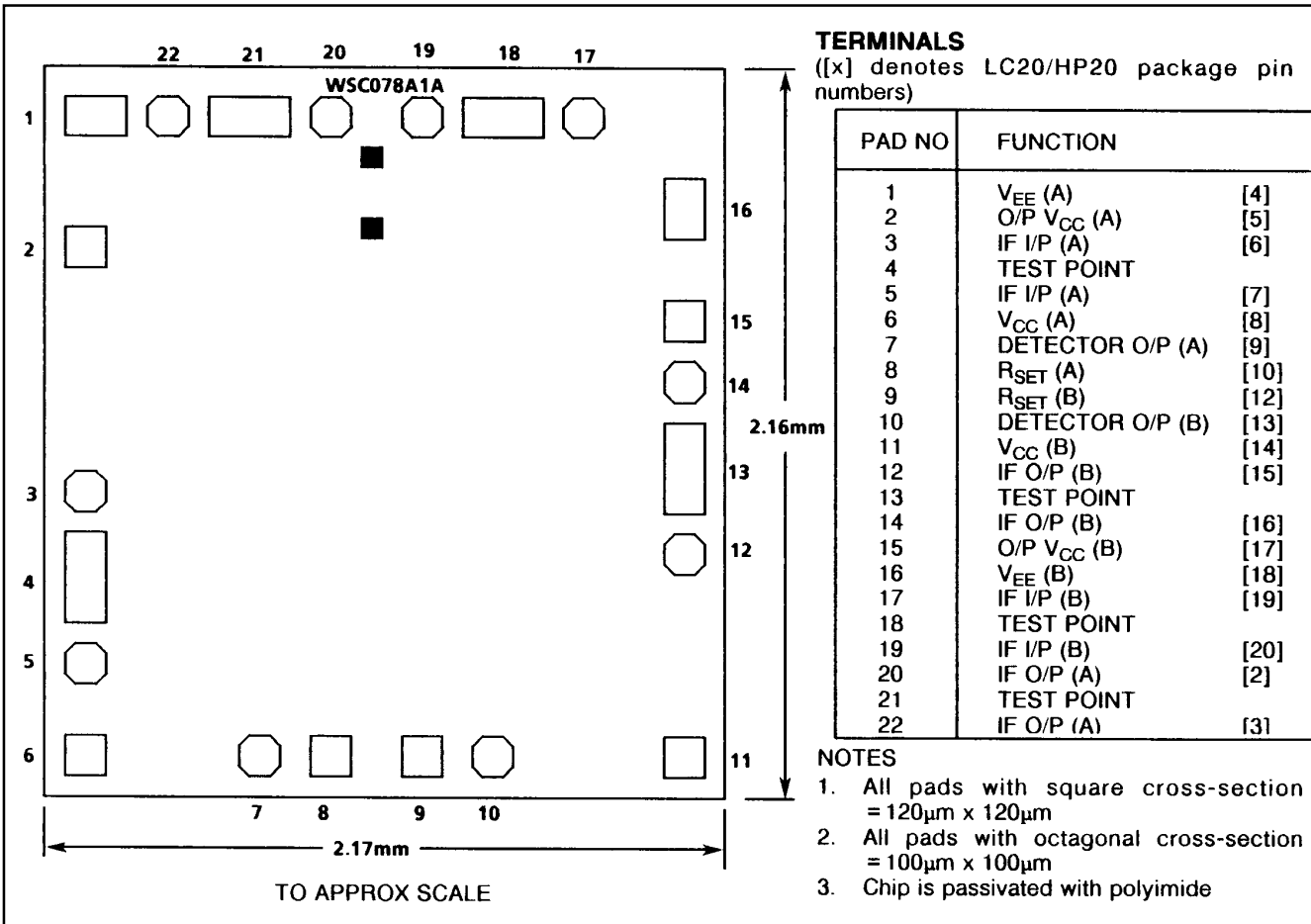

Fig.3 Pad map for SL2524 naked die

ELECTRICAL CHARACTERISTICS - SL2524B**Guaranteed at the following test conditions unless otherwise stated**Frequency = 200MHz, $T_{amb} = +25^{\circ}\text{C}$, Input power = -30dBm, $V_{CC} = 6V \pm 0.1V$, Source Impedance = 50 Ω .Load impedance = 50 Ω , Test Circuit = Fig. 4, $R_{SET} = 300\Omega$. Tested as a dual stage.

Characteristic	Value			Units	Conditions
	Min	Typ	Max		
Supply current	70	87	100	mA	
Small signal gain (dual stage, single ended)	9.6	11.4	13.0	dB	$T_{amb} = +25^{\circ}\text{C}$, $f = 25\text{MHz}$ See Notes 1, 3
	10.1	11.6	13.1	dB	$T_{amb} = -40^{\circ}\text{C}$, $f = 200\text{MHz}$ See Notes 2, 3
	9.9	11.3	12.7	dB	$T_{amb} = +25^{\circ}\text{C}$, $f = 200\text{MHz}$ See Note 3
	9.5	11.0	12.5	dB	$T_{amb} = +85^{\circ}\text{C}$, $f = 200\text{MHz}$ See Notes 2, 3
	9.7	11.2	12.7	dB	$T_{amb} = -40^{\circ}\text{C}$, $f = 500\text{MHz}$ See Notes 2, 3
	9.3	10.7	12.1	dB	$T_{amb} = +25^{\circ}\text{C}$, $f = 500\text{MHz}$ See Note 3
	8.2	9.7	11.2	dB	$T_{amb} = +85^{\circ}\text{C}$, $f = 500\text{MHz}$ See Notes 2, 3
Detected output current (max)	3.20	3.45	3.70	mA	$T_{amb} = +25^{\circ}\text{C}$, $V_{IN} = 0\text{dBm}$, $f = 25\text{MHz}$ See Note 1
	3.05	3.25	3.45	mA	$T_{amb} = -40^{\circ}\text{C}$, $V_{IN} = 0\text{dBm}$, $f = 200\text{MHz}$ See Note 2
	3.15	3.30	3.45	mA	$T_{amb} = +25^{\circ}\text{C}$, $V_{IN} = 0\text{dBm}$, $f = 200\text{MHz}$
	3.10	3.30	3.50	mA	$T_{amb} = +85^{\circ}\text{C}$, $V_{IN} = 0\text{dBm}$, $f = 200\text{MHz}$ See Note 2
	2.80	3.10	3.30	mA	$T_{amb} = -40^{\circ}\text{C}$, $V_{IN} = 0\text{dBm}$, $f = 500\text{MHz}$ See Note 2
	2.90	3.15	3.45	mA	$T_{amb} = +25^{\circ}\text{C}$, $V_{IN} = 0\text{dBm}$, $f = 500\text{MHz}$
	2.85	3.10	3.65	mA	$T_{amb} = +85^{\circ}\text{C}$, $V_{IN} = 0\text{dBm}$, $f = 500\text{MHz}$ See Note 2
Detected output current (no signal)	0.85	0.95	1.15	mA	$T_{amb} = -40^{\circ}\text{C}$, See Note 2
	0.80	0.93	1.10	mA	$T_{amb} = +25^{\circ}\text{C}$, See Note 2
	0.80	0.90	1.10	mA	$T_{amb} = +85^{\circ}\text{C}$, See Note 2
Upper cut off frequency (RF)	600	1100		MHz	-3dB w.r.t 200MHz, $T_{amb} = -40^{\circ}\text{C}$ See Note 2
	900	1100		MHz	-3dB w.r.t 200MHz, $T_{amb} = +25^{\circ}\text{C}$
	600	800		MHz	-3dB w.r.t 200MHz, $T_{amb} = +85^{\circ}\text{C}$ See Note 2
Lower cut off frequency (RF)		0.35	1	MHz	-3dB w.r.t 200MHz, $T_{amb} = +25^{\circ}\text{C}$
Detector cut off frequency		700		MHz	50% O/P current w.r.t. 200MHz
Limited IF O/P voltage	135	155	175	mV	I/P power = 0dBm, $T_{amb} = +25^{\circ}\text{C}$
Phase variation with input level (normalised to -30dBm)		0 \pm 2.0	0 \pm 3.0	Degree	Frequency = 70MHz, -55 to +3dBm See Note 2
		-4.0 \pm 2.0	-4.0 \pm 3.0	Degree	Frequency = 200MHz, -55 to +3dBm See Note 2
Limited O/P var with temp.		\pm 12	\pm 25	mV	See Note 1
Noise figure		14		dB	
Max I/P before overload		15		dBm	
Input impedance		1		k Ω	1k Ω in parallel with 2pF
Output impedance		50		Ω	

NOTES

- Parameter guaranteed but not tested
- Tested at 25 $^{\circ}\text{C}$ only, but guaranteed at temperature
- Gain will typically increase by 6dB, when RF outputs use 1k Ω loads in place of 50 Ω

SL2524

ELECTRICAL CHARACTERISTICS - SL2524C

Guaranteed at the following test conditions unless otherwise stated

Frequency = 200MHz, $T_{amb} = +25^{\circ}\text{C}$, Input power = -30dBm, $V_{CC} = 6V \pm 0.1V$, Source Impedance = 50 Ω .
Load impedance = 50 Ω , Test Circuit = Fig. 4, $R_{SET} = 300\Omega$. Tested as a dual stage.

Characteristic	Value			Units	Conditions
	Min	Typ	Max		
Supply current	70	87	100	mA	
Small signal gain (dual stage, single ended)	9.6	11.4	13.0	dB	$T_{amb} = +25^{\circ}\text{C}$ f = 25MHz See Note 3
	9.6	11.6	13.6	dB	$T_{amb} = -30^{\circ}\text{C}$ f = 200MHz See Notes 2, 3
	9.4	11.3	13.2	dB	$T_{amb} = +25^{\circ}\text{C}$ f = 200MHz See Note 3
	9.0	11.0	13.0	dB	$T_{amb} = +85^{\circ}\text{C}$ f = 200MHz See Notes 2, 3
	9.2	11.2	13.2	dB	$T_{amb} = -30^{\circ}\text{C}$ f = 500MHz See Notes 1, 3
	8.8	10.7	12.6	dB	$T_{amb} = +25^{\circ}\text{C}$ f = 500MHz See Note 1
	7.7	9.7	11.7	dB	$T_{amb} = +85^{\circ}\text{C}$ f = 500MHz See Notes 1, 3
Detected output current (max)	3.20	3.45	3.70	mA	$T_{amb} = +25^{\circ}\text{C}$, $V_{IN} = 0\text{dBm}$, f = 25MHz
	2.95	3.25	3.55	mA	$T_{amb} = -30^{\circ}\text{C}$, $V_{IN} = 0\text{dBm}$, f = 200MHz
					See Note 2
	3.05	3.30	3.55	mA	$T_{amb} = +25^{\circ}\text{C}$, $V_{IN} = 0\text{dBm}$, f = 200MHz
	3.00	3.30	3.50	mA	$T_{amb} = +85^{\circ}\text{C}$, $V_{IN} = 0\text{dBm}$, f = 200MHz
					See Note 2
	2.70	3.10	3.30	mA	$T_{amb} = -30^{\circ}\text{C}$, $V_{IN} = 0\text{dBm}$, f = 500MHz
				See Note 1	
				$T_{amb} = +25^{\circ}\text{C}$, $V_{IN} = 0\text{dBm}$, f = 500MHz	
				See Note 1	
				$T_{amb} = +85^{\circ}\text{C}$, $V_{IN} = 0\text{dBm}$, f = 500MHz	
				See Note 1	
Detected output current (no signal)	0.75	0.95	1.25	mA	$T_{amb} = -30^{\circ}\text{C}$, See Note 2
	0.70	0.93	1.20	mA	$T_{amb} = +25^{\circ}\text{C}$, See Note 2
	0.70	0.90	1.20	mA	$T_{amb} = +85^{\circ}\text{C}$, See Note 2
Upper cut off frequency (RF)		1000		MHz	-3dB w.r.t 200MHz, $T_{amb} = +25^{\circ}\text{C}$ See Note 1
Lower cut off frequency (RF)		0.35	2	MHz	-3dB w.r.t 200MHz, $T_{amb} = +25^{\circ}\text{C}$
Detector cut off frequency		600		MHz	50% O/P current w.r.t. 200MHz
Limited IF O/P voltage	105	135	175	mV	I/P power = 0dBm, $T_{amb} = +25^{\circ}\text{C}$
Phase variation with input level (normalised to -30dBm)		0 \pm 2.0		Degree	Frequency = 70MHz, -55 to +3dBm See Note 1
		-4.0 \pm 2.0		Degree	Frequency = 200MHz, -55 to +3dBm See Note 1
Limited O/P var with temp.		\pm 12	\pm 25	mV	See Note 1
Noise figure		14		dB	
Max I/P before overload		15		dBm	
Input impedance		1		k Ω	1k Ω in parallel with 2pF
Output impedance		50		Ω	

NOTES

- Parameter guaranteed but not tested
- Tested at 25 $^{\circ}\text{C}$ only, but guaranteed at temperature
- Gain will typically increase by 6dB, when RF outputs use 1k Ω loads in place of 50 Ω

GENERAL DESCRIPTION

The SL2524 is primarily intended for use in Radar and EW receivers. Six stages (3 chip carriers) can be cascaded to form a very wideband logarithmic amplifier offering >65dB of input dynamic range, with pulse handling of better than 25ns. (See figs 5 and 6.)

A six stage strip also offers balanced IF limiting, linearity (log accuracy) of $< \pm 1.0\text{dB}$, temperature stabilisation and programmable detector characteristics.

The detector has an external resistor set (R_{SET}) pin which allows the major characteristics of the detector to be programmed. With six stage strip it is possible to vary the value of R_{SET} on each detector and so improve the overall log error/linearity.

The detector is full wave and good slew rates are achieved with 2ns rise and 5ns fall times (no video filter). The video bandwidth of a six stage strip is typically 600MHz (-3dB).

The amplifier also offers balanced IF limiting, low phase shift versus input amplitude, and at an IF of 120MHz, less than 5° of phase change is achievable over the input level of -55dBm to +5dBm.

The IF and Video ports can be used simultaneously, so offering phase, frequency and pulse (video) information. A slight loss of dynamic range (2dB) will be observed when the IF ports are used in conjunction with the video.

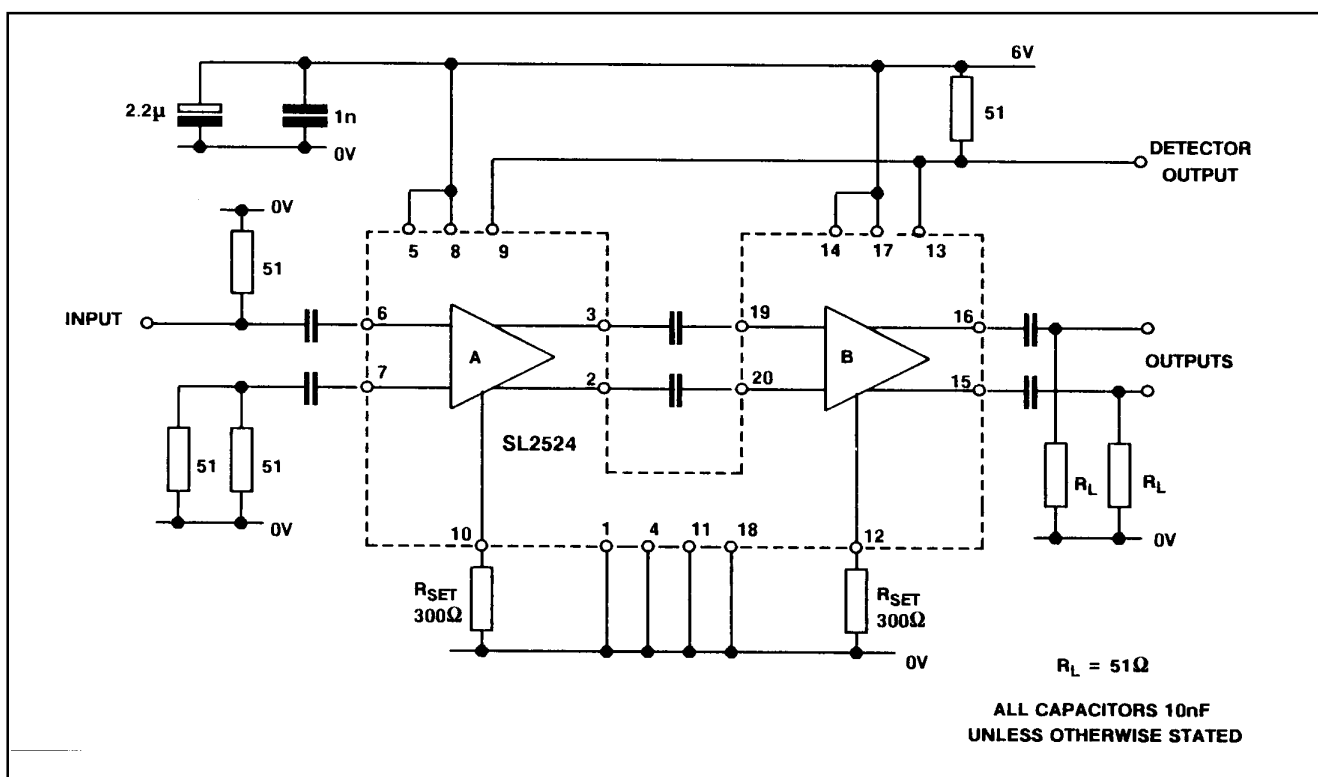

Fig.4 Test circuit

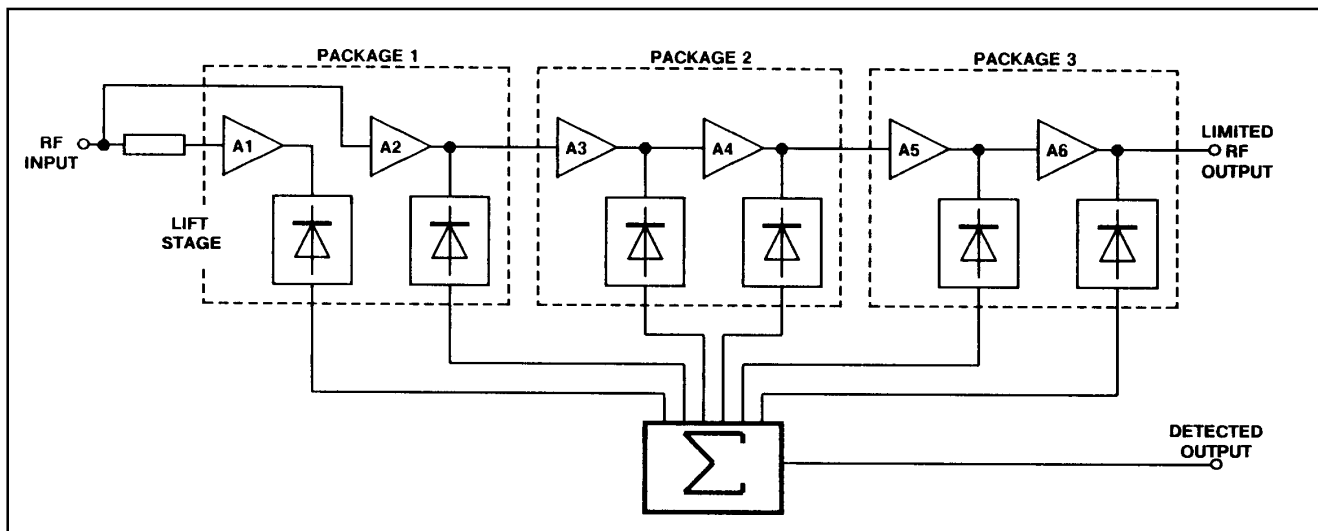

Fig.5 Schematic diagram showing configuration of SD Log strip

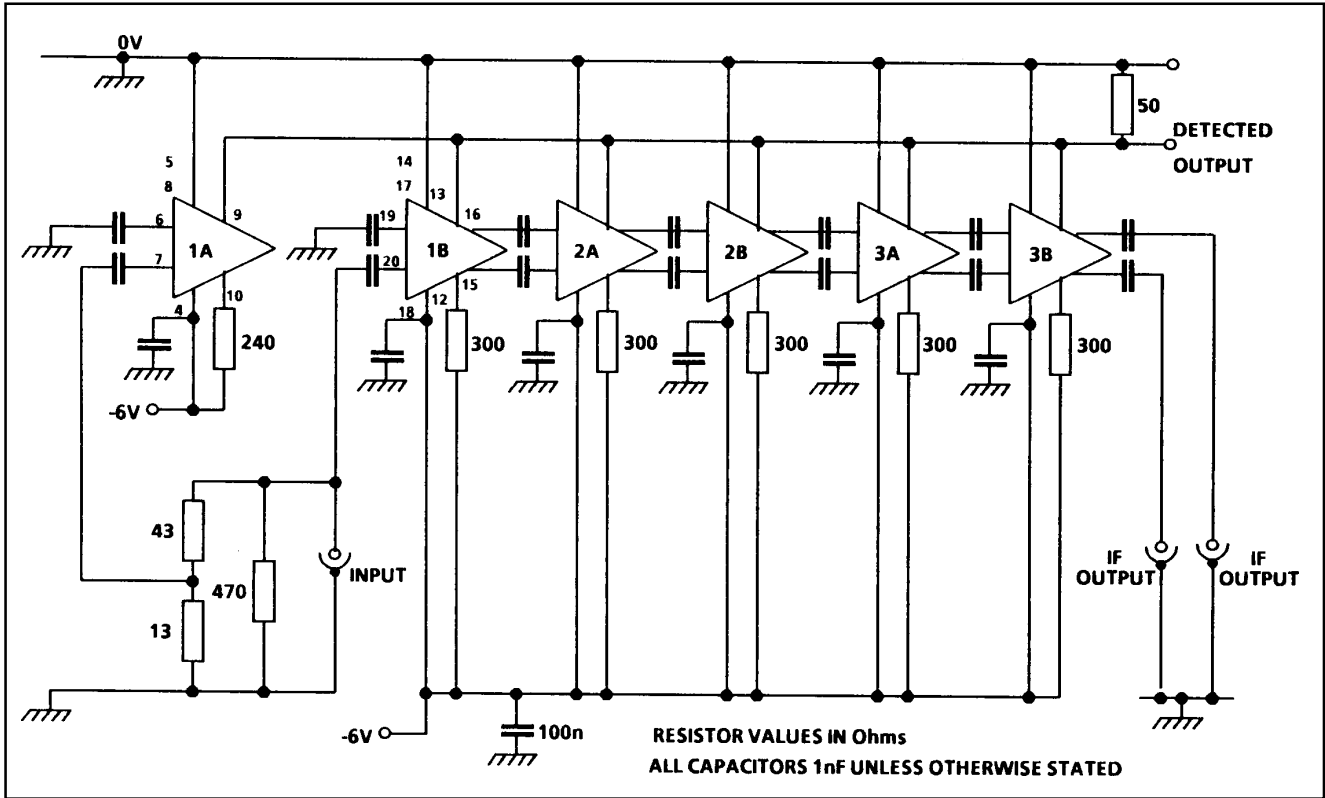

Fig.6 Circuit diagram for 6-log strip (results shown in figs. 11 to 24 were achieved with this circuit)

Typical characteristics for a dual - stage amplifier (i.e. One SL2524)

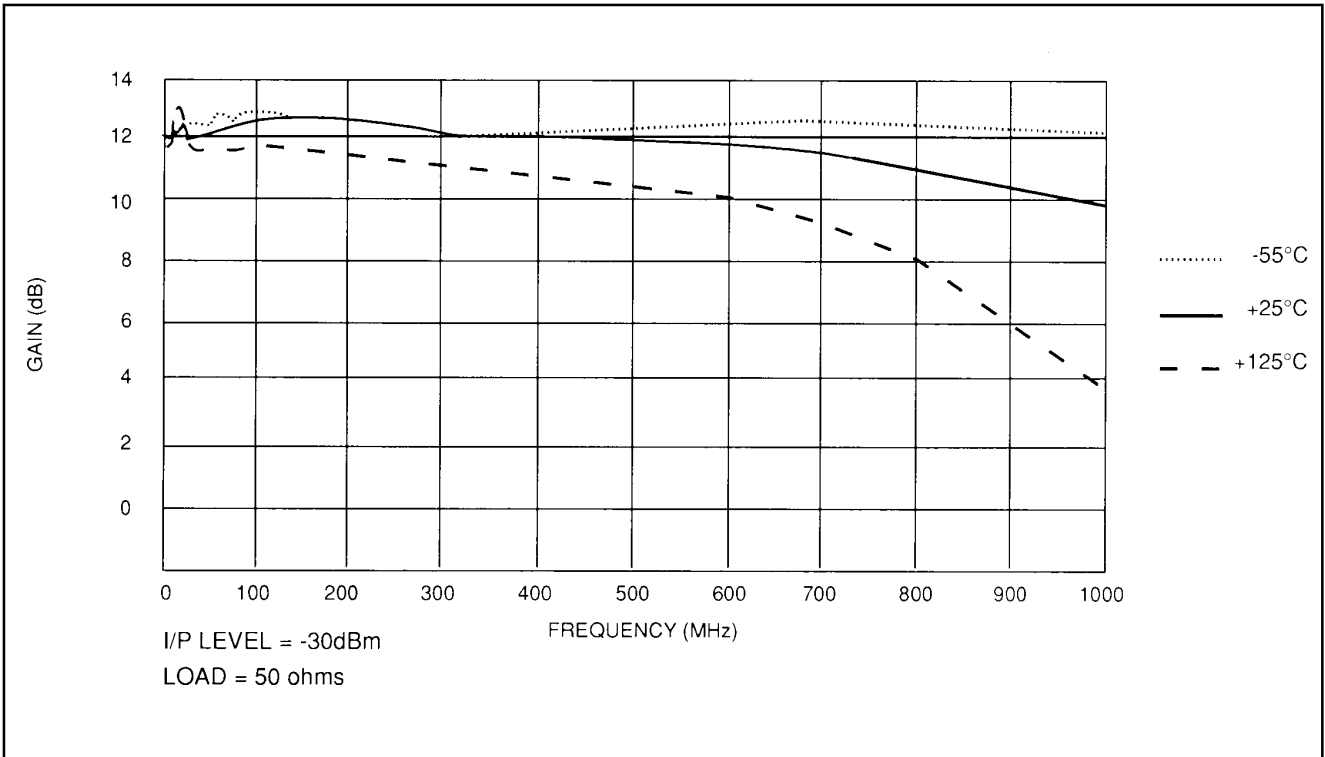

Fig.7 IF Gain vs frequency of 2 amplifiers (One SL2524)

Typical characteristics for a dual - stage amplifier (i.e. One SL2524) cont.

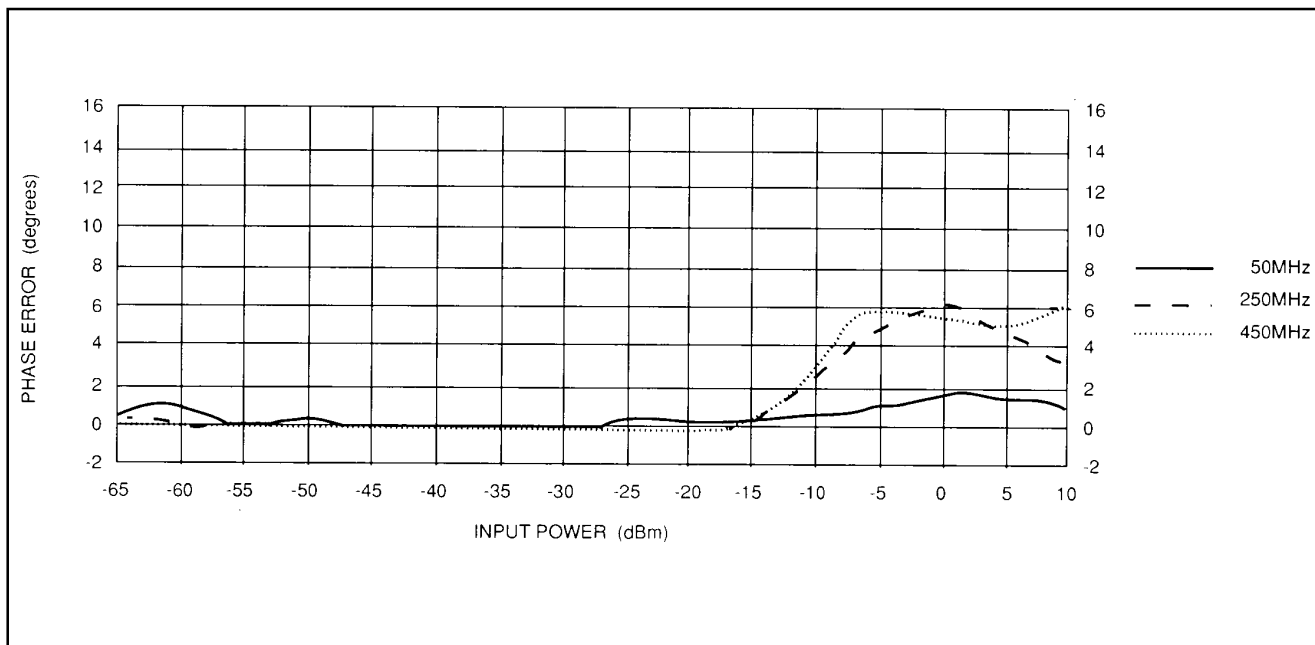

Fig.8 Normalised phase vs CW input level at 50, 250 and 450MHz for 50Ω O/P termination (25°C)

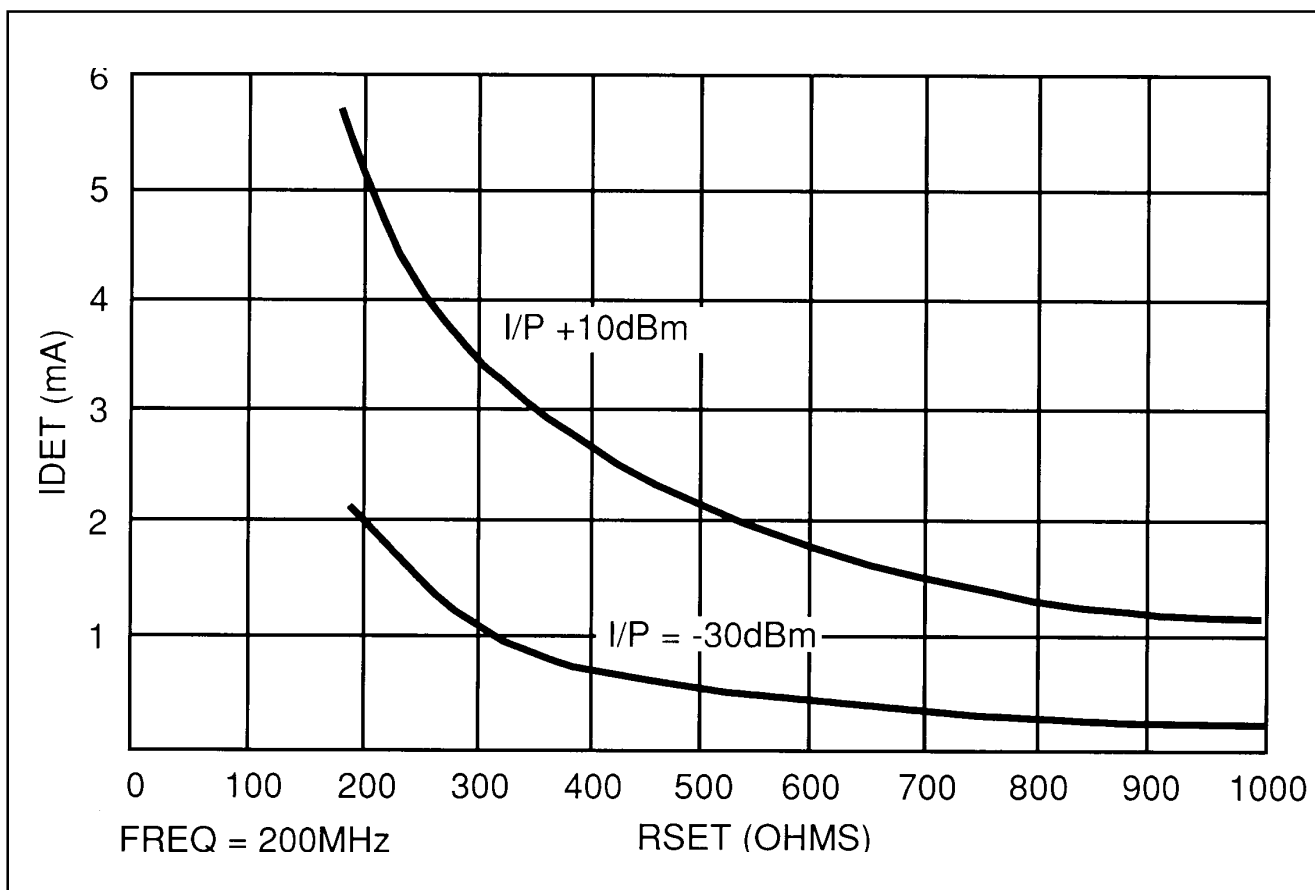

Fig.9 Detector current vs R_{SET} at 200MHz (25°C)

SL2524

Typical characteristics for a dual - stage amplifier (i.e. One SL2524) cont.

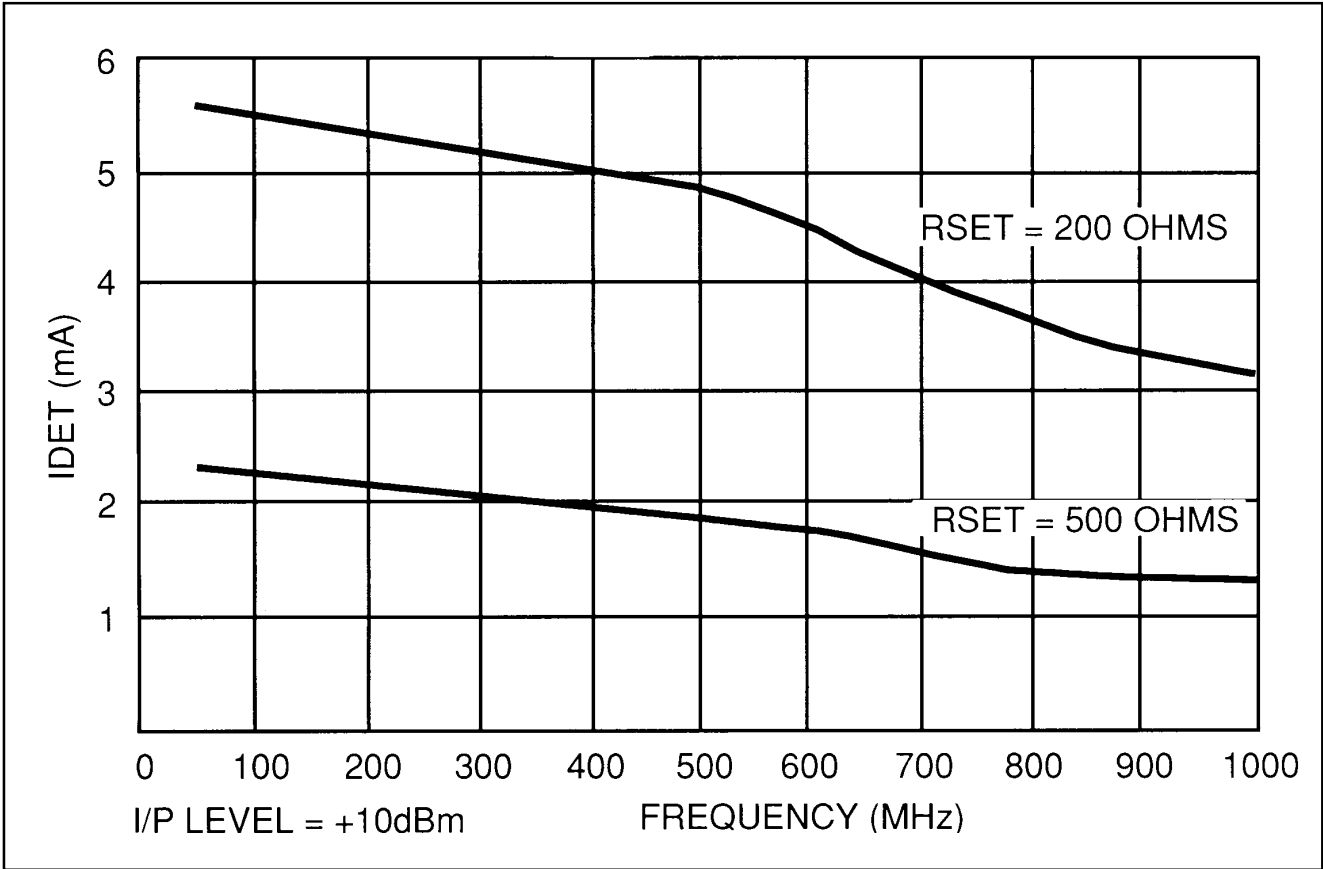

Fig.10 Detector current vs frequency at RSET = 200Ω and 500Ω (25°C)

Typical characteristics for a six stage strip, using detected output (Ref. figs 5 & 6)

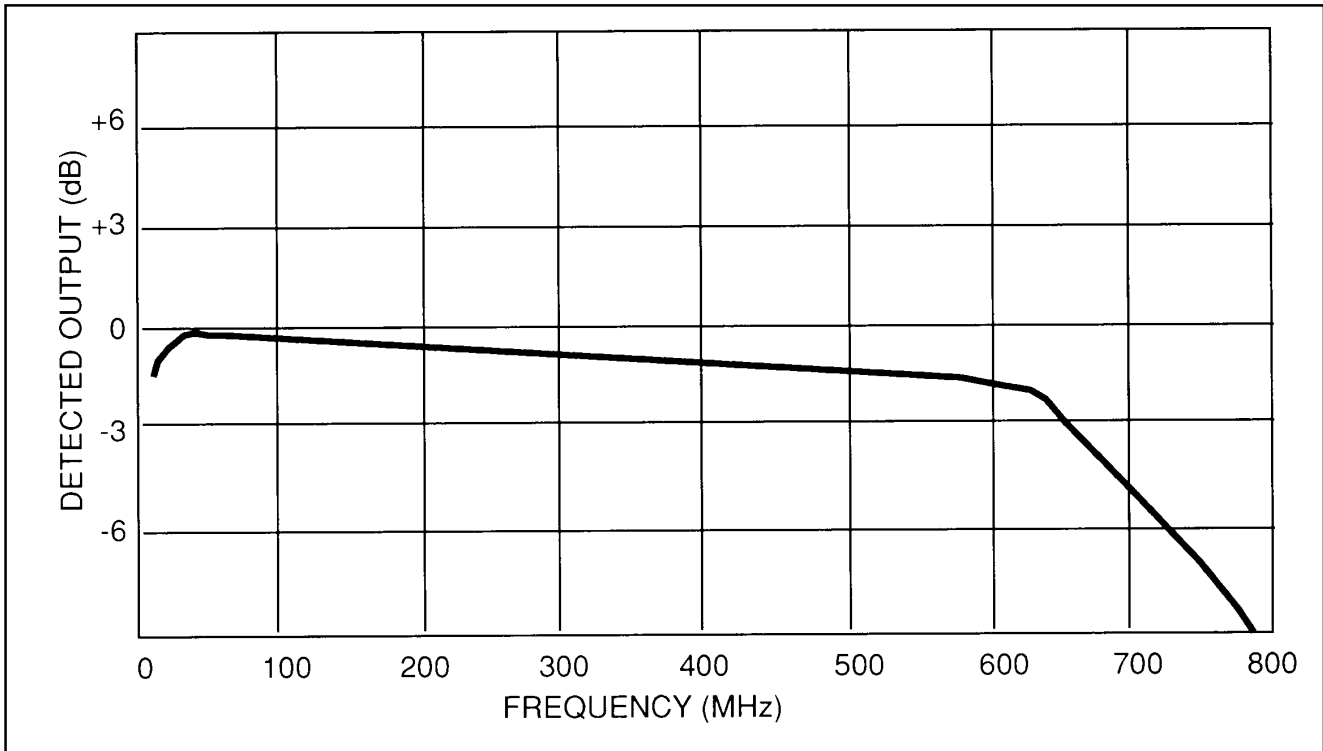

Fig.11 Detector bandwidth (25°C)

Typical characteristics for a six stage strip, using detected output (Ref. figs 5 & 6) cont.

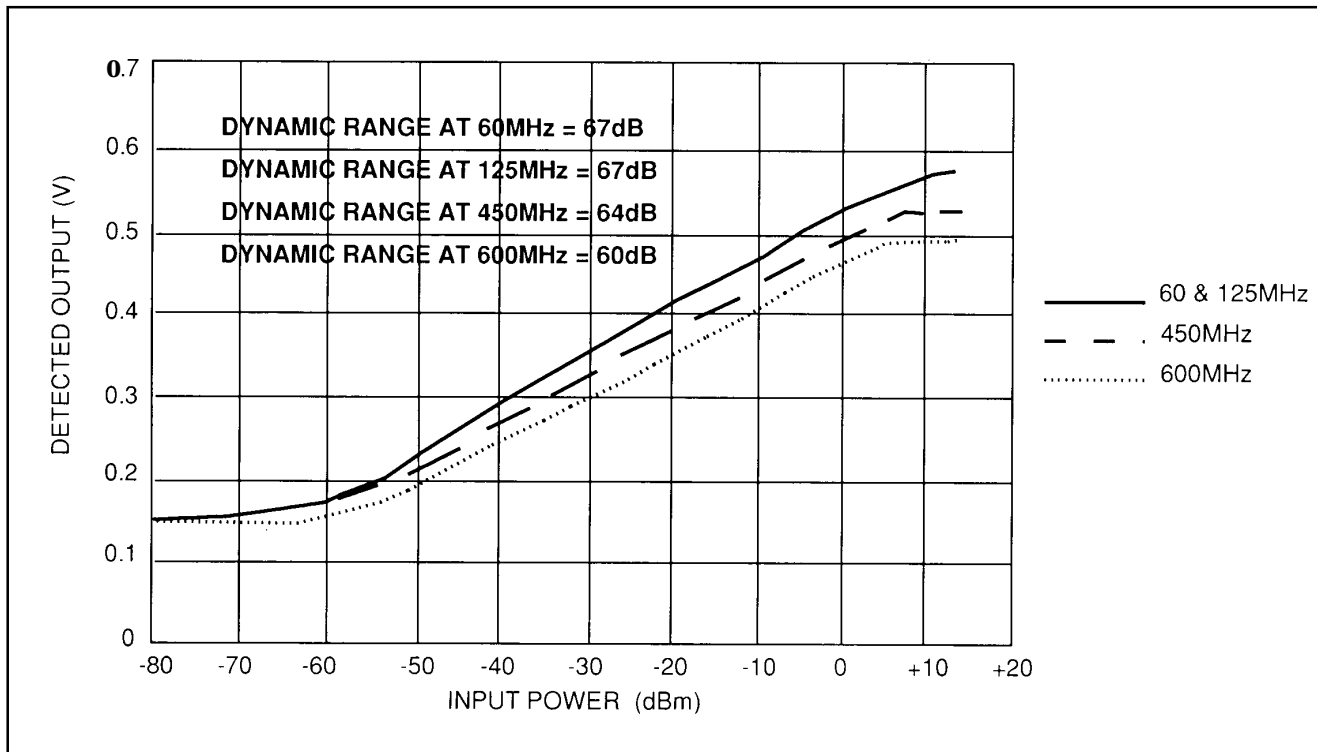

Fig.12 Detected O/P vs CW input at 60, 125, 450 and 600MHz at 25°C

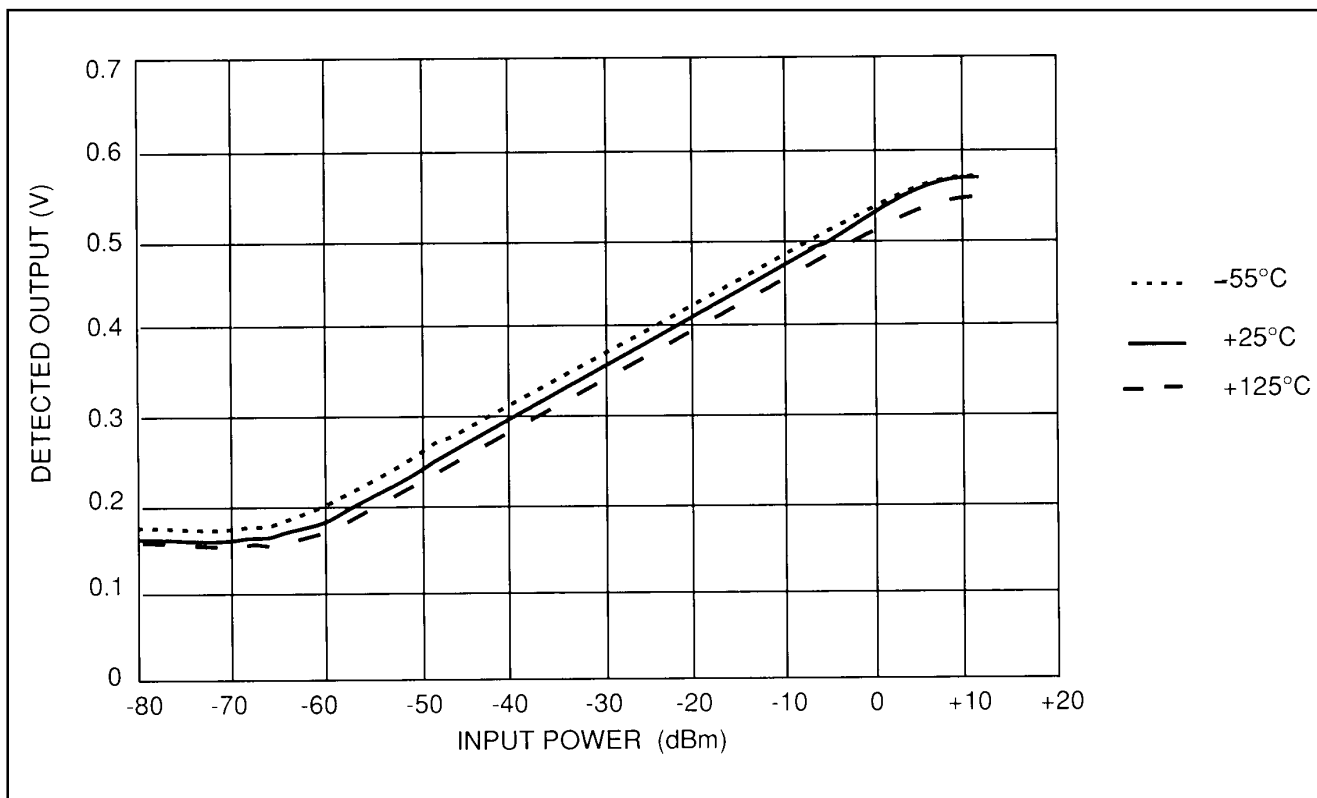

Fig.13 Detected O/P vs CW input level and temperature at 60 and 125MHz

Typical characteristics for a six stage strip, using detected output (Ref. figs 5 & 6) cont.

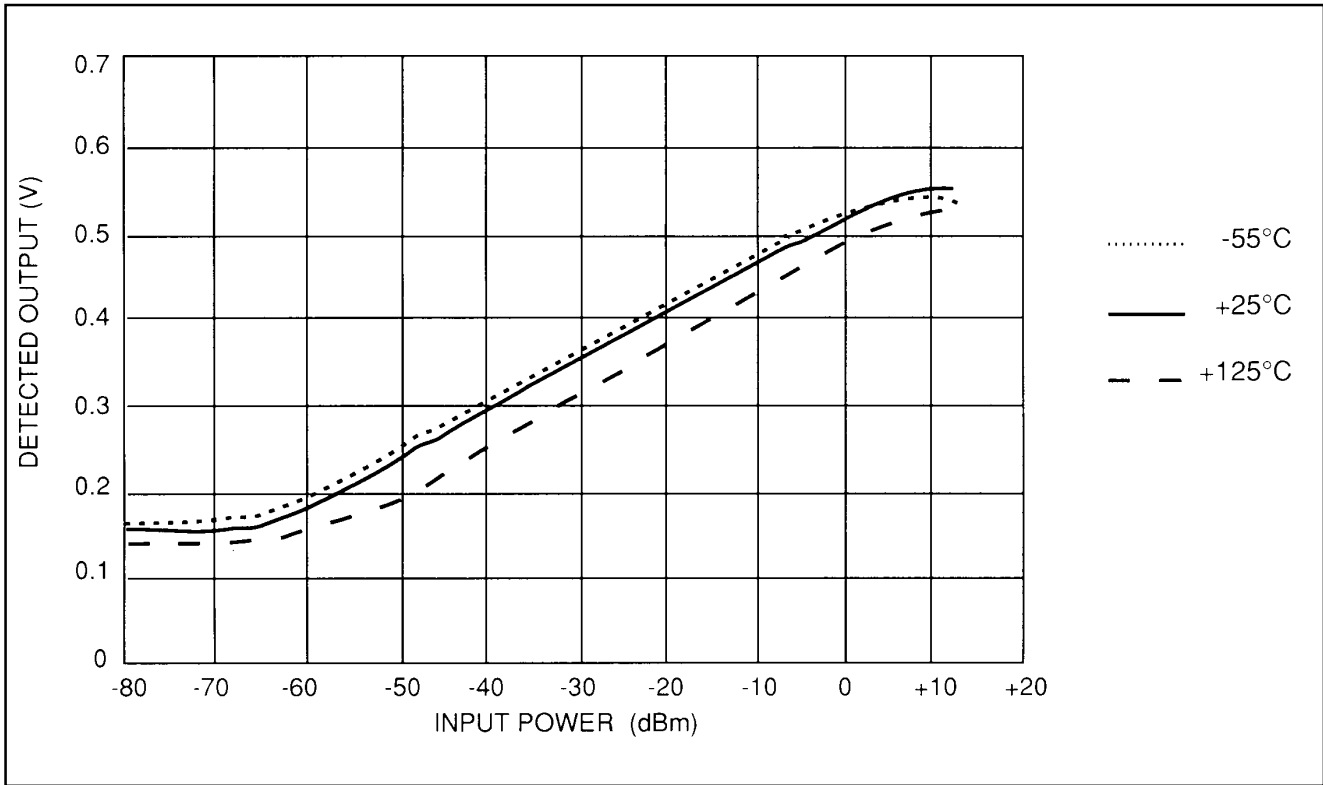

Fig.14 Detected O/P vs CW input level at 450MHz across temperature

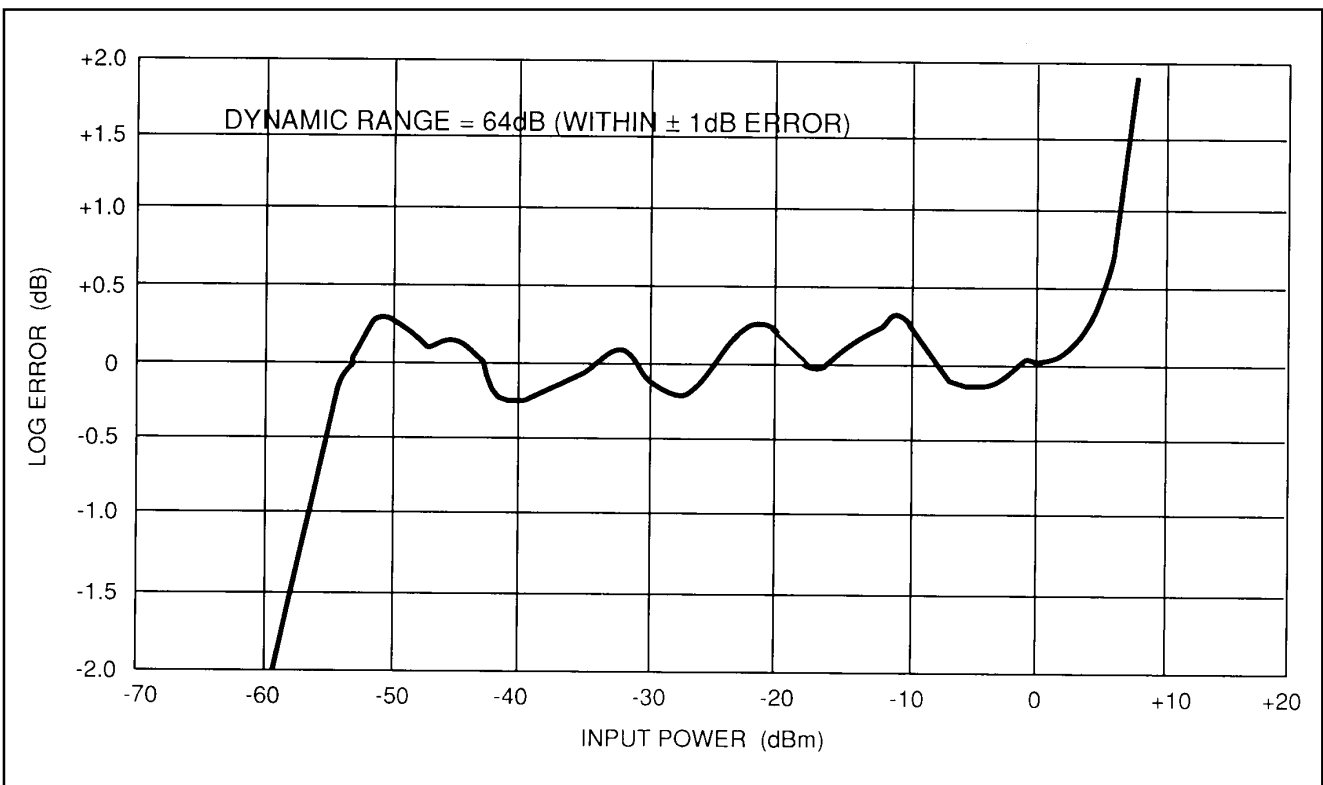

Fig.15 Typical log linearity of detected output measured at 450MHz (25°C)

Typical characteristics for a six stage strip as a low phase shift wideband limiter (Ref. figs 5 & 6)

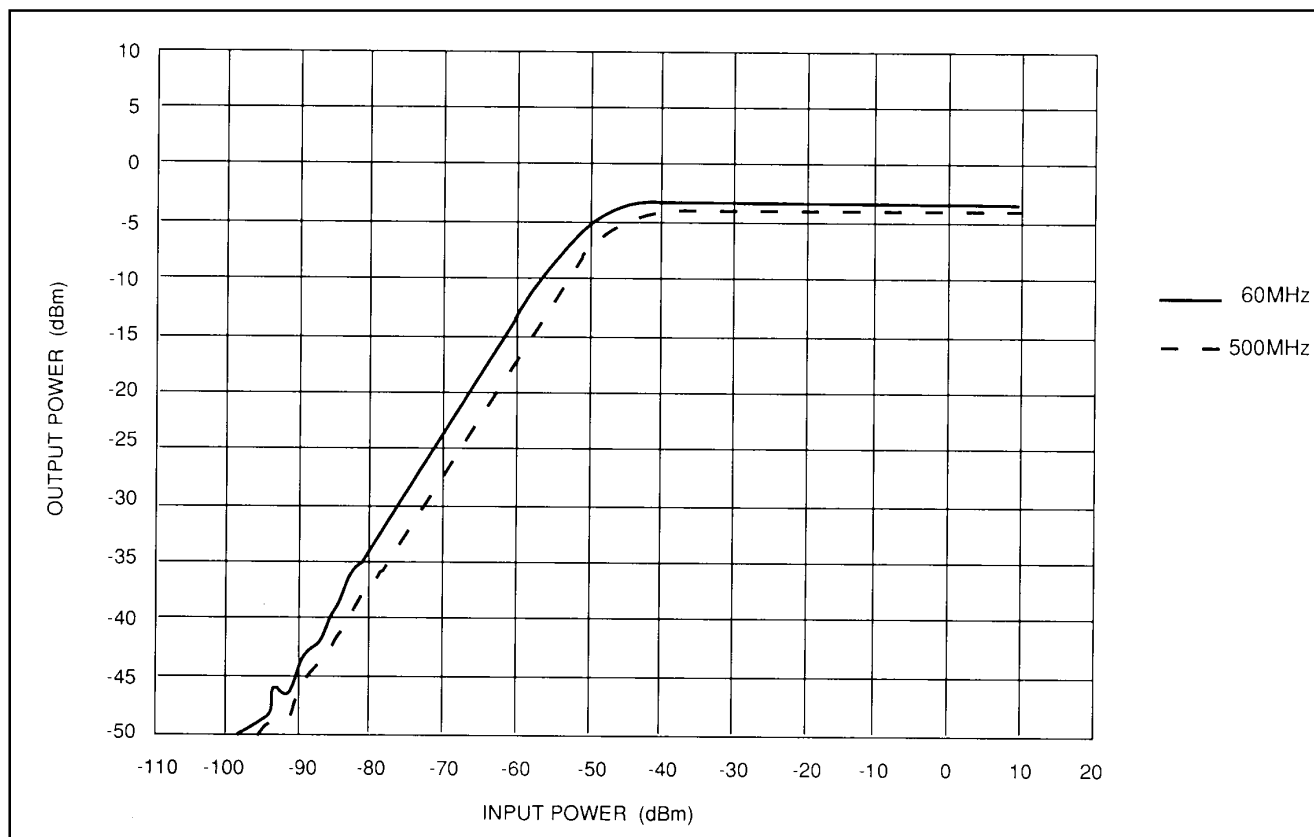

Fig.16 IF limiting characteristics at 60MHz and 500MHz (25°C)

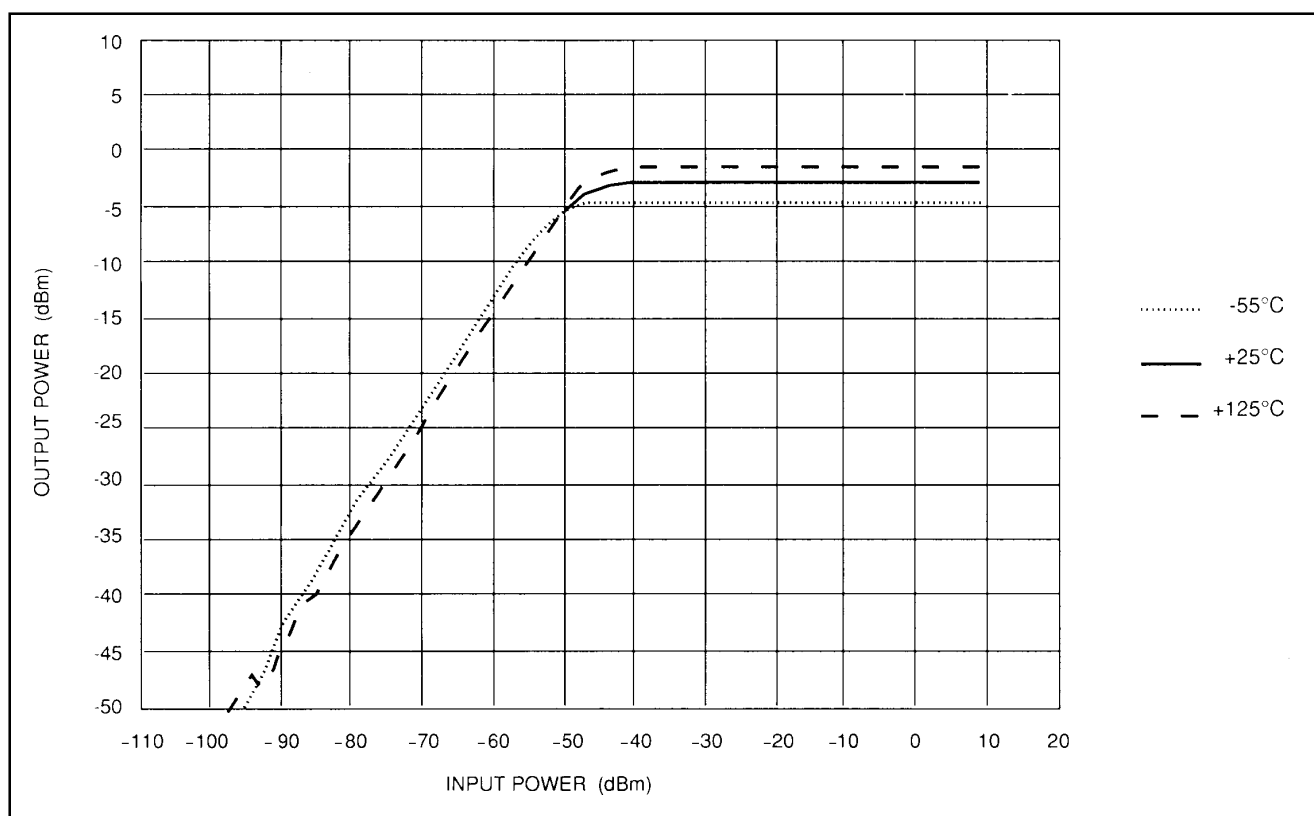

Fig.17 IF limiting characteristic at 60MHz across temperature

SL2524

Typical characteristics for a six stage strip as a low phase shift wideband limiter (Ref. figs 5 & 6)

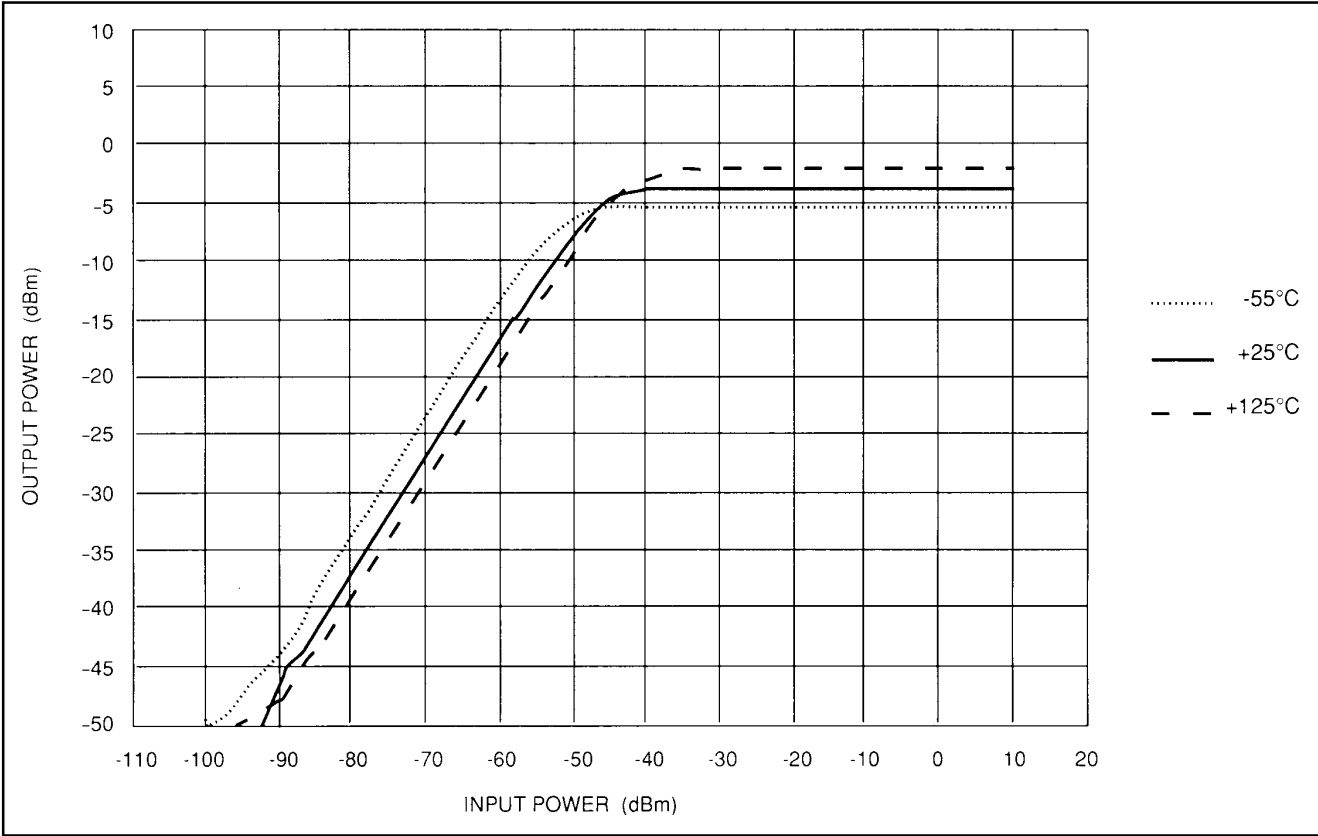

Fig.18 IF limiting characteristic at 500MHz across temperature

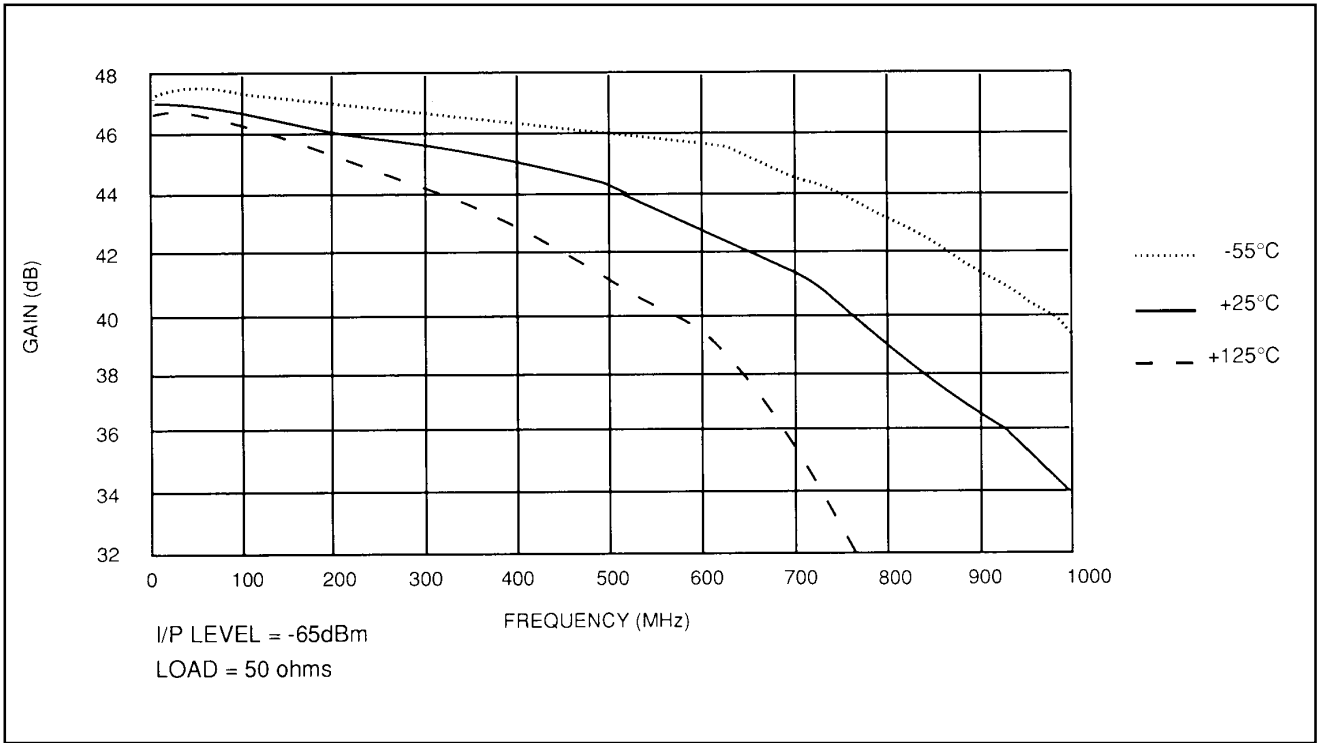

Fig.19 Small signal gain vs frequency across temperature

Typical characteristics for a six stage strip as a low phase shift wideband limiter (Ref. figs 5 & 6)

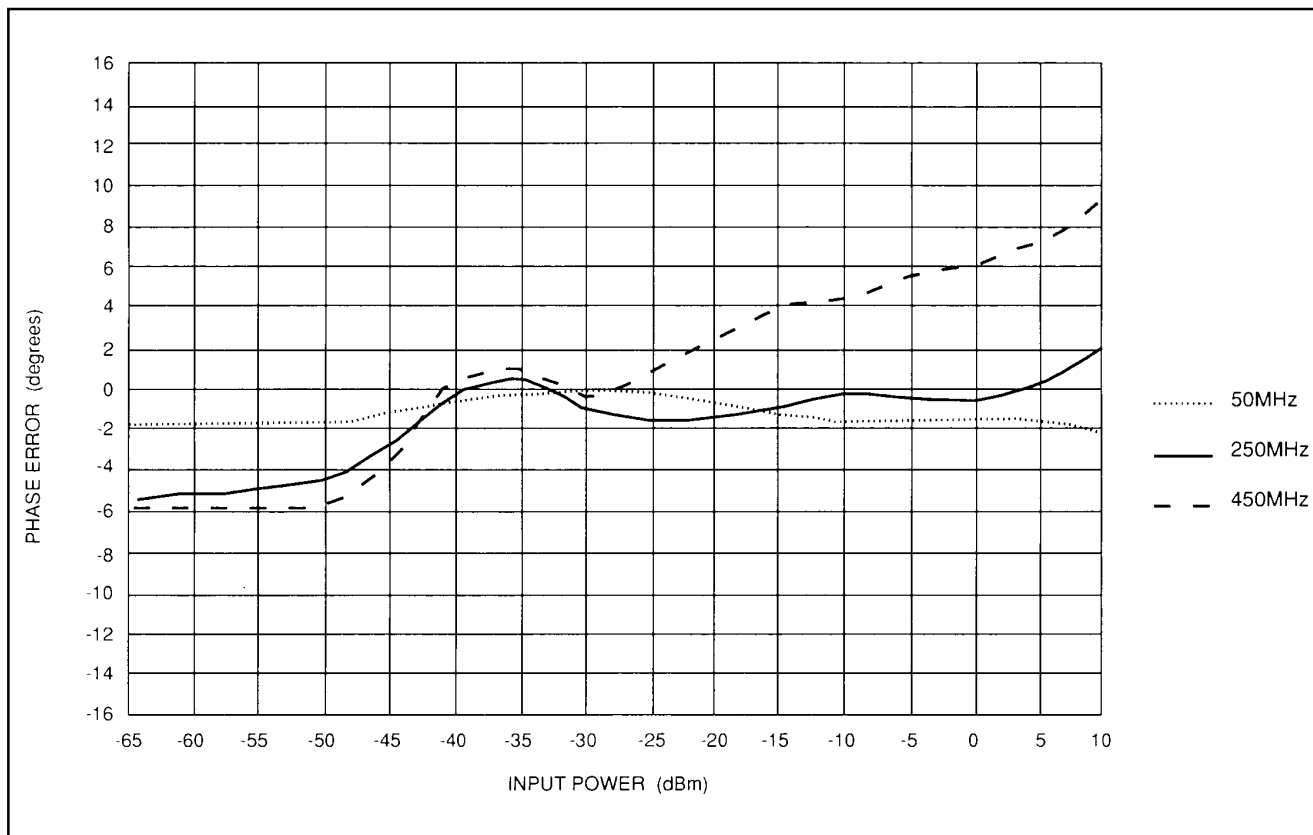

Fig.20 Phase deviation vs CW input level (normalised at -30dBm) at 25°C across input frequency

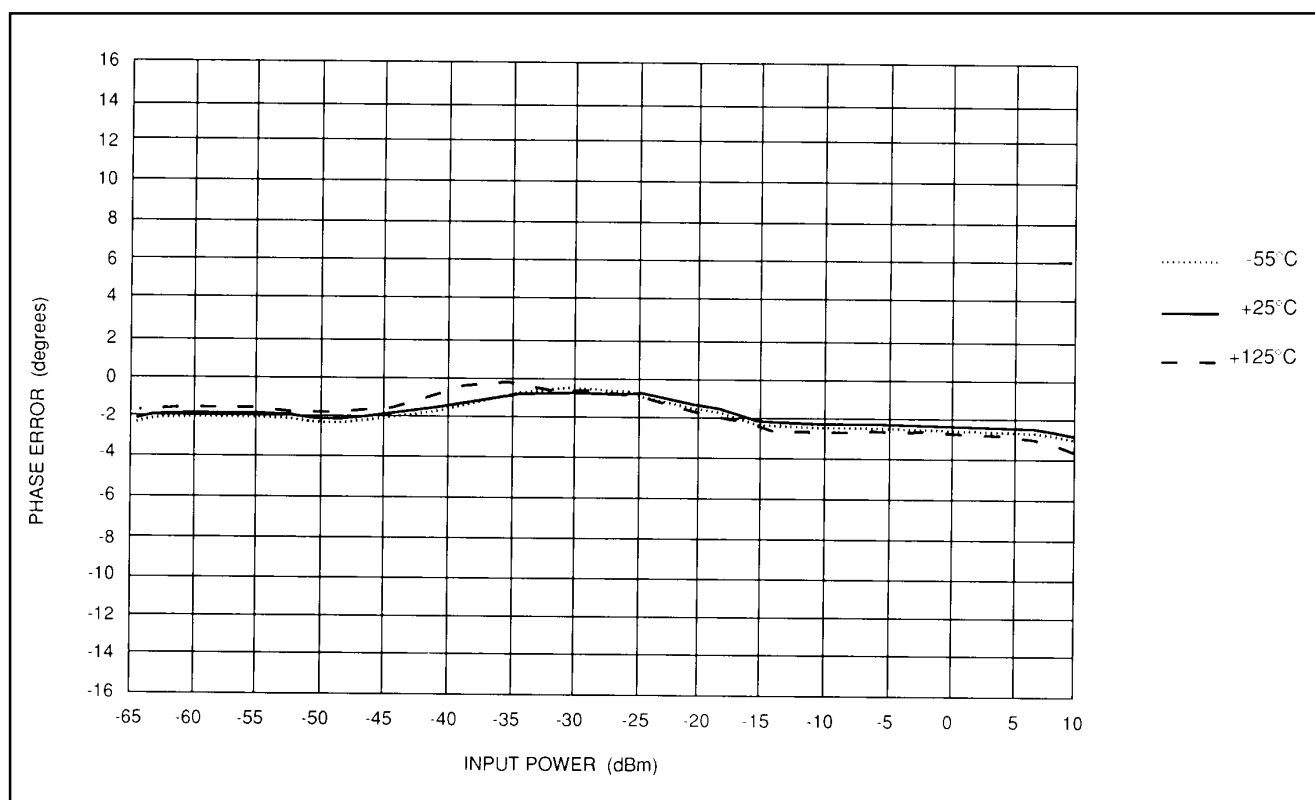

Fig.21 Phase deviation vs CW input level (normalised at -30dBm) at 50MHz across temperature

SL2524

Typical characteristics for a six stage strip as a low phase shift wideband limiter (Ref. figs 5 & 6)

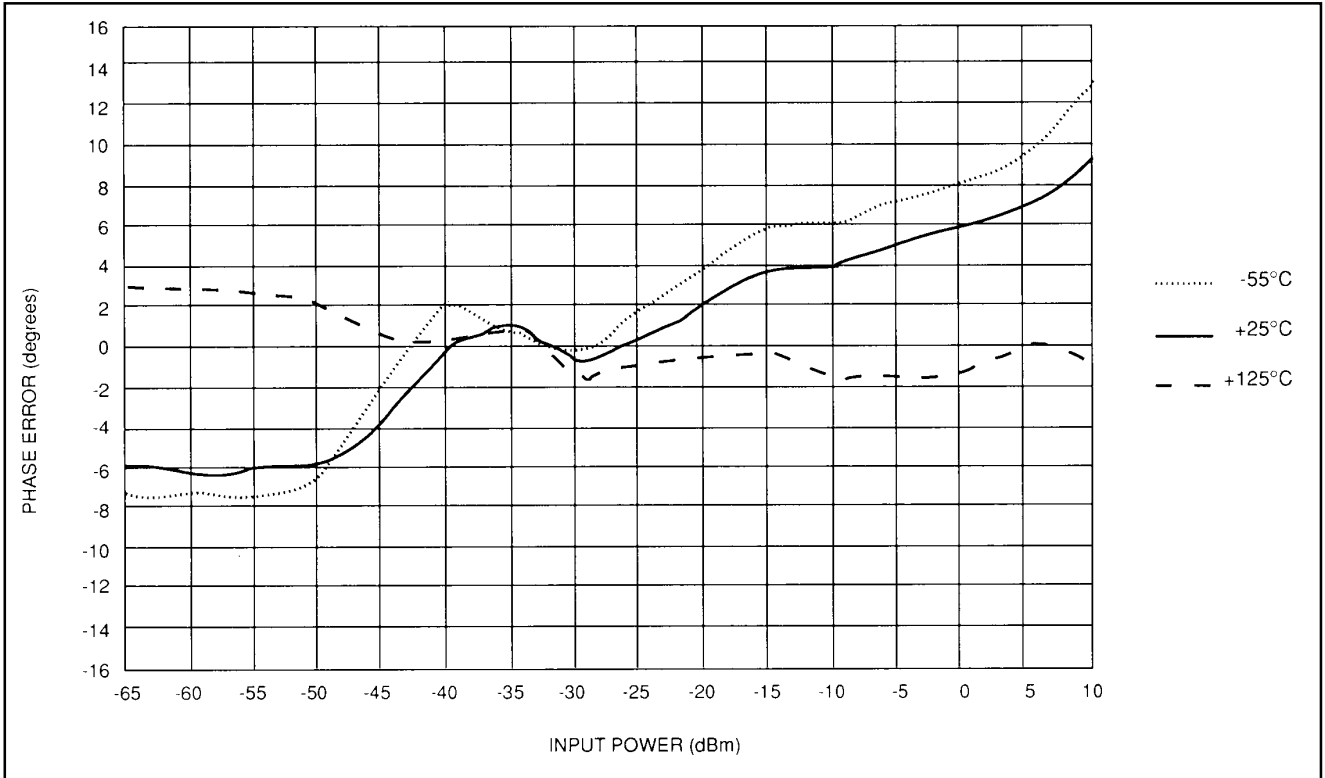

Fig.22 Phase deviation vs CW input level (normalised at -30dBm) at 450MHz across temperature

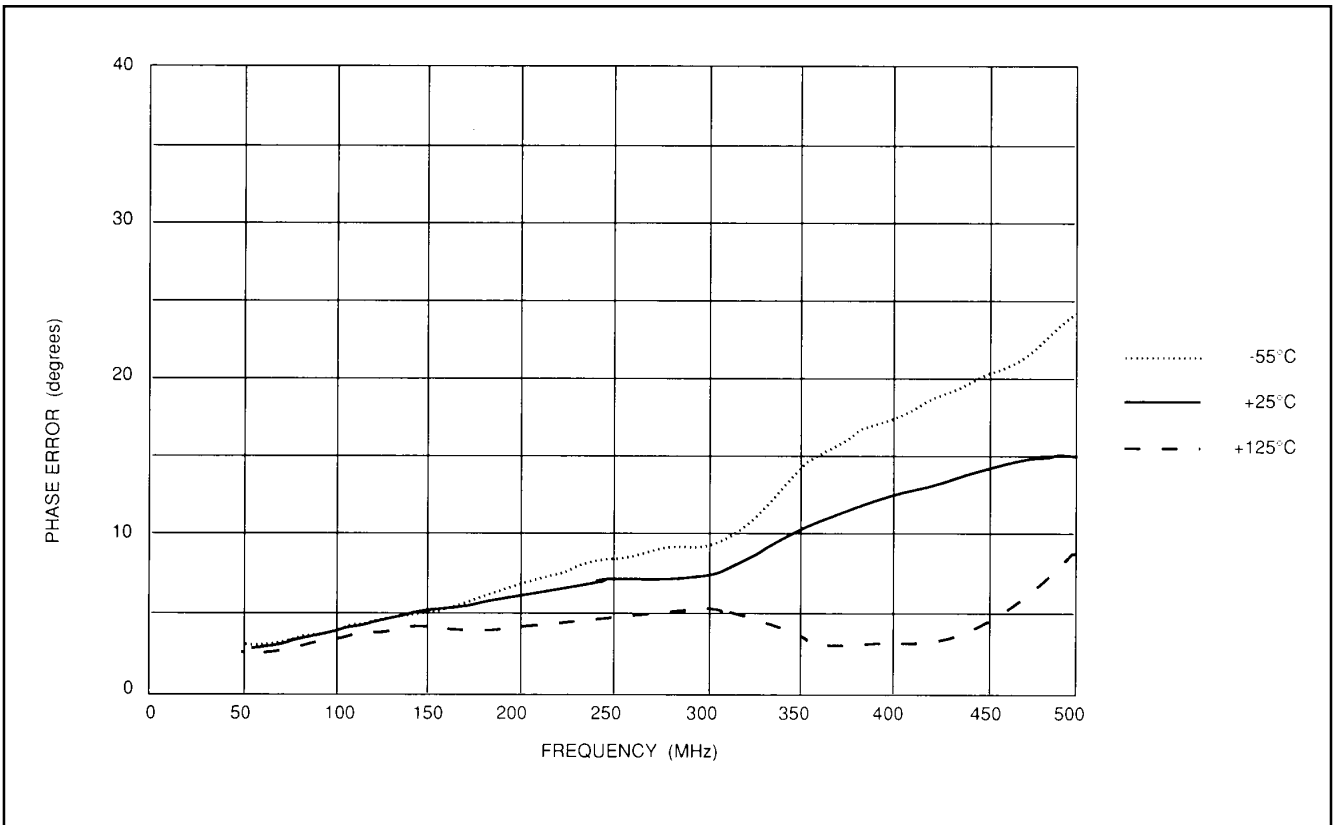
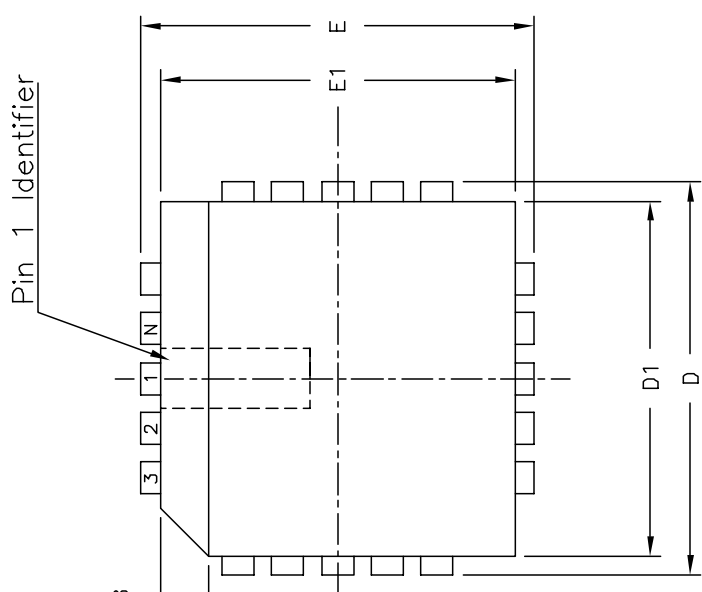
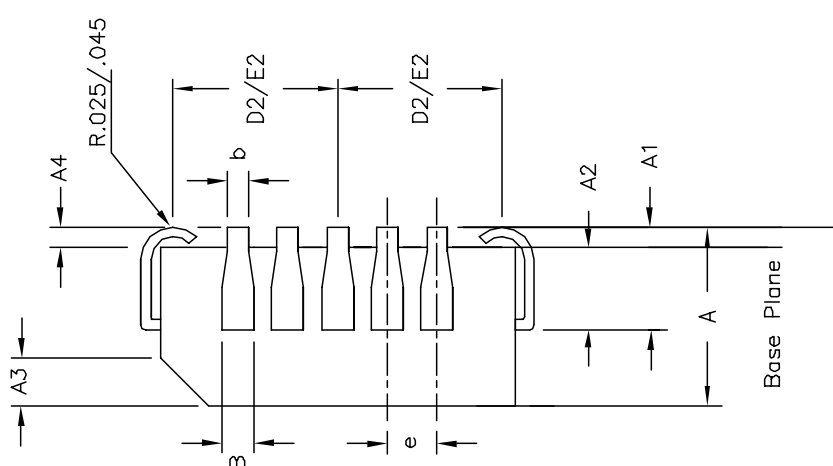

Fig.23 Peak phase deviation over -65dBm → +10dBm CW input level vs CW input frequency. Across temperature



Symbol	Control Dimensions in inches		Altern. Dimensions in millimetres	
	MIN	MAX	MIN	MAX
A	0.165	0.180	4.19	4.57
A1	0.090	0.120	2.29	3.05
A2	0.062	0.083	1.57	2.11
A3	0.042	0.056	1.07	1.42
A4	0.020	—	0.51	—
D	0.385	0.395	9.78	10.03
D1	0.350	0.356	8.89	9.04
D2	0.141	0.169	3.58	4.29
E	0.385	0.395	9.78	10.03
E1	0.350	0.356	8.89	9.04
E2	0.141	0.169	3.58	4.29
B	0.026	0.032	0.66	0.81
b	0.013	0.021	0.33	0.53
e	0.050	BSC	1.27	BSC
Pin features				
ND	5			
NE	5			
N	20			
Note	Square			
Conforms to JEDEC MS-018AA Iss. A				

Notes:
 All dimensions and tolerances conform to ANSI Y14.5M-1982
 Dimensions D1 and E1 do not include mould protrusions.
 Allowable mould protrusion is 0.010" per side. Dimensions D1 and E1 include mould protrusion mismatch and are determined at the parting line, that is D1 and E1 are measured at the extreme material condition at the upper or lower parting line.
 Controlling dimensions in Inches.
 "N" is the number of terminals.
 Not To Scale
 Dimension R required for 120° minimum bend.

Title: Package Outline for 20 Lead PLCC	
Drawing Number	GPD00001
ORIGINATING SITE: Swindon	

MITEL SEMICONDUCTOR	
1	2
5958	207468
15AUG94	10SEP99
as an unpublished work the copyright in which vests in Mitel Semiconductor Limited. All rights reserved.	

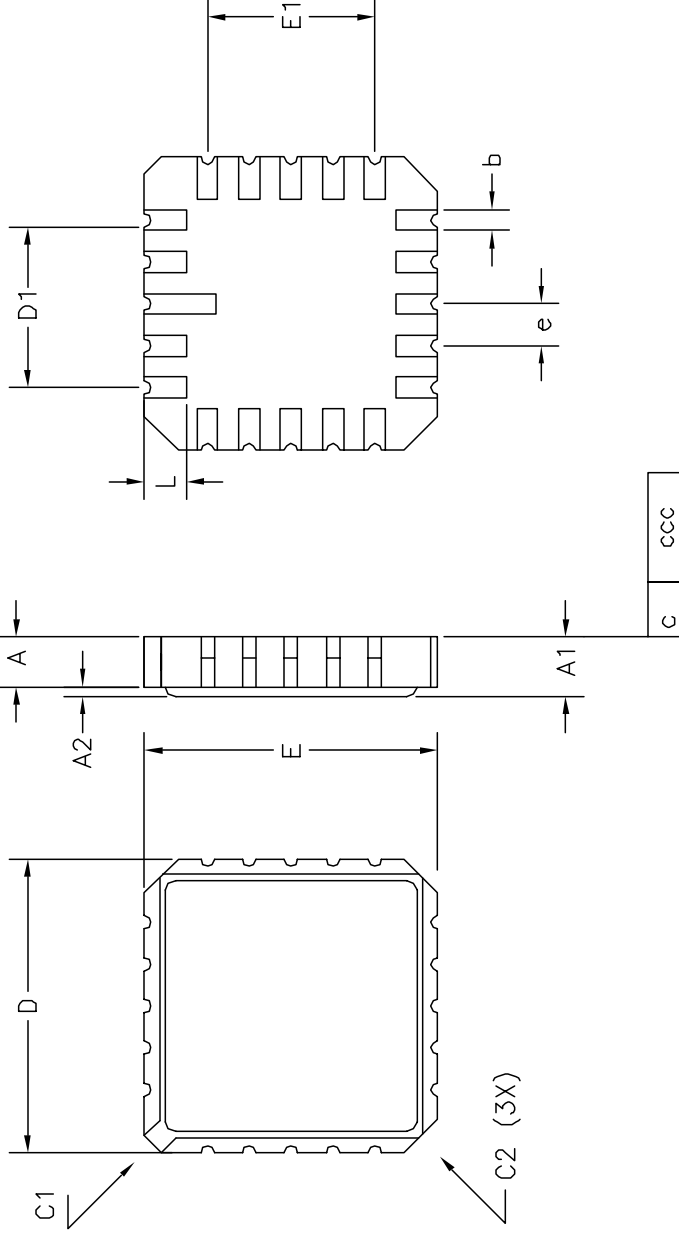

CONTROL DIMENSIONS (inch)			
SYMBOL	MIN.	NOM.	MAX.
A	0.054		0.066
A1	0.064		0.080
A2	0.010		0.014
D	0.342		0.358
D2		0.315REF	
E	0.342		0.358
E2		0.315REF	
e		0.050BSC	
b		0.025	
C1		0.020	
C2		0.040	
L	0.045		0.055
L1	0.077		0.093
R1	0.007		0.011
ccc			.003

Complies with Jeduc MS004-CB
 Supersedes 418/ED/39509/102

MITEL (1998) All rights reserved.

ORIGINATING SITE: Swindon

MITEL SEMICONDUCTOR

Title: Customer Outline Drawing for
 20 Ceramic Leadless Chip Carrier
 (0.35 x 0.35 x 0.08"), 0.05" pitch

Drawing Number

GPD00562



<http://www.mitelsemi.com>

World Headquarters - Canada

Tel: +1 (613) 592 2122

Fax: +1 (613) 592 6909

North America

Tel: +1 (770) 486 0194

Fax: +1 (770) 631 8213

Asia/Pacific

Tel: +65 333 6193

Fax: +65 333 6192

**Europe, Middle East,
and Africa (EMEA)**

Tel: +44 (0) 1793 518528

Fax: +44 (0) 1793 518581

Information relating to products and services furnished herein by Mitel Corporation or its subsidiaries (collectively "Mitel") is believed to be reliable. However, Mitel assumes no liability for errors that may appear in this publication, or for liability otherwise arising from the application or use of any such information, product or service or for any infringement of patents or other intellectual property rights owned by third parties which may result from such application or use. Neither the supply of such information or purchase of product or service conveys any license, either express or implied, under patents or other intellectual property rights owned by Mitel or licensed from third parties by Mitel, whatsoever. Purchasers of products are also hereby notified that the use of product in certain ways or in combination with Mitel, or non-Mitel furnished goods or services may infringe patents or other intellectual property rights owned by Mitel.

This publication is issued to provide information only and (unless agreed by Mitel in writing) may not be used, applied or reproduced for any purpose nor form part of any order or contract nor to be regarded as a representation relating to the products or services concerned. The products, their specifications, services and other information appearing in this publication are subject to change by Mitel without notice. No warranty or guarantee express or implied is made regarding the capability, performance or suitability of any product or service. Information concerning possible methods of use is provided as a guide only and does not constitute any guarantee that such methods of use will be satisfactory in a specific piece of equipment. It is the user's responsibility to fully determine the performance and suitability of any equipment using such information and to ensure that any publication or data used is up to date and has not been superseded. Manufacturing does not necessarily include testing of all functions or parameters. These products are not suitable for use in any medical products whose failure to perform may result in significant injury or death to the user. All products and materials are sold and services provided subject to Mitel's conditions of sale which are available on request.

M Mitel (design) and ST-BUS are registered trademarks of MITEL Corporation

Mitel Semiconductor is an ISO 9001 Registered Company

Copyright 1999 MITEL Corporation

All Rights Reserved

Printed in CANADA

TECHNICAL DOCUMENTATION - NOT FOR RESALE