

SN5406, SN5416, SN7406, SN7416 HEX INVERTER BUFFERS/DRIVERS WITH OPEN-COLLECTOR HIGH-VOLTAGE OUTPUTS

SDLS031A – DECEMBER 1983 – REVISED DECEMBER 2001

- Convert TTL Voltage Levels to MOS Levels
- High Sink-Current Capability
- Input Clamping Diodes Simplify System Design
- Open-Collector Drivers for Indicator Lamps and Relays
- Inputs Fully Compatible With Most TTL Circuits

description

These TTL hex inverter buffers/drivers feature high-voltage open-collector outputs for interfacing with high-level circuits (such as MOS) or for driving high-current loads (such as lamps or relays), and also are characterized for use as inverter buffers for driving TTL inputs. The SN5406 and SN7406 have minimum breakdown voltages of 30 V. The SN5416 and SN7416 have minimum breakdown voltages of 15 V. The maximum sink current is 30 mA for the SN5406 and SN7406, and 40 mA for the SN5416, and 40 mA for the SN7406 and SN7416.

SN5406, SN5416 . . . J OR W PACKAGE
SN7406 . . . D, N, OR NS PACKAGE
SN7416 . . . D OR N PACKAGE

(TOP VIEW)

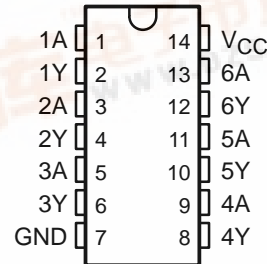

SN5406 . . . FK PACKAGE
(TOP VIEW)

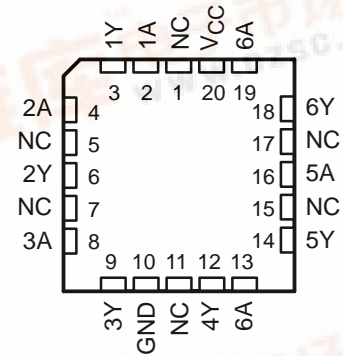

NC – No internal connection

ORDERING INFORMATION

TA	PACKAGE†	ORDERABLE PART NUMBER	TOP-SIDE MARKING	
0°C to 70°C	SOIC – D	Tube	SN7406D	
		Tape and reel	SN7406DR	
		Tube	SN7416D	
		Tape and reel	SN7416DR	
	PDIP – N	Tube	SN7406N	SN7406N
			SN7416N	SN7416N
SOP – NS	Tape and reel	SN7406NSR	SN7406	
–55°C to 125°C	CDIP – J	Tube	SNJ5406J	SNJ5406J
		Tube	SNJ5416J	SNJ5416J
	CDIP – W	Tube	SNJ5406W	SNJ5406W
		Tube	SNJ5416W	SNJ5416W
	LCCC – FK	Tube	SNJ5406FK	SNJ5406FK

† Package drawings, standard packing quantities, thermal data, symbolization, and PCB design guidelines are available at www.ti.com/sc/package.

Please be aware that an important notice concerning availability, standard warranty, and use in critical applications of Texas Instruments semiconductor products and disclaimers thereto appears at the end of this data sheet.



PRODUCTION DATA information is current as of publication date. Products conform to specifications per the terms of Texas Instruments standard warranty. Production processing does not necessarily include testing of all parameters.



Copyright © 2001, Texas Instruments Incorporated
On products compliant to MIL-PRF-38535, all parameters are tested unless otherwise noted. On all other products, production processing does not necessarily include testing of all parameters.

SN5406, SN5416, SN7406, SN7416 HEX INVERTER BUFFERS/DRIVERS WITH OPEN-COLLECTOR HIGH-VOLTAGE OUTPUTS

SDLS031A – DECEMBER 1983 – REVISED DECEMBER 2001

logic diagram (positive logic)

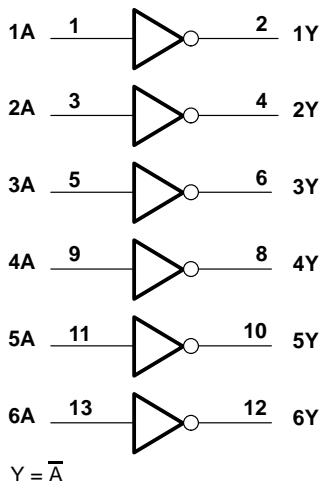

schematic (each buffer/driver)

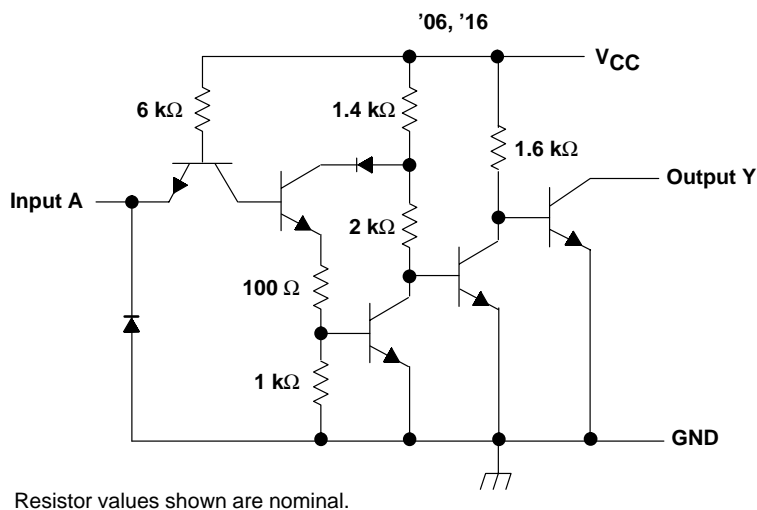

absolute maximum ratings over operating free-air temperature (unless otherwise noted)†

Supply voltage, V_{CC} (see Note 1)	7 V
Input voltage, V_I (see Note 1)	5.5 V
Output voltage, V_O (see Notes 1 and 2): SN5406, SN7406	30 V
SN5416, SN7416	15 V
Package thermal impedance, θ_{JA} (see Note 3): D package	86°C/W
N package	80°C/W
NS package	76°C/W
Storage temperature range, T_{stg}	-65°C to 150°C

† Stresses beyond those listed under “absolute maximum ratings” may cause permanent damage to the device. These are stress ratings only, and functional operation of the device at these or any other conditions beyond those indicated under “recommended operating conditions” is not implied. Exposure to absolute-maximum-rated conditions for extended periods may affect device reliability.

- NOTES:
1. Voltage values are with respect to network ground terminal.
 2. This is the maximum voltage which should be applied to any output when it is in the off state.
 3. The package thermal impedance is calculated in accordance with JESD 51-7.

SN5406, SN5416, SN7406, SN7416
HEX INVERTER BUFFERS/DRIVERS
WITH OPEN-COLLECTOR HIGH-VOLTAGE OUTPUTS
SDLS031A – DECEMBER 1983 – REVISED DECEMBER 2001

recommended operating conditions

	SN5406 SN5416			SN7406 SN7416			UNIT
	MIN	NOM	MAX	MIN	NOM	MAX	
V _{CC} Supply voltage	4.5	5	5.5	4.75	5	5.25	V
V _{IH} High-level input voltage	2			2			V
V _{IL} Low-level input voltage	0.8			0.8			V
V _{OH} High-level output voltage	'06		30	'06		30	V
	'16		15	'16		15	
I _{OL} Low-level output current	30			40			mA
T _A Operating free-air temperature	-55		125	0		70	°C

electrical characteristics over recommended operating free-air temperature range (unless otherwise noted)

PARAMETER	TEST CONDITIONS†	SN5406 SN5416			SN7406 SN7416			UNIT
		MIN	TYP‡	MAX	MIN	TYP‡	MAX	
V _{IK}	V _{CC} = MIN, I _I = -12 mA	-1.5			-1.5			V
I _{OH}	V _{CC} = MIN, V _{IL} = 0.8 V, V _{OH} = §	0.25			0.25			mA
V _{OL}	V _{CC} = MIN, V _{IH} = 2 V, I _{OL} = ¶	0.4			0.4			V
		0.7			0.7			
I _I	V _{CC} = MAX, V _I = 5.5 V	1			1			mA
I _{IH}	V _{CC} = MAX, V _{IH} = 2.4 V	40			40			µA
I _{IL}	V _{CC} = MAX, V _{IL} = 0.4 V	-1.6			-1.6			mA
I _{CCH}	V _{CC} = MAX	30	48	30	48	mA		
I _{CCL}	V _{CC} = MAX	32	51	32	51	mA		

† For conditions shown as MIN or MAX, use the appropriate value specified under recommended operating conditions.

‡ All typical values are at V_{CC} = 5 V, T_A = 25°C.

§ V_{OH} = 30 V for '06 and 15 V for '16.

¶ I_{OL} = 30 mA for SN54' and 40 mA for SN74'.

switching characteristics, V_{CC} = 5 V, T_A = 25°C (see Figure 1)

PARAMETER	FROM (INPUT)	TO (OUTPUT)	TEST CONDITIONS	MIN	TYP	MAX	UNIT
t _{PLH}	A	Y	R _L = 110 Ω, C _L = 15 pF	10		15	ns
t _{PHL}				15		23	

SN5406, SN5416, SN7406, SN7416
HEX INVERTER BUFFERS/DRIVERS
WITH OPEN-COLLECTOR HIGH-VOLTAGE OUTPUTS
 SDLS031A – DECEMBER 1983 – REVISED DECEMBER 2001

PARAMETER MEASUREMENT INFORMATION

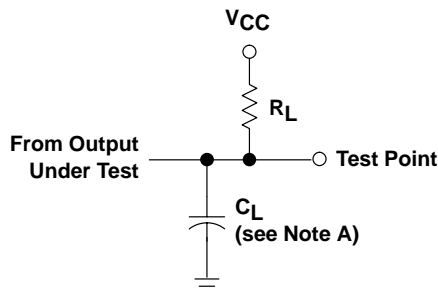

LOAD CIRCUIT

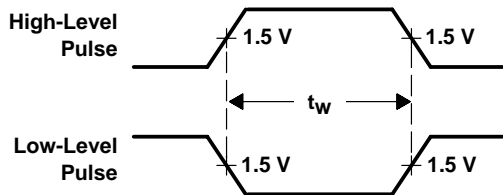

VOLTAGE WAVEFORMS
PULSE WIDTHS

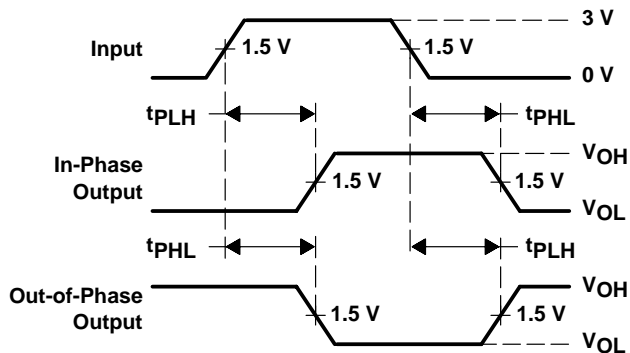

VOLTAGE WAVEFORMS
PROPAGATION DELAY TIMES

- NOTES: A. C_L includes probe and jig capacitance.
 B. In the examples above, the phase relationships between inputs and outputs have been chosen arbitrarily.
 C. All input pulses are supplied by generators having the following characteristics: $PRR \leq 1 \text{ MHz}$, $Z_O = 50 \Omega$, $t_r \leq 7 \text{ ns}$, $t_f \leq 7 \text{ ns}$.
 D. The outputs are measured one at a time with one input transition per measurement.

Figure 1. Load Circuit and Voltage Waveforms

PACKAGING INFORMATION

Orderable Device	Status ⁽¹⁾	Package Type	Package Drawing	Pins	Package Qty	Eco Plan ⁽²⁾	Lead/Ball Finish	MSL Peak Temp ⁽³⁾
JM38510/00801BCA	ACTIVE	CDIP	J	14	1	None	Call TI	Level-NC-NC-NC
JM38510/00801BDA	ACTIVE	CFP	W	14	1	None	Call TI	Level-NC-NC-NC
SN5406J	ACTIVE	CDIP	J	14	1	None	Call TI	Level-NC-NC-NC
SN5416J	ACTIVE	CDIP	J	14	1	None	Call TI	Level-NC-NC-NC
SN7406D	ACTIVE	SOIC	D	14	50	Pb-Free (RoHS)	CU NIPDAU	Level-2-260C-1 YEAR/ Level-1-235C-UNLIM
SN7406DR	ACTIVE	SOIC	D	14	2500	Pb-Free (RoHS)	CU NIPDAU	Level-2-260C-1 YEAR/ Level-1-235C-UNLIM
SN7406J	OBSOLETE	CDIP	J	14		None	Call TI	Call TI
SN7406N	ACTIVE	PDIP	N	14	25	Pb-Free (RoHS)	CU NIPDAU	Level-NC-NC-NC
SN7406N3	OBSOLETE	PDIP	N	14		None	Call TI	Call TI
SN7406NSR	ACTIVE	SO	NS	14	2000	Pb-Free (RoHS)	CU NIPDAU	Level-2-260C-1 YEAR/ Level-1-235C-UNLIM
SN7416D	ACTIVE	SOIC	D	14	50	Pb-Free (RoHS)	CU NIPDAU	Level-2-260C-1 YEAR/ Level-1-235C-UNLIM
SN7416DR	ACTIVE	SOIC	D	14	2500	Pb-Free (RoHS)	CU NIPDAU	Level-2-260C-1 YEAR/ Level-1-235C-UNLIM
SN7416N	ACTIVE	PDIP	N	14	25	Pb-Free (RoHS)	CU NIPDAU	Level-NC-NC-NC
SN7416N3	OBSOLETE	PDIP	N	14		None	Call TI	Call TI
SN7416NSR	ACTIVE	SO	NS	14	2000	Pb-Free (RoHS)	CU NIPDAU	Level-2-260C-1 YEAR/ Level-1-235C-UNLIM
SNJ5406FK	ACTIVE	LCCC	FK	20	1	None	Call TI	Level-NC-NC-NC
SNJ5406J	ACTIVE	CDIP	J	14	1	None	Call TI	Level-NC-NC-NC
SNJ5406W	ACTIVE	CFP	W	14	1	None	Call TI	Level-NC-NC-NC
SNJ5416J	ACTIVE	CDIP	J	14	1	None	Call TI	Level-NC-NC-NC
SNJ5416W	ACTIVE	CFP	W	14	1	None	Call TI	Level-NC-NC-NC

⁽¹⁾ The marketing status values are defined as follows:

ACTIVE: Product device recommended for new designs.

LIFEBUY: TI has announced that the device will be discontinued, and a lifetime-buy period is in effect.

NRND: Not recommended for new designs. Device is in production to support existing customers, but TI does not recommend using this part in a new design.

PREVIEW: Device has been announced but is not in production. Samples may or may not be available.

OBSOLETE: TI has discontinued the production of the device.

⁽²⁾ Eco Plan - May not be currently available - please check <http://www.ti.com/productcontent> for the latest availability information and additional product content details.

None: Not yet available Lead (Pb-Free).

Pb-Free (RoHS): TI's terms "Lead-Free" or "Pb-Free" mean semiconductor products that are compatible with the current RoHS requirements for all 6 substances, including the requirement that lead not exceed 0.1% by weight in homogeneous materials. Where designed to be soldered at high temperatures, TI Pb-Free products are suitable for use in specified lead-free processes.

Green (RoHS & no Sb/Br): TI defines "Green" to mean "Pb-Free" and in addition, uses package materials that do not contain halogens, including bromine (Br) or antimony (Sb) above 0.1% of total product weight.

⁽³⁾ MSL, Peak Temp. -- The Moisture Sensitivity Level rating according to the JEDEC industry standard classifications, and peak solder temperature.

Important Information and Disclaimer: The information provided on this page represents TI's knowledge and belief as of the date that it is

provided. TI bases its knowledge and belief on information provided by third parties, and makes no representation or warranty as to the accuracy of such information. Efforts are underway to better integrate information from third parties. TI has taken and continues to take reasonable steps to provide representative and accurate information but may not have conducted destructive testing or chemical analysis on incoming materials and chemicals. TI and TI suppliers consider certain information to be proprietary, and thus CAS numbers and other limited information may not be available for release.

In no event shall TI's liability arising out of such information exceed the total purchase price of the TI part(s) at issue in this document sold by TI to Customer on an annual basis.

IMPORTANT NOTICE

Texas Instruments Incorporated and its subsidiaries (TI) reserve the right to make corrections, modifications, enhancements, improvements, and other changes to its products and services at any time and to discontinue any product or service without notice. Customers should obtain the latest relevant information before placing orders and should verify that such information is current and complete. All products are sold subject to TI's terms and conditions of sale supplied at the time of order acknowledgment.

TI warrants performance of its hardware products to the specifications applicable at the time of sale in accordance with TI's standard warranty. Testing and other quality control techniques are used to the extent TI deems necessary to support this warranty. Except where mandated by government requirements, testing of all parameters of each product is not necessarily performed.

TI assumes no liability for applications assistance or customer product design. Customers are responsible for their products and applications using TI components. To minimize the risks associated with customer products and applications, customers should provide adequate design and operating safeguards.

TI does not warrant or represent that any license, either express or implied, is granted under any TI patent right, copyright, mask work right, or other TI intellectual property right relating to any combination, machine, or process in which TI products or services are used. Information published by TI regarding third-party products or services does not constitute a license from TI to use such products or services or a warranty or endorsement thereof. Use of such information may require a license from a third party under the patents or other intellectual property of the third party, or a license from TI under the patents or other intellectual property of TI.

Reproduction of information in TI data books or data sheets is permissible only if reproduction is without alteration and is accompanied by all associated warranties, conditions, limitations, and notices. Reproduction of this information with alteration is an unfair and deceptive business practice. TI is not responsible or liable for such altered documentation.

Resale of TI products or services with statements different from or beyond the parameters stated by TI for that product or service voids all express and any implied warranties for the associated TI product or service and is an unfair and deceptive business practice. TI is not responsible or liable for any such statements.

Following are URLs where you can obtain information on other Texas Instruments products and application solutions:

Products		Applications	
Amplifiers	amplifier.ti.com	Audio	www.ti.com/audio
Data Converters	dataconverter.ti.com	Automotive	www.ti.com/automotive
DSP	dsp.ti.com	Broadband	www.ti.com/broadband
Interface	interface.ti.com	Digital Control	www.ti.com/digitalcontrol
Logic	logic.ti.com	Military	www.ti.com/military
Power Mgmt	power.ti.com	Optical Networking	www.ti.com/opticalnetwork
Microcontrollers	microcontroller.ti.com	Security	www.ti.com/security
		Telephony	www.ti.com/telephony
		Video & Imaging	www.ti.com/video
		Wireless	www.ti.com/wireless

Mailing Address: Texas Instruments
Post Office Box 655303 Dallas, Texas 75265