

THIS COPY IS PROVIDED ON A RESTRICTED BASIS AND IS NOT TO BE USED IN ANY WAY DETRIMENTAL TO THE INTERESTS OF PANDUIT CORP.

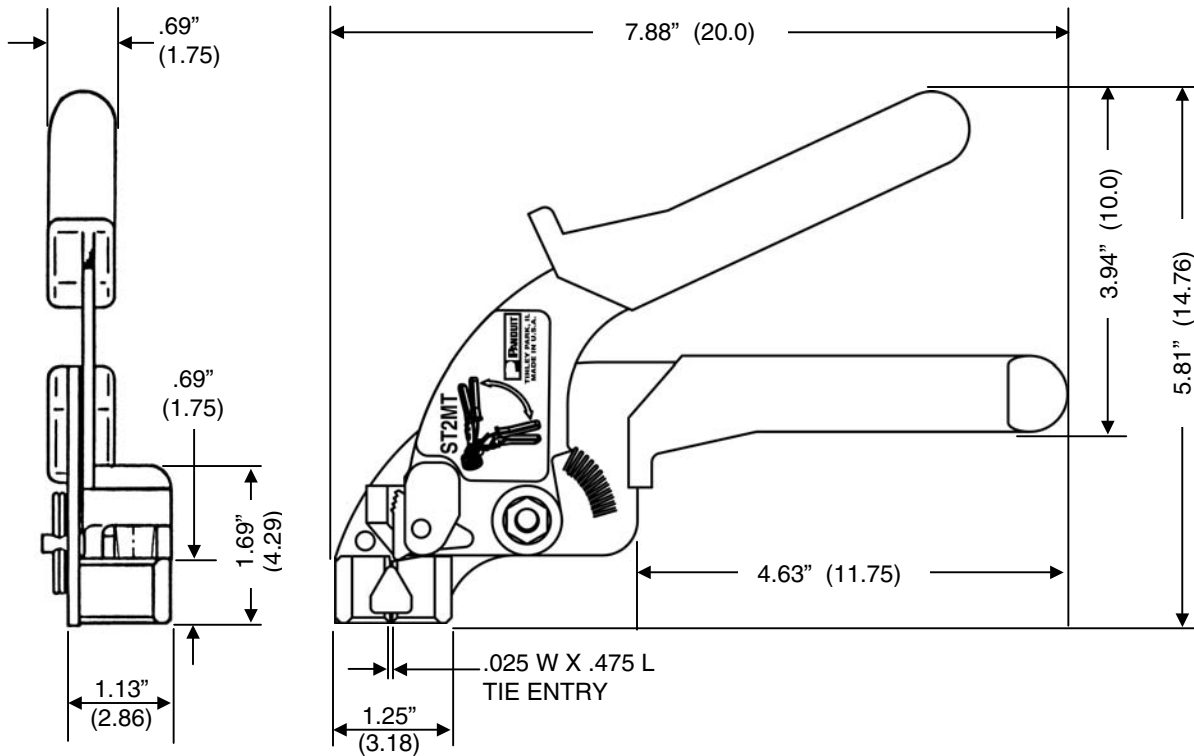

NOTES, UNLESS OTHERWISE SPECIFIED:
 PANDUIT TOOL NUMBER ST2MT IS USED TO INSTALL ALL STANDARD, LIGHT-HEAVY, HEAVY AND EXTRA-HEAVY CROSS SECTION PAN-STEEL TYPE MLT TIES, TYPE MLTC COATED TIES AND TYPE MLTDH DOUBLE WRAPPED TIES.

THIS TOOL'S FEATURES INCLUDE:

- Cable tie side entry for immediate positioning of tie and tool
- One hand operation – lightweight
- Installer controlled tension
- Cut-off capability with the twist of the wrist
- Easy removal of excess tie

CABLE TIE CODE:

MLT = Metal Locking Tie

MLTC = Nylon 11 Coated Stainless Steel Tie

MLTDH = Double Wrapped Stainless Steel Cable Tie

TOOL WEIGHT = 16 OZ. (454 GRAMS)

DIMENSIONS SHOWN IN PARENTHESIS ARE

F:/RVUSERS/ENGDOCS/CUSTDWGS/TB24535A01_02 ST2MT.doc

								PANDUIT CORP. TINLEY PARK, ILLINOIS	
								ST2MT CUSTOMER DRAWING	
								UNLESS OTHERWISE SPECIFIED, DIMENSIONAL TOLERANCES ARE:	
								(.x) ± --- (.xxx) ± --- (.xx) ± --- ANGLES ± ---	
								UNLESS OTHERWISE SPECIFIED, ALL DIMENSIONS ARE GIVEN IN INCHES, THIRD ANGLE PROJECTION.	
02	10-19-06	BLR	ABJ	GRAPHIC UPDATE ADD EH TIE USAGE	4214	--	LAH	DRAWN BY: WDE	MATL: -----
01	8-12-04	BLR	ABJ	REDRWN; CHNG WEIGHT TO OZ.	4141	--	DLWE	DATE: 1-17-02	SCALE NONE
00	1-17-02	WDE	ABJ	RELEASED	3919	--	LAH	CHK'D: ABJ	DRAWING NO. TB24535A01
REV	DATE	BY	CHK'D	DESCRIPTION	ECN	-R	CUST	SUP	DWG A SIZE