



STV0056A

SATELLITE SOUND AND VIDEO PROCESSOR

ADVANCE DATA

SOUND

- TWO INDEPENDENT SOUND DEMODULATORS
- PLL DEMODULATION WITH 5-10MHz FREQUENCY SYNTHESIS
- PROGRAMMABLE FM DEMODULATOR BANDWIDTH ACCOMODATING FM DEVIATIONS FROM $\pm 30\text{kHz}$ TILL $\pm 400\text{kHz}$
- PROGRAMMABLE 50/75 μs , J17 OR NO DE-EMPHASIS
- WEGENER PANDA SYSTEM
- TWO AUXILIARY AUDIO INPUTS AND OUTPUTS
- GAIN CONTROLLED AND MUTEABLE AUDIO OUTPUTS
- HIGH IMPEDANCE MODE AUDIO OUTPUTS FOR TWIN TUNER APPLICATIONS

VIDEO

- COMPOSITE VIDEO 6-bit 0 to 12.7dB GAIN CONTROL
- COMPOSITE VIDEO SELECTABLE INVERTER
- TWO SELECTABLE VIDEO DE-EMPHASIS NETWORKS
- 6 x 3 VIDEO MATRIX
- BLACK LEVEL ADJUSTABLE OUTPUT FOR ON-BOARD VIDEOCRYPT DECODER
- HIGH IMPEDANCE MODE VIDEO OUTPUTS FOR TWIN TUNER APPLICATIONS

MISCELLANEOUS

- 22kHz TONE GENERATION FOR LNB CONTROL
- I²C BUS CONTROL
CHIP ADDRESSES = 06_{HEX} OR 46_{HEX}
- LOW POWER STAND-BY MODE WITH ACTIVE AUDIO AND VIDEO MATRIXES

DESCRIPTION

The STV0056A BICMOS integrated circuit realizes all the necessary signal processing from the tuner to the Audio/Video input and output connectors regardless the satellite system.



PIN CONNECTIONS

FC R	1	56	A GND R
PK IN R	2	55	FC L
LEVEL R	3	54	PK IN L
S1 VID RTN	4	53	LEVEL L
S3 VID RTN	5	52	PK OUT L
VOL R	6	51	PK OUT R
S3 VID OUT	7	50	I _{REF}
S1 VID OUT	8	49	CPUMP R
S2 VID OUT	9	48	U75 R
VOL L	10	47	DET R
S2 VID RTN	11	46	AMPLK R
S2 OUT L	12	45	A 12V
CLAMP IN	13	44	V _{REF}
S2 OUT R	14	43	A GND L
UNCL DEEM	15	42	AGC R
VIDEEM2/22kHz	16	41	AMPLK L
V 12V	17	40	U75 L
VIDEEM1	18	39	DET L
V GND	19	38	CPUMP L
B-BAND IN	20	37	GND 5V
S2 RTN L	21	36	V _{DD} 5V
S2 RTN R	22	35	XTL
FM IN	23	34	J17 L
S3 RTN L	24	33	J17 R
S3 RTN R	25	32	HA
AGC L	26	31	SDA
S3 OUT L	27	30	SCL
S3 OUT R	28	29	I/O/22kHz

0056A-01.EPS



STV0056A

PIN ASSIGNMENT

Pin Number	Name	Function
1	FC R	Audio Roll-off Right
2	PK IN R	Noise Reduction Peak Detector Input Right
3	LEVEL R	Noise Reduction Level Right
4	S1 VID RTN	TV-Scart 1 Video Return
5	S3 VID RTN	Decoder-Scart Video Return
6	VOL R	Volume Controlled Audio Out Right
7	S3 VID OUT	Decoder-Scart Video Output
8	S1 VID OUT	TV-Scart 1 Video Output
9	S2 VID OUT	VCR-Scart 2 Video Output
10	VOL L	Volume Controlled Audio Out Left
11	S2 VID RTN	VCR-Scart 2 Video Return
12	S2 OUT L	Fixed Level Audio Output Left (to VCR)
13	CLAMP IN	Sync-Tip Clamp Input
14	S2 OUT R	Fixed Level Audio Output Right (to VCR)
15	UNCL DEEM	Unclamped Deemphasized Video Output
16	VIDEEM2/22kHz	Video Deemphasis 2 or 22kHz Output
17	V 12V	Video 12V Supply
18	VIDEEM1	Video Deemphasis 1
19	V GND	Video Ground
20	B-BAND IN	Base Band Input
21	S2 RTN L	Auxiliary Audio Return Left (from VCR)
22	S2 RTN R	Auxiliary Audio Return Right (from VCR)
23	FM IN	FM Demodulator Input
24	S3 RTN L	Auxiliary Audio Return Left (from decoder)
25	S3 RTN R	Auxiliary Audio Return Right (from decoder)
26	AGC L	AGC Peak Detector Capacitor Left
27	S3 OUT L	Auxiliary Audio Output L (to decoder)
28	S3 OUT R	Auxiliary Audio Output R (to decoder)
29	I/O/22kHz	Digital Input/Output or 22kHz Output
30	SCL	I ² C Bus Clock
31	SDA	I ² C Bus Data
32	HA	Hardware Address
33	J17 R	J17 Deemphasis Time Constant Right
34	J17 L	J17 Deemphasis Time Constant Left
35	XTL	4/8MHz Quartz Crystal or Clock Input
36	V _{DD} 5V	Digital 5V Power Supply
37	GND 5V	Digital Power Ground
38	CPUMP L	FM PLL Charge Pump Capacitor Left
39	DET L	FM PLL Filter Left
40	U75 L	Deemphasis Time Constant Left
41	AMPLK L	Amplitude Detector Capacitor Left
42	AGC R	AGC Peak Detector Capacitor Right
43	A GND L	Audio Ground
44	V _{REF}	2.4V Reference

0056A-01.TBL

PIN ASSIGNMENT (continued)

Pin Number	Name	Function
45	A 12V	Audio 12V Supply
46	AMPLK R	Amplitude Detector Capacitor Left
47	DET R	FM PLL Filter Right
48	U75 R	Deemphasis Time Constant Right
49	CPUMP R	FM PLL Charge Pump Capacitor Right
50	I _{REF}	Current Reference Resistor
51	PK OUT R	Noise Reduction Peak Detector Output Right
52	PK OUT L	Noise Reduction Peak Detector Output Left
53	LEVEL L	Noise Reduction Level Left
54	PK IN L	Noise Reduction Peak Detector Input
55	FC L	Audio Roll-off Left
56	A GND R	Audio Ground

0056A-01.TBL

PIN DESCRIPTION**SOUND DETECTION
FMIN**

This is the input to the two FM demodulators. It feeds two AGC amplifiers with a bandwidth of at least 5-10MHz. There is one amplifier for each channel both with the same input. The AGC amplifiers have a 0dB to +40dB range.

$Z_{IN} = 5k\Omega$, Min input = 2mV_{PP} per subcarrier.
Max input = 500mV_{PP} (max when all inputs are added together, when their phases coincide).

AGC L, AGC R

AGC amplifiers peak detector capacitor connections. The output current has an attack/decay ratio of 1:32. That is the ramp up current is approximately 5 μ A and decay current is approximately 160 μ A. 11V gives maximum gain. These pins are also driven by a circuit monitoring the voltage on AMPLK L and AMPLK R respectively.

AMPLK L, AMPLK R

The outputs of amplitude detectors LEFT and RIGHT. Each requires a capacitor and a resistor to GND. The voltage across this is used to decide whether there is a signal being received by the FM detector. The level detector output drives a bit in the detector I²C bus control block.

AMPLK L and AMPLK R drive also respectively AGC L and AGC R. For instance when the voltage on AMPLK L is > (V_{REF} + 1 V_{BE}) it sinks current to V_{REF} from pin AGCL to reduce the AGC gain.

DET L, DET R

Respectively the outputs of the FM phase detector left and right.

This is for the connection of an external loop filter for the PLL. The output is a push-pull current source.

CPUMP L, CPUMP R

The output from the frequency synthesizer is a push-pull current source which requires a capacitor to ground to derive a voltage to pull the VCO to the target frequency. The output is $\pm 100\mu$ A to achieve lock and $\pm 2\mu$ A during lock to provide a tracking time constant of approximately 10Hz.

V_{REF}

This is the audio processor voltage reference used through out the FM/audio section of the chip. As such it is essential that it is well decoupled to ground to reduce as far as possible the risk of crosstalk and noise injection. This voltage is derived directly from the bandgap reference of 2.4V.

The V_{REF} output can sink up to 500 μ A in normal operation and 100 μ A when in stand-by.

I_{REF}

This is a buffered V_{REF} output to an off-chip resistor to produce an accurate current reference, within the chip, for the biasing of amplifiers with current outputs into filters. It is also required for the Noise reduction circuit to provide accurate roll-off frequencies. This pin should not be decoupled as it would inject current noise. The target current is 50 μ A $\pm 2\%$ thus a 47.5k Ω $\pm 1\%$ is required.

PIN DESCRIPTION (continued)**A 12V**

Double bonded main power pin for the audio/FM section of the chip. The two bond connections are to the ESD and to power the circuit and on chip regulators/references.

A GND L

This ground pin is double bonded :

- 1) to channel LEFT : RF section & VCO,
- 2) to both AGC amplifiers, channel LEFT and RIGHT audio filter section.

A GND R

This ground pin is double bonded :

- 1) to the volume control, noise reduction system, ESD + MUX + V_{REF}
- 2) to channel right : RF section & VCO

**BASEBAND AUDIO PROCESSING
PK OUT L, PK OUT R, PK OUT**

The noise reduction control loop peak detector output requires a capacitor to ground from this pin, and a resistor to V_{REF} pin to give some accurate decay time constant. An on chip 5k Ω \pm 25 % resistor and external capacitor give the attack time.

PK IN L, PK IN R or PK IN

Each of these pins is an input to a control loop peak detector and is connected to the output of the offchip control loop band pass filter.

LEVEL L, LEVEL R

Respectively the audio left and right signals of the FM demodulators are output to level L and level R pins through an input follower buffer. The off-chip filters driven by these pins must include AC coupling to the next stage (PK IN L and PK IN R pins respectively).

FC L, FC R

The variable bandwidth transconductance amplifier has a current output which is variable depending on the input signal amplitude as defined by the control loop of the noise reduction. The output current is then dumped into an off-chip capacitor which together with the accurate current reference define the min/max rolloff frequencies. A resistor in

series with a capacitor is connected to ground from these two pins.

J17 L, J17 R

The external J17 de-emphasis networks for channels left and right. The amplifier for this filter is voltage input, current output. Output with \pm 500mV input will be \pm 55 μ A.

To perform J17 de-emphasis with the STV0042, an external circuit is required.

U75 L, U75 R

External deemphasis networks for channels left and right. For each channel a capacitor and resistor in parallel of 75 μ s time constant are connected between here and V_{REF} to provide 75 μ s de-emphasis. Internally selectable is an internal resistor that can be programmed to be added in parallel thereby converting the network to approx 50 μ s de-emphasis (see control block map). The value of the internal resistors is 54k Ω \pm 30 %. The amplifier for this filter is voltage input, current output ; with \pm 500mV input the output will be \pm 55 μ A.

VOL L, VOL R

The main audio output from the volume control amplifier the signal to get output signals as high as 2V_{RMS} (+12dB) on a DC bias of 4.8V. Control is from +12dB to -26.75dB plus Mute with 1.25dB steps. This amplifier has short circuit protection and is intended to drive a SCART connector directly via AC coupling and meets the standard SCART drive requirements. These outputs feature high impedance mode for parallel connection.

S2 OUT L, S2 OUT R, S3 OUT L, S3 OUT R

These audio outputs are sourced directly from the audio MUX, and as a result do not include any volume control function. They will output a 1V_{RMS} signal biased at 4.8V. They are short circuit protected. These outputs feature high impedance mode for parallel connection and meet SCART drive requirement.

S2 RTN L, S2 RTN R, S3 RTN L, S3 RTN R

These pins allow auxiliary audio signals to be connected to the audio processor and hence makes use of the on-chip volume control. For additional details please refer to the audio switching table.

PIN DESCRIPTION (continued)**VIDEO PROCESSING****B-BAND IN**

AC-coupled video input from a tuner. $Z_{IN} > 10k\Omega \pm 25\%$. This drives an on-chip video amplifier. The other input of this amp is AC grounded by being connected to an internal V_{REF} . The video amplifier has selectable gain from 0dB to 12.7dB in 63 steps and its output signal can be selected normal or inverted.

UNCL DEEM

Deemphasized still unclamped output. It is also an input of the video matrix.

VIDEEM1

Connected to an external de-emphasis network (for instance 625 lines PAL de-emphasis).

VIDEEM2 / 22kHz

Connected to an external de-emphasis network (for instance 525 lines NTSC or other video de-emphasis). Alternatively a precise 22kHz tone may be output by I²C bus control.

CLAMP IN

This pin clamps the most negative extreme of the input (the sync tips) to $2.7V_{DC}$ (or appropriate voltage). The video at the clamp input is only $1V_{PP}$. This clamped video which is de-emphasised, filtered and clamped (energy dispersal removed) is normal, negative syncs, video. This signal drives the Video Matrix input called Normal Video.

It has a weak ($1.0\mu A \pm 15\%$) stable current source pulling the input towards GND. Otherwise the input impedance is very high at DC to 1kHz $Z_{IN} > 2M\Omega$. Video bandwidth through this is -1dB at 5.5MHz. The CLAMP input DC restore voltage is then used as a means for getting the correct DC voltage on the SCART outputs.

S3 VID RTN

This input can be driven for instance by the decoder. This input has a DC restoration clamp on its input. The clamp sink current is $1\mu A \pm 15\%$ with the buffer $Z_{IN} > 1M\Omega$.

S2 VID RTN, S1 VID RTN

External video input $1.0V_{pp}$ AC coupled 75Ω source impedance. This input has a DC restoration clamp on its input. The clamp sink current is $1\mu A \pm 15\%$ with the buffer $Z_{IN} > 1M\Omega$. This signal is an input to the Video Matrix.

S1 VID OUT, S2 VID OUT

Video drivers for SCART 1 and SCART 2. An external emitter follower buffer is required to drive

a 150Ω load. The average DC voltage to be 1.5V on the O/P. The signal is video $2.0V_{PP}$ 5.5MHz BW with sync tip = 1.2V. These pins get signals from the Video Matrix. The signal selected from the Video Matrix for output on this pin is controlled by a control register. This output also feature a high impedance mode for parallel connection.

S3 VID OUT

This output can drive for instance a decoder. Also it is able to pass 10MHz ; $Z_{OUT} < 75\Omega$. Video on this pin will be $2V_{PP}$. The black level of the output video signal can be adjusted through I²C bus control to easily interface with on-board Videocrypt decoder. This output feature an high impedance mode for parallel connection.

V 12V

+ 12V double bonded : ESD+guard rings and video circuit power.

V GND

Doubled bonded. Clean VID IN GND. Strategically placed video power ground connection to reduce video currents getting into the rest of the circuit.

CONTROL BLOCK**GND 5V**

The main power ground connection for the control logic, registers, the I²C bus interface, synthesizer & watchdog and XTOSC.

VDD 5V

Digital +5V power supply.

SCL

This is the I²C bus clock line. Clock = DC to 100kHz. Requires external pull up eg. $10k\Omega$ to 5V.

SDA

This is the I²C bus data line. Requires external pull up eg. $10k\Omega$ to 5V.

I/O / 22kHz

General purpose input output pin or 22kHz output.

XTL

This pin allows for the on-chip oscillator to be either used with a crystal to ground of 4MHz or 8MHz, or to be driven by an external clock source. The external source can be either 4MHz or 8MHz. A programmable bit in the control block removes a ± 2 block when the 4MHz option is selected.

HA

Hardware address with internal $135\mu A$ pull down. Chip address is 06 when this pin is grounded and chip address is 46 when connected to V_{DD} .

STV0056A

GENERAL BLOCK DIAGRAM

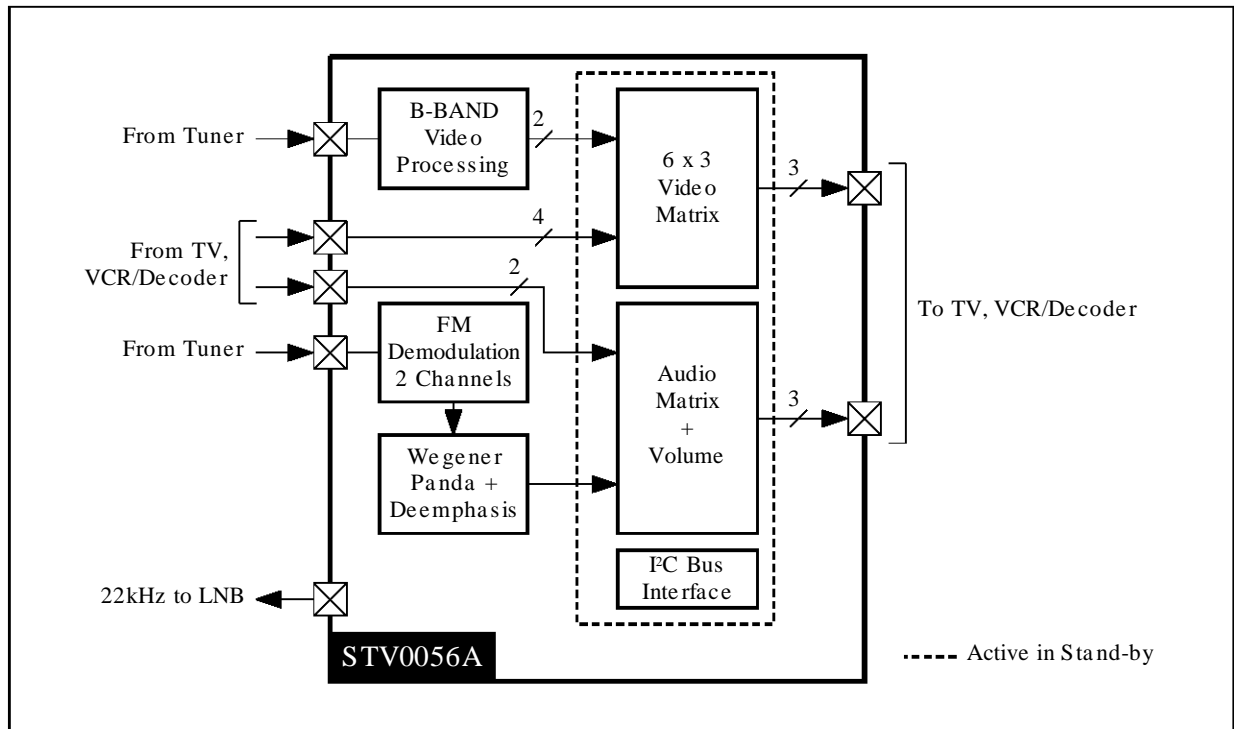

0056A-02.EPS

VIDEO PROCESSING BLOCK DIAGRAM

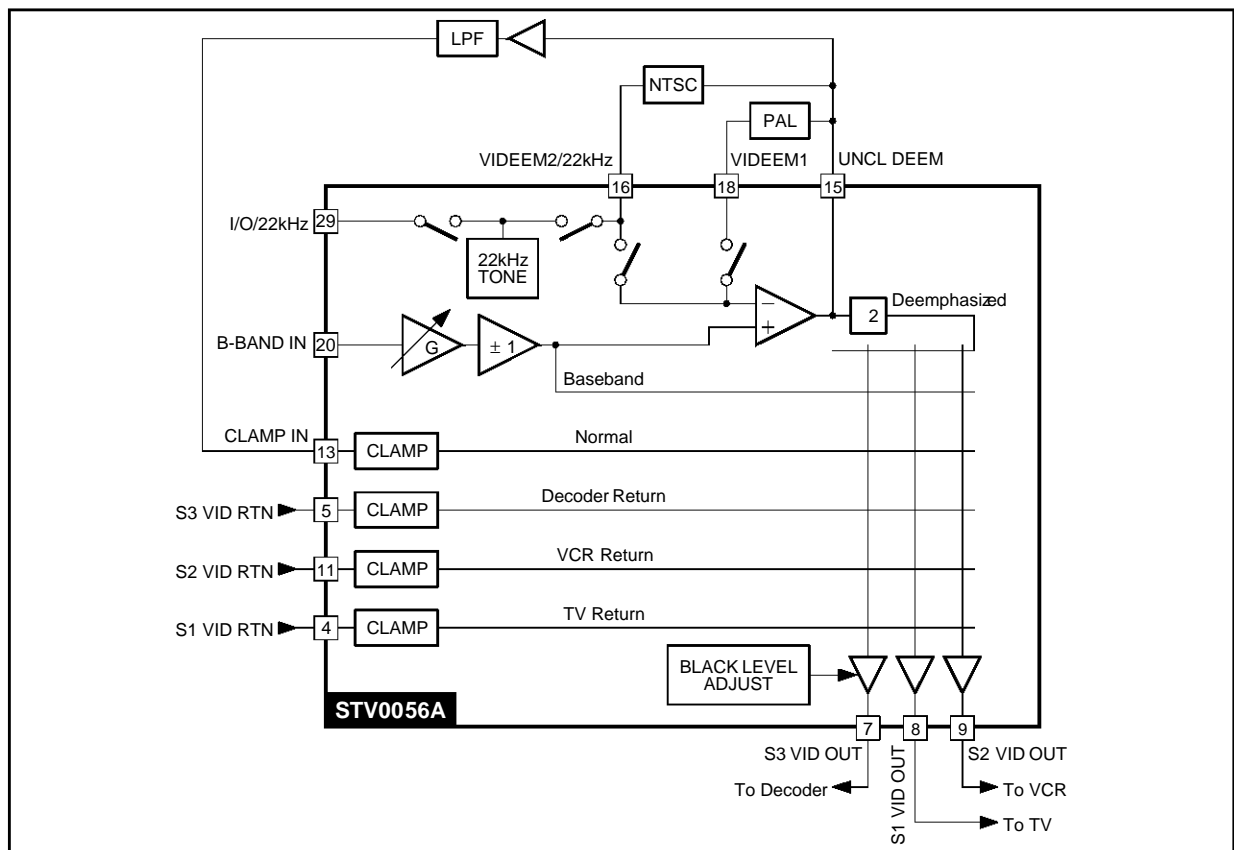

0056A-03.EPS

AUDIO PROCESSING BLOCK DIAGRAM (CHANNEL RIGHT)

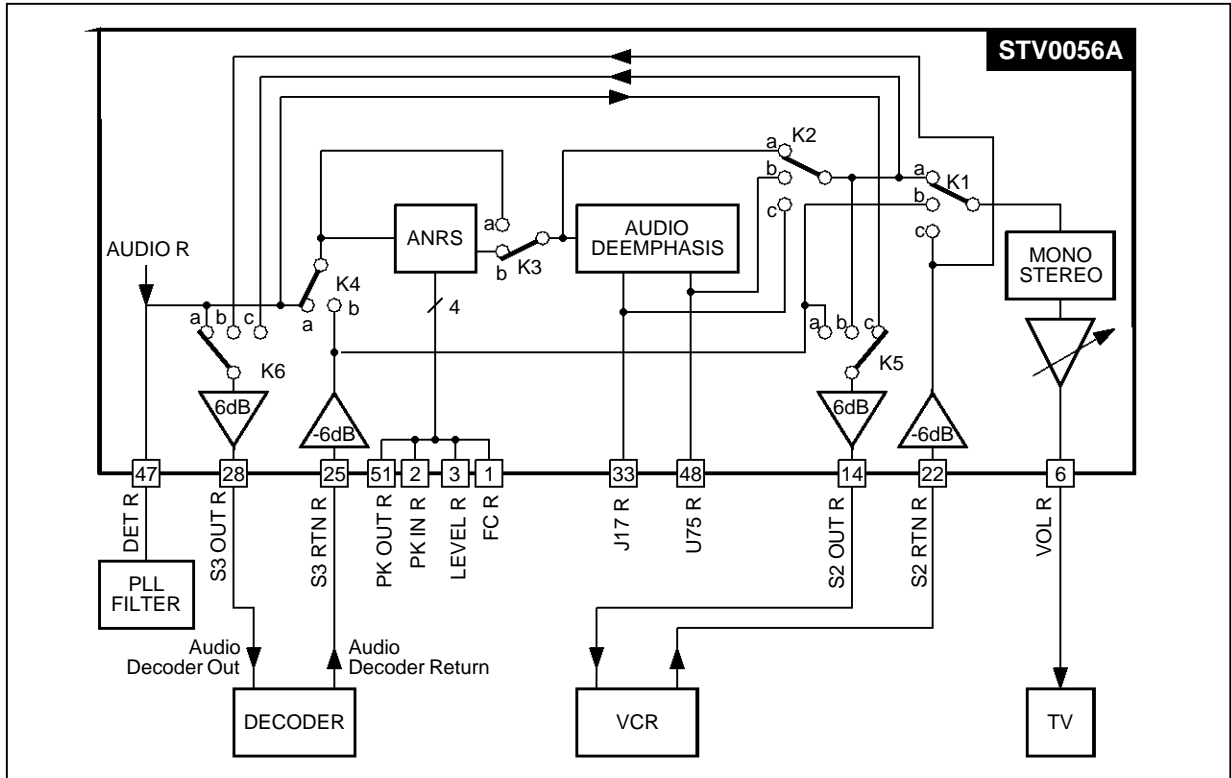

0056A-04.EPS

AUDIO PROCESSING BLOCK DIAGRAM (CHANNEL LEFT)

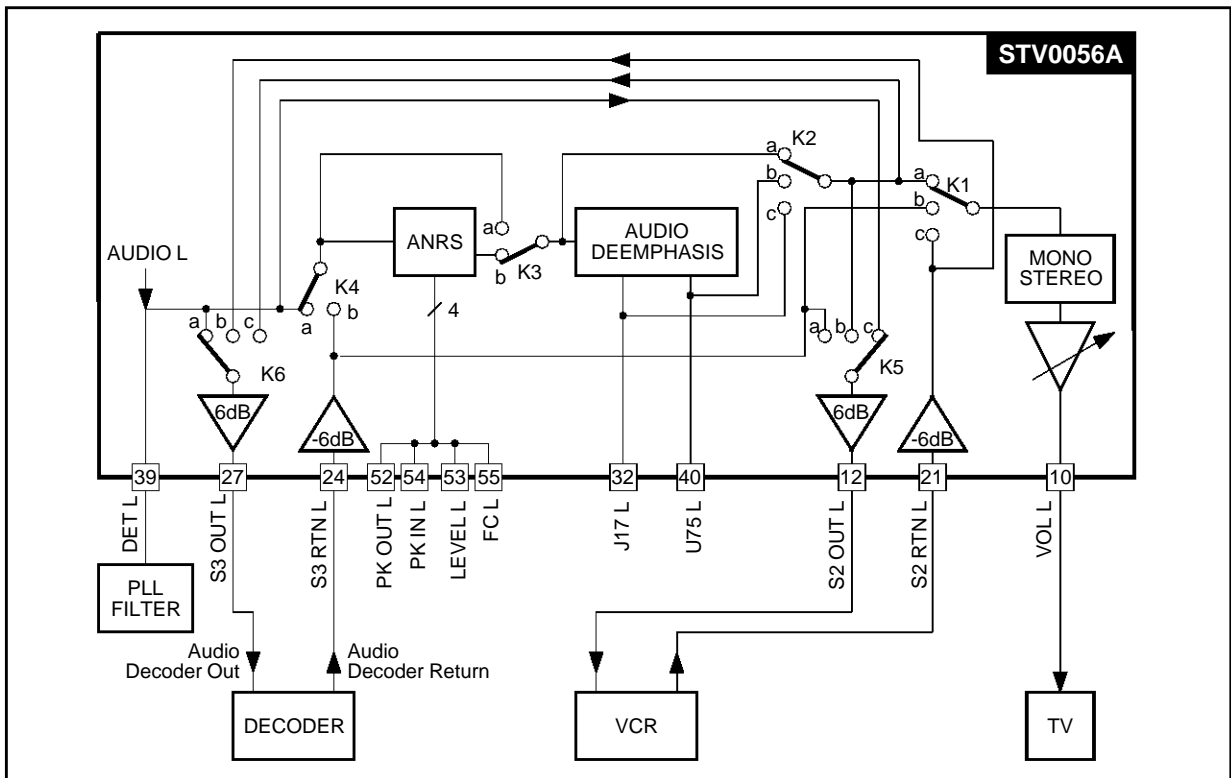

0056A-05.EPS

AUDIO SWITCHING

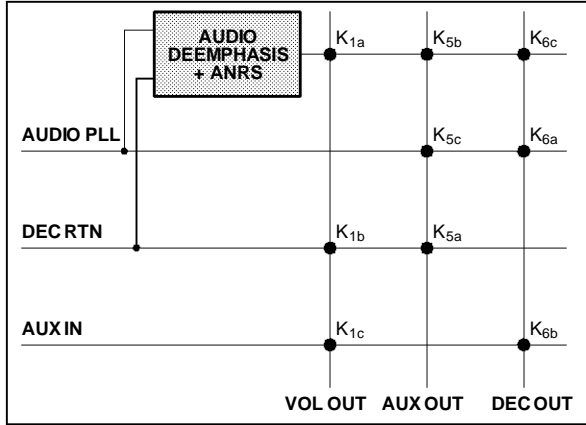

K4 : a → ANRS input non-scrambled audio
 b → ANRS input descrambled audio

K ₂	K ₃	
a	a	No ANRS, No De-emphasis
b ₁	a	No ANRS, 50μs
b ₂	a	No ANRS, 75μs
c	a	No ANRS, J17
a	b	ANRS, No De-emphasis
b ₁	b	ANRS, 50μs
b ₂	b	ANRS, 75μs
c	b	ANRS, J17

FM DEMODULATION BLOCK DIAGRAM

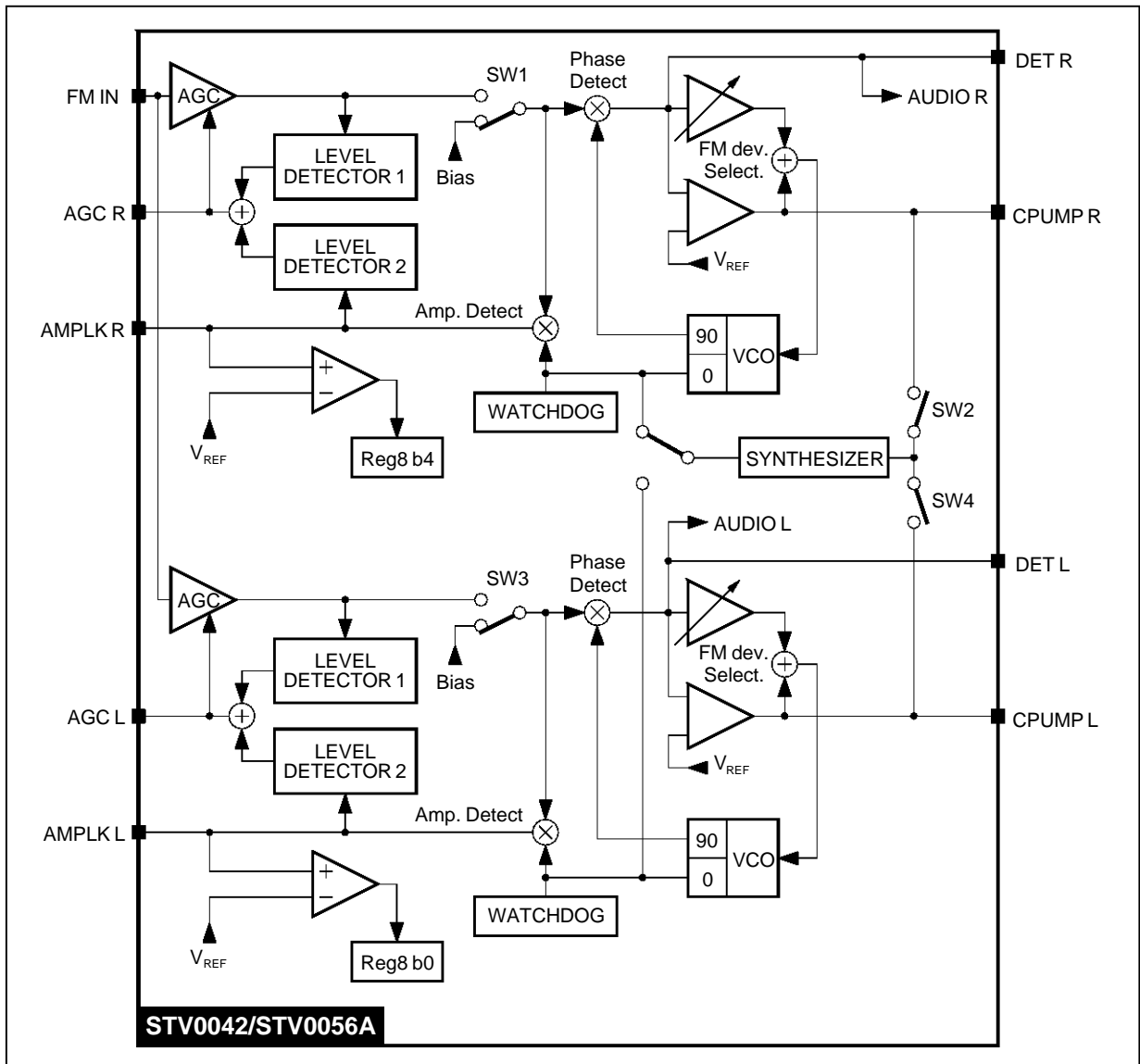

CIRCUIT DESCRIPTION

Video Section

The composite video is first set to a standard level by means of a 64 step gain controlled amplifier. In the case that the modulation is negative, an inverter can be switched in.

One of two different external video de-emphasis networks (for instance PAL and NTSC) is selectable by an integrated bus controlled switch.

Then energy dispersal is removed by a sync tip clamping circuit, which is used on all inputs to a video switching matrix, thus making sure that no DC steps occur when switching video sources.

The matrix can be used to feed video to and from decoders, VCR's and TV's.

A bus controlled black level adjustment circuit is provided on the decoder output allowing a direct connection to an on-board Videocrypt decoder.

Additionally all the video outputs are tristate type (high impedance mode is supported), allowing a simple parallel connections to the scarts (Twin tuner applications).

Audio Section

The two audio channels are totally independent except for the possibility given to output on both channels only one of the selected input audio channels.

To allow a very cost effective application, each channel uses PLL demodulation. Neither external complex filter nor ceramic filters are needed.

The frequency of the demodulated subcarrier is chosen by a frequency synthesizer which sets the frequency of the internal local oscillator by comparing its phase with the internally generated reference. When the frequency is reached, the microprocessor switches in the PLL and the demodulation starts. At any moment the microprocessor can read from the device (watchdog registers) the actual frequency to which the PLL is locked. It can also verify that a carrier is present at the wanted frequency (by reading AMPLK status bit) thanks to

a synchronous amplitude detector, which is also used for the audio input AGC.

In order to maintain constant amplitude of the recovered audio regardless of variations between satellites or subcarriers, the PLL loop gain may be programmed from 56 values.

Any frequency deviation can be accommodated (from $\pm 30\text{kHz}$ till $\pm 400\text{kHz}$).

Two different networks can be permanently connected for either $75\mu\text{s}$ or J17 de-emphasis. If $50\mu\text{s}$ de-emphasis is required, this can be inserted by an internal switch, thus allowing a worldwide application.

The STV0056A is intended to be compatible with Wegener Panda System.

Two types of audio outputs are provided: one is a fixed $1V_{\text{RMS}}$ and the other is a gain controlled $2V_{\text{RMS}}$ max. The control range being from $+12\text{dB}$ to -26.75dB with 1.25dB steps. This output can also be muted.

A matrix is implemented to feed audio to and from decoders VCR's and TV's.

Noise reduction system and de-emphasis can be inserted or by-passed through bus control.

Also all the audio outputs are tristate-type (high impedance mode is supported), allowing a simple parallel connections to the scarts (Twin tuner applications).

Others

A 22kHz tone is generated for LNB control.

It is selectable by bus control and available on one of the two pins connected to the external video de-emphasis networks. One general purpose I/O is also available on the STV0056A.

By means of the I^2C bus there is the possibility to drive the ICs into a low power consumption mode with active audio and video matrixes. Independantly from the main power mode, each individual audio and video output can be driven to high impedance mode.

STV0056A

ABSOLUTE MAXIMUM RATINGS

Symbol	Parameter	Value	Unit
V _{CC} V _{DD}	Supply Voltage	15 7.0	V V
P _{tot}	Total Power Dissipation	900	mW
T _{oper}	Operating Ambient Temperature	0, + 70	°C
T _{stg}	Storage Temperature	-55, + 150	°C

0056A-03.TBL

THERMAL DATA

Symbol	Parameter	Value	Unit
Rth(j-a)	Thermal Resistance Junction-ambient Max.	55	°C/W

0056A-04.TBL

DC AND AC ELECTRICAL CHARACTERISTICS

(V_{CC} = 12V, V_{DD} = 5V, T_{amb} = 25°C unless otherwise specified)

Symbol	Parameter	Test Conditions	Min.	Typ.	Max.	Unit
V _{CC} V _{DD}	Supply Voltage		11.4 4.75	12 5.0	12.6 5.25	V V
I _{QCC} I _{QDD}	Supply Current	All audio and all video outputs activated		55 8	70 15	mA mA
I _{QLPCC} I _{QLPDD}	Supply Current at Low Power Mode	All audio and all video outputs are in high impedance mode		27 6	35 9	mA mA

AUDIO DEMODULATOR

FMIN	FM Subcarrier Input Level (Pin FMIN for AGC action)	VCO locked on carrier at 6MHz 560kΩ load on AMPLOCK Pins 180kΩ load on DET Pins	5		500	mV _{PP}
DETH	Detector 1 and 2 (AMPLOCK Pins) (Threshold for activating Level Detector 2)	8mV _{PP} ≤ FMIN ≤ 500mV _{PP} Carrier without modulation	2.90	3.10	3.30	V
VCOMI	VCO Mini Frequency	V _{CC} : 11.4 to 12.6V, T _{amb} : 0 to 70°C			5	MHz
VCOMA	VCO Maxi Frequency		10			MHz
AP50	1kHz Audio Level at PLL output (DET Pins)	0.5V _{PP} 50kHz dev. FM input, Coarse deviation set to 50kHz (Reg. 05 = 36 _{HEX})	0.6	1	1.35	V _{PP}
APA50	1kHz Audio Level at PLL output (DET Pins)	0.5V _{PP} 50kHz dev. FM input, Coarse and fine settings used	0.92	1	1.08	V _{PP}
FMBW	FM Demodulator Bandwidth	Gain at 12kHz versus 1kHz 180kΩ, 82kΩ 22pF on DET Pins	0	0.3	1	dB
DPCO	Digital Phase Comparator Output Current (CPUMP Pins)	Average sink and source current to external capacitor		60		μA

AUTOMATIC NOISE REDUCTION SYSTEM

LRS	Output Level (Pins LEVEL)	1V _{PP} on left and right channel	0.9	1	1.1	V _{PP}
LDOR	Level Detector Output Resistance (Pins PK OUT)		4.0	5.4	6.8	kΩ
NDFT	Level Detector Fall Time Constant (Pins PK OUT)	External 22nF to GND and 1.2MΩ to V _{REF}		26.4		ms
NDLL	Bias Level (Pins PK OUT)	No audio in		2.40		V
LLCF	Noise Reduction Cut-off Frequency at Low Level Audio	100mV _{PP} on DET Pins, External capacitor 330pF (FC Pins)		0.85		kHz
HLCF	Noise Reduction Cut-off Frequency at High Level Audio	1V _{PP} on DET Pins, External capacitor 330pF (FC Pins)		7		kHz

0056A-05.TBL

DC AND AC ELECTRICAL CHARACTERISTICS (continued)
 ($V_{CC} = 12V$, $V_{DD} = 5V$, $T_{amb} = 25^{\circ}C$ unless otherwise specified)

Symbol	Parameter	Test Conditions	Min.	Typ.	Max.	Unit
AUDIO OUTPUT (Pins VOL OUT R, VOL OUT L)						
DCOL	DC Output Level			4.8		V
AOLN	Audio Output Level with Reg 00 = 1A	FM input as for APA50 No de-emphasis, No pre-emphasis No noise reduction	1.5	1.9	2.34	V_{PP}
AOL50	Audio Output Level with Reg 00 = 1A	FM input as for APA50 50 μ s de-emphasis, 27k Ω //2.7nF load No pre-emphasis, No noise reduction	2.0	3.3	4.0	V_{PP}
AOL75	Audio Output Level with Reg 00 = 1A	FM input as for APA50 75 μ s de-emphasis, 27k Ω //2.7nF load No pre-emphasis, No noise reduction	2.0	3.3	4.0	V_{PP}
AOL17	Audio Output Level with Reg 00 = 1A	FM input as for APA50 J17 de-emphasis, 36k Ω 4.7k Ω 8.2nF load No pre-emphasis, No noise reduction	2.0	3.2	4.0	V_{PP}
AMA1	Audio Output Attenuation with Mute-on. Reg 00 = 00.	1 V_{PP} - 1kHz from S2 RTN Pins	60	65		dB
MXAT	Max Attenuation before Mute. Reg 00 = 01.	1kHz, from S2 RTN Pins		32.75		dB
MXAG	Audio Gain. Reg 00 = 1F.	1kHz, from S2 RTN Pins	5	6	7	dB
ASTP	Attenuation of each of the 31 steps	1kHz		1.25		dB
THDA1	THD with Reg 00 = 1A	1 V_{PP} -1kHz from S2 RTN Pins		0.15		%
THDA2	THD with Reg 00 = 1A	2 V_{PP} -1kHz from S2 RTN Pins		0.3	1	%
THDFM	THD with Reg 00 = 1A	FM input as for APA50 75 μ s de-emphasis, ANRS ON		0.3	1	%
ACS	Audio Channel Separation	1 V_{PP} -1kHz on S2 RTN Pins	60	74		dB
ACSFM	Audio Channel Separation at 1kHz	- 0.5 V_{PP} - 50kHz deviation FM input on one channel - 0.5 V_{PP} no deviation FM input on the other channel - Reg 05 = 36 _{HEX} - 75 μ s de-emphasis, no ANRS		60		dB
SNFM	Signal to Noise Ratio	FM input as for APA50, 75 μ s de-emphasis, no ANRS, Unweighted		56		dB
SNFMNR	Signal to Noise Ratio	FM input as for APA50 75 μ s de-emphasis, ANRS ON, Unweighted		69		dB
Z_{OUTL} Z_{OUTH}	Audio Output Impedance	Low impedance mode High impedance mode	30	18 44	55	Ω k Ω

AUXILIARY AUDIO OUTPUT (Pins S2 OUT R, S2 OUT L, S3 OUT R, S3 OUT L)

DCOLAO	DC output level	Aux. input pins open circuit		4.8		V
AOLNS	Audio Output Level on S2 and S3	FM input as for APA50 No de-emphasis, No pre-emphasis No noise reduction	1.55	2	2.42	V_{PP}
AOL50S	Audio Output Level on S2 and S3	FM input as for APA50 50 μ s de-emphasis, 27k Ω //2.7nF load No pre-emphasis, No noise reduction	2.0	3.4	4.0	V_{PP}
AOL75S	Audio Output Level on S2 and S3	FM input as for APA50 75 μ s de-emphasis, 27k Ω //2.7nF load No pre-emphasis, No noise reduction	2.0	3.4	4.0	V_{PP}
AOL17S	Audio Output Level on S2 and S3	FM input as for APA50 J17 de-emphasis, 36k Ω 4.7k Ω 8.2nF load No pre-emphasis, No noise reduction	2.0	3.3	4.0	V_{PP}
AGAO	S2 to S3 Audio Gain and S3 to S2 Audio Gain	1kHz	-1	0	+1	dB
THDA02	THD on S2, Input in S3	2 V_{PP} - 1kHz from Aux input pins		0.04	0.2	%

0056A-06.TBL

STV0056A

DC AND AC ELECTRICAL CHARACTERISTICS (continued)

($V_{CC} = 12V$, $V_{DD} = 5V$, $T_{amb} = 25^{\circ}C$ unless otherwise specified)

Symbol	Parameter	Test Conditions	Min.	Typ.	Max.	Unit
AUXILIARY AUDIO OUTPUT (Pins S2 OUT R, S2 OUT L, S3 OUT R, S3 OUT L) (continued)						
THDAOFM	THD on S2 or S3	FM input as for APA50 75 μ s de-emphasis, no ANRS		0.3	1	%
$Z_{OUT L}$ $Z_{OUT H}$	Audio Output Impedance	Low impedance mode High impedance mode	30	60 44	100 55	Ω k Ω

I/O

V_{IL} V_{IH}	Low Level Input High Level Input		2.4		0.8	V V
V_{OL} V_{OH}	Low Level Output High Level Output	$I_{sink} = 2mA$ $I_{source} = 2mA$	3.2	0.2 4.6	0.4	V V
LNB _T	Tone Frequency		22.2	22.2	22.2	kHz
LNB _D	Tone Signal Duty Cycle	No load connected on I/O	49	50	51	%

RESET

RTCCU	End of Reset Threshold for V_{CC}	$V_{DD} = 5V$, V_{CC} going up		8.7		V
RTCCD	Start of Reset Threshold for V_{CC}	$V_{DD} = 5V$, V_{CC} going down		7.9		V
RTDDU	End of Reset Threshold for V_{DD}	$V_{CC} = 12V$, V_{DD} going up		3.8		V
RTDDD	Start of Reset Threshold for V_{DD}	$V_{CC} = 12V$, V_{DD} going down		3.5		V

COMPOSITE SIGNAL PROCESSING

VIDC	VID IN	External load current < 1 μ A	2.25	2.45	2.65	V
ZVI	VID IN Input Impedance		7	11	14	k Ω
DEODC	DC Output Level (Pins VIDEEM)		2.25	2.45	2.65	V
DEOMX	Max AC Level before Clipping (Pins VIDEEM)	GV = 0dB, Reg 01 = 00	2			V _{PP}
DGV	Gain error vs GV @ 100kHz	GV = 0 to 12.7dB, Reg 01 = 00 → 3F	-0.5	0	0.5	dB
INVG	Inverter Gain		-0.9	-1	-1.1	
VISOG	Video Input to SCART Outputs Gain	De-emphasis amplifier mounted in unity gain, Normal video selected	-1	0	1	dB
DEBW	Bandwidth for 1V _{PP} input measured on Pins VIDEEM	@ - 3dB with GV = 0dB, Reg 01 = 00	10			MHz
DFG	Differential Gain on Sync Pulses measured on Pins VIDEEM	GV = 0dB, 1V _{PP} CVBS + 0.5V _{PP} 25Hz sawtooth (input : VID IN)			1	%
ITMOD	Intermodulation of FM sub-carriers with chroma subcarrier	7.02 and 7.2MHz sub-carriers, 12.2dB lower than chroma		-60		dB

CLAMP STAGES (Pins CLAMP IN, S1, S2, S3 VID RTN)

ISKC	Clamp Input Sink Current	$V_{IN} = 3V$	0.5	1	1.5	μ A
ISCC	Clamp Input Source Current	$V_{IN} = 2V$	40	50	60	μ A

VIDEO MATRIX

XTK	Output Level on any Output when 1V _{PP} CVBS input is selected for any other output	@ 5MHz		-60		dB
BFG	Output Buffer Gain (Pins S1 VID OUT, S2 VID OUT, S2 VID OUT)	@ 100kHz	1.87	2	2.13	
DCOLVH	DC Output Level	High impedance mode		0	0.2	V
$Z_{OUT HV}$	Video Output Impedance	High impedance mode	16	23	30	k Ω
VCL	Sync Tip Level on Selected Outputs (Pins S1 VID OUT, S2 VID OUT)	1V _{PP} CVBS through 10nF on input	1.05	1.3	1.55	V
VCL S3	Sync Tip Level at S3 VID OUT with Black Level Adjust	Register 4 b6 b7 0 0 0 1 1 0 1 1		1.36 1.52 1.67 1.84		V V V V

PIN INTERNAL CIRCUITRY

S1 VID RTN, S2 VID RTN, S3 VID RTN, CLAMP IN

50µA source is active only when VIDIN < 2.7V.

Figure 1

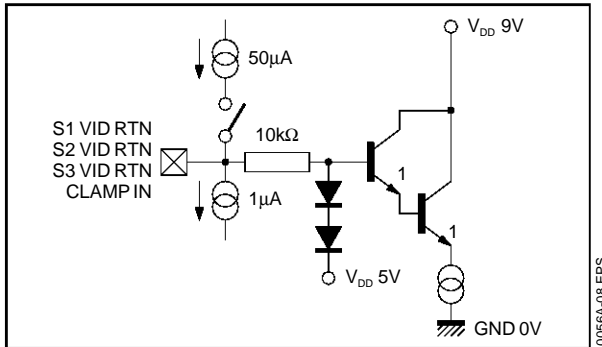

S3 VID OUT

I blacklevel is I²C programmable from source 16µA to sink 33µA equivalent to an offset voltage of -150mV to + 300mV.

The 60Ω collector resistor is for short cct. protection.

Figure 2

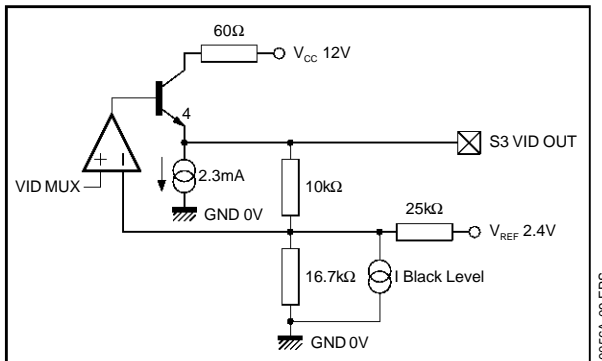

S1 VID OUT, S2 VID OUT

Same as above but with no black level adjustment.

Figure 3

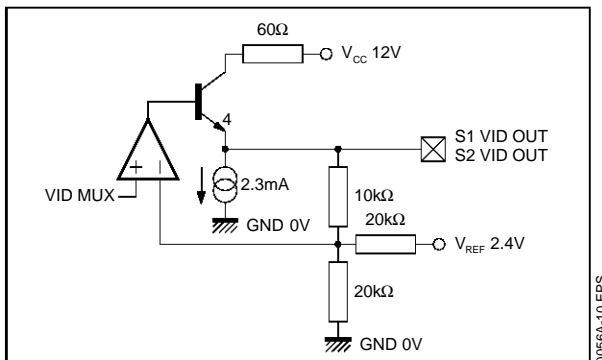

UNCL DEEM

Same as above but with no black level adjustment and slightly different gain.

Figure 4

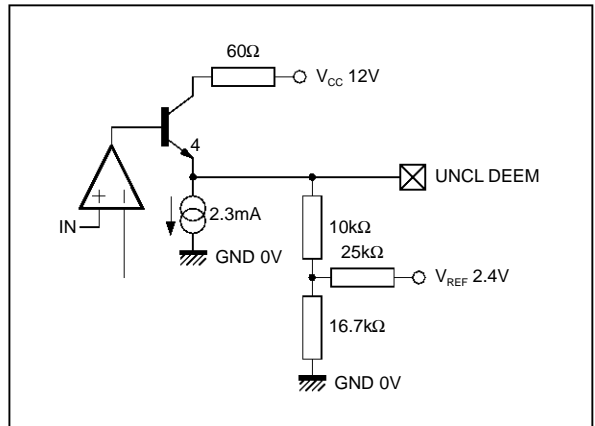

VIDEEM1

Ron of the transistor gate is ≈10kΩ.

Figure 5

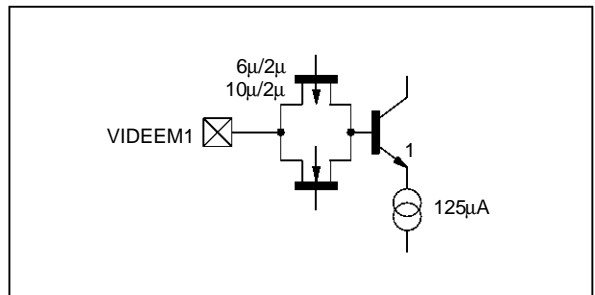

VIDEEM2/ 22kHz

Ron of the transistor gate is ≈10kΩ.

Figure 6

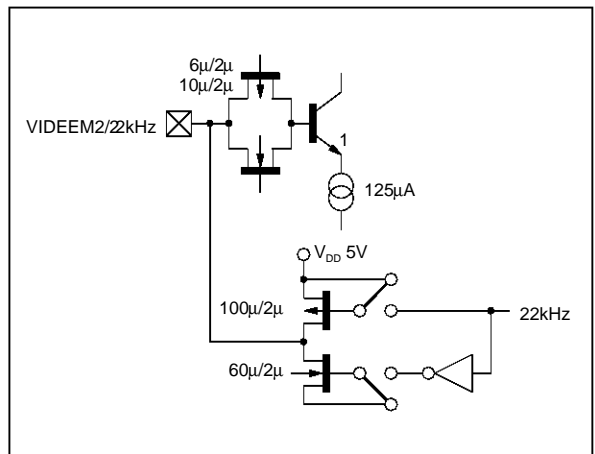

PIN INTERNAL CIRCUITRY (continued)

VID IN

Figure 7

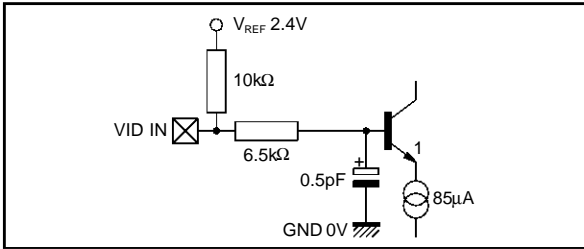

0056A-14.EPS

PK OUT R, PK OUT L

Figure 8

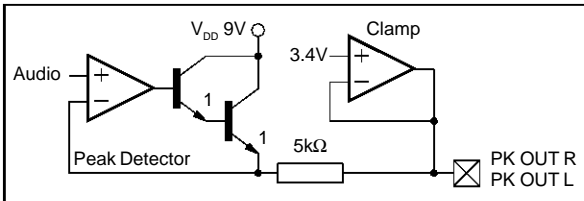

0056A-15.EPS

FC L, FC R

Ivar is controlled by the peak det audio level max. ±15μA (1V_{PP} audio).

Figure 9

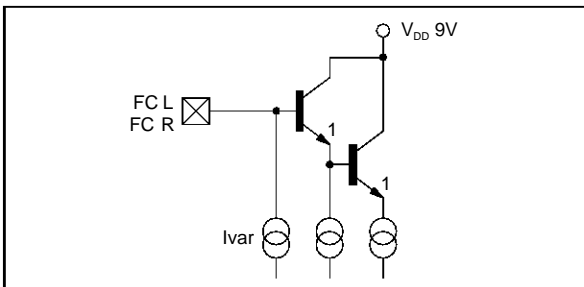

0056A-16.EPS

VOL OUT R, VOL OUT L

Audio output with volume and scart driver with +12dB of gain for up to 2V_{RMS}. The opamp has a push-pull output stage.

Figure 10

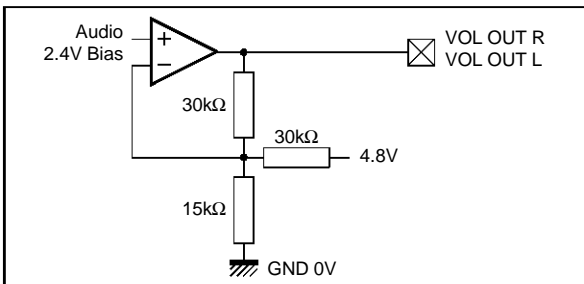

0056A-17.EPS

S2 OUT L, S2 OUT R, S3 OUT L, S3 OUT R

Same as above but with gain fixed at +6dB.

Figure 11

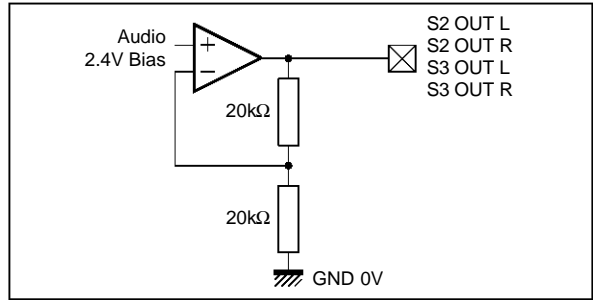

0056A-18.EPS

S2 RTN L, S2 RTN R, S3 RTN L, S3 RTN R

4.8V bias voltage is the same as the bias level on the audio outputs.

Figure 12

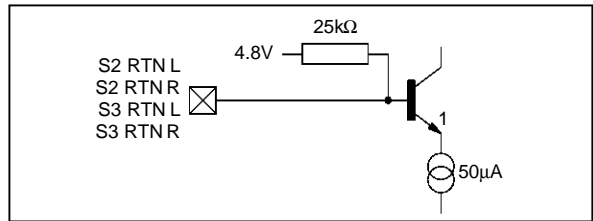

0056A-19.EPS

FM IN

The other input for each channel is internally biased in the same way via 10kΩ to the 2.4V V_{REF}.

Figure 13

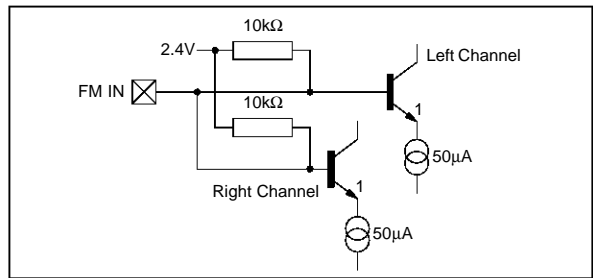

0056A-20.EPS

I_{REF}

The optimum value if I_{REF} is 50μA ±2% so an external resistor of 47.5kΩ ±1% is required.

Figure 14

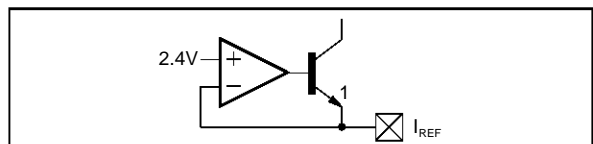

0056A-21.EPS

PIN INTERNAL CIRCUITRY (continued)

AMPLK L, AMPLK R, AGC L, AGC R
I2 and I1 from the amplitude detecting mixer.

Figure 23

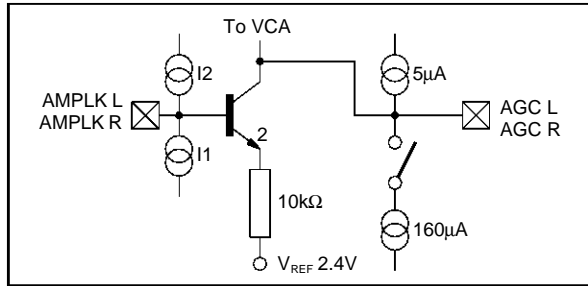

0056A-30.EPS

VREF
The 400μA source is off during stand-by mode.

Figure 24

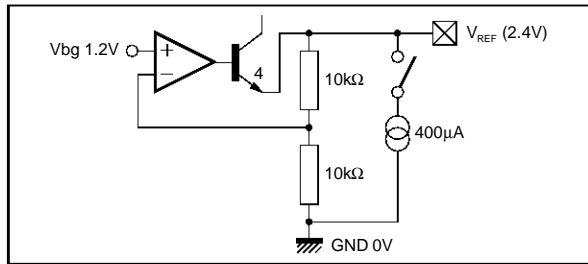

0056A-31.EPS

LEVEL L, LEVEL R

Figure 25

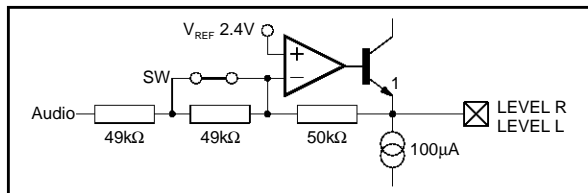

0056A-32.EPS

PK IN L, PK IN R

Figure 26

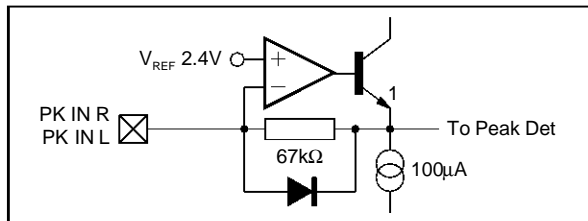

0056A-33.EPS

V 12V
Doubled bonded (two bond wires and two pads for one package pin) :
- One pad is connected to all of the 12V ESD and video guard rings.
- The second pad is connected to power up the video block.

V GND
Doubled bonded :
- One pad is connected to power-up all of the video mux and I/O.
- The second pad is only as a low noise GND for the video input.

VDD 5V, GND 5V
Connected to XTL oscillator and the bulk of the CMOS logic and 5V ESD.

A GND
Doubled bonded :
- One pad connected to the left VCO, dividers, mixers and guard ring. the guard connection is star connected directly to the pad.
- The second pad is connected to both AGC amps and the deemphasis amplifiers, frequency synthesis and FM deviation selection circuit for both channels.

A 12V
Doubled bonded :
- One pad connected to the ESD and guard ring.
- The second pad is connected to the main power for all of the audio parts.

A GND R
Doubled bonded :
- One pad connected to the right VCO, dividers, mixers and guard ring. The guard connection is star connected directly to the pad.
- The second pad is connected to the bias block, audio noise reduction, volume, mux and ESD.
A third bond wire on this pin is connected directly to the die pad (substrate).

Figure 27

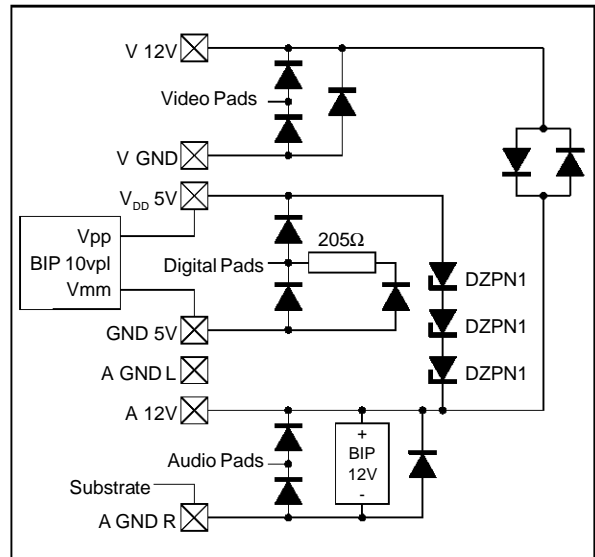

0056A-34.EPS

I²C PROTOCOL**1) WRITING** to the chip**S**-Start Condition**P**-Stop Condition**CHIP ADDR** - 7 bits. Programmable 06H or 46H (STV0056A only) with Pin HA.**W**-Write/Read bit is the 8th bit of the chip address.**A**-ACKNOWLEDGE after receiving 8 bits of data/adress.**REG ADDR** Address of register to be written to, 8 bits of which bits 3, 4, 5, 6 & 7 are 'X' or don't care ie *only the first 3 bits are used*.**DATA** 8 bits of data being written to the register. All 8 bits must be written to at the same time.**REG ADDR/A/DATA/A** can be repeated, the write process can continue until terminated with a STOP condition. If the **REG ADDR** is higher than 07 then IIC PROTOCOL will still be met (ie an **A** generated).**Example :**

S	06	W	A	00	A	55	A	01	A	8F	//	A	P
---	----	---	---	----	---	----	---	----	---	----	----	---	---

2) READING from the chip

When reading, there is an auto-increment feature. This means any read command always starts by reading Reg 8 and will continue to read the following registers in order after each acknowledge or until there is no acknowledge or a stop. This function is cyclic that is it will read the same set of registers without re-addressing the chip. There are two modes of operation as set by writing to bit 7 of register 0. Read 3 registers in a cyclic fashion or all 5 registers in a cyclic fashion. Note only the last 5 of the 11 registers can be read.

Reg0 bit 7 = L ⇒ Start / chip add / R / A / Reg 8 / A / Reg 9 / A / Reg 0A / A / Reg 8 / A / Reg 9 / A / Reg 0A / ... / P /

Reg0 bit 7 = H ⇒ Start / chip add / R / A / Reg 8 / A / Reg 9 / A / Reg 0A / A / Reg 7 / A / Reg 6 / A / Reg 8 / A / Reg 9 / A / Reg 0A / A / Reg 7 / A / Reg 6 / ... / P /

CONTROL REGISTERS**Reg 0 write only**Bit (default 00_{HEX})

- 0 L Select 5 bits audio volume control 00H = MUTE
- 1 L Select 5 bits audio volume control 01H = -26.75dB
- 2 L Select 5 bits audio volume control :: : :
- 3 L Select 5 bits audio volume control 1.25dB steps up to
- 4 L Select 5 bits audio volume control 1FH = +12dB
- 5 L Audio mux switch K4 - ANRS I/P select (L = PLL)
- 6 L Audio mux switch K3 - ANRS select (L = no ANRS, H = ANRS)
- 7 L L = read 3 registers, H = read 5 registers

Reg 1 write onlyBit (default 00_{HEX})

- 0 L Select video gain bits
- 1 L Select video gain bits 00H = 0dB
- 2 L Select video gain bits 01H = +0.202dB
- 3 L Select video gain bits 02H = +0.404dB
- 4 L Select video gain bits n = + 0.202 dB * n
- 5 L Select video gain bits 3FH = + 12.73 dB
- 6 L Selected video invert (H = inverted, L = non inverted)
- 7 L Video deemphasis 1 / Video deemphasis 2 (L : V_{ID} De-em 1)

CONTROL REGISTERS (continued)**Reg 2 write only**Bit (default F7_{HEX})

- 0 H Select video source for scart 1 O/P
- 1 H Select video source for scart 1 O/P
- 2 H Select video source for scart 1 O/P
- 3 L Select 4.000MHz or 8.000MHz clock speed (L = 8MHz)
- 4 H Select audio source for volume output (Switch K1)
- 5 H Select audio source for volume output (Switch K1)
- 6 H Select Left/Right/Stereo for volume output
- 7 H Select Left/Right/Stereo for volume output

Reg 3 write onlyBit (default F7_{HEX})

- 0 H Select video source for scart 2 O/P
- 1 H Select video source for scart 2 O/P
- 2 H Select video source for scart 2 O/P
- 3 L Video deemphas 2 / 22kHz (H : 22kHz)
- 4 H Select audio source for Scart 2 output (Switch K5)
- 5 H Select audio source for Scart 2 output (Switch K5)
- 6 H Audio deemphasis select (Switch K2)
- 7 H Audio deemphasis select (Switch K2)

Reg 4 write onlyBit (default BF_{HEX})

- 0 H Select source for video decoder O/P
- 1 H Select source for video decoder O/P
- 2 H Select source for video decoder O/P
- 3 H Stand-by or low power mode (H = low power)
- 4 H Select audio source for Scart 3 output (Switch K6)
- 5 H Select audio source for Scart 3 output (Switch K6)
- 6 L Black level adjust on Scart 3 video
- 7 H Black level adjust on Scart 3 video

Reg 5 write onlyBit (default B5_{HEX})

- 0 H FM deviation selection -- default value for 50kHz modulation
- 1 L FM deviation selection
- 2 H FM deviation selection
- 3 L FM deviation selection
- 4 H FM deviation selection
- 5 H FM deviation selection (L = double the FM deviation)
- 6 L Select 22kHz for I/O (Pin 29 / STV0056A)
- 7 H Select TP50a (H) or I/O (Pin 29 / STV0056A). TP50a for test only.

Reg 6 write/readBit (default 86_{HEX})

- 0 L Status of I/O
- 1 H Select data direction of I/O 1 (H = output)
- 2 H Select frequency synthesizer 1 OFF/ON (L = OFF)
- 3 L Select frequency synthesizer 2 OFF/ON (L = OFF)
- 4 L Select RF source (L = OFF) to FM det 1
- 5 L Select RF source (L = OFF) to FM det 2
- 6 L Select frequency for PLL synthesizer - LSB (bit 0) of 10-bit value
- 7 H Select frequency for PLL synthesizer - bit 1 of 10-bit value

CONTROL REGISTERS (continued)**Reg 7 write/read**Bit (default AF_{HEX})

- 0 H Select frequency for PLL synthesizer - bit 2 of 10-bit value
- 1 H Select frequency for PLL synthesizer
- 2 H Select frequency for PLL synthesizer
- 3 H Select frequency for PLL synthesizer
- 4 L Select frequency for PLL synthesizer
- 5 H Select frequency for PLL synthesizer
- 6 L Select frequency for PLL synthesizer
- 7 H Select frequency for PLL synthesizer - bit 9, MSB (10th bit) of 10-bit value

Reg 8 read only

Bit

- 0 Subcarrier detection (DET 1) (L = No subcarrier)
- 1 Not used
- 2 Read frequency of watchdog 1 - LSB (bit 0) of 10-bit value
- 3 Read frequency of watchdog 1 - bit 1 of 10-bit value
- 4 Subcarrier detection (DET 2) (L = No subcarrier)
- 5 Not used
- 6 Read frequency of watchdog 2 - bit 0 of 10-bit value
- 7 Read frequency of watchdog 2 - bit 1 of 10-bit value

Reg 9 read onlyBit (default AF_{HEX})

- 0 Read frequency of watchdog 1 - bit 2 of 10-bit value
- 1 Read frequency of watchdog 1
- 2 Read frequency of watchdog 1
- 3 Read frequency of watchdog 1
- 4 Read frequency of watchdog 1
- 5 Read frequency of watchdog 1
- 6 Read frequency of watchdog 1
- 7 Read frequency of watchdog 1 - bit 9, MSB (10th bit) of 10-bit

Reg 0A read only

Bit

- 0 Read frequency of watchdog 2 - bit 2 of 10-bit value
- 1 Read frequency of watchdog 2
- 2 Read frequency of watchdog 2
- 3 Read frequency of watchdog 2
- 4 Read frequency of watchdog 2
- 5 Read frequency of watchdog 2
- 6 Read frequency of watchdog 2
- 7 Read frequency of watchdog 2 - bit 9, MSB (10th bit) of 10-bit

STV0056A

CONTROL REGISTERS (continued)

Video Mux Truth Tables

Register 2 <0:2> ⇒ Scart 1 video output control

Register 3 <0:2> ⇒ Scart 2 video output control

Register 4 <0:2> ⇒ Scart 3 decoder output control

The truth table for the three scart outputs are the same.

Register 2/3/4			Video Output
Bit<2>	Bit<1>	Bit<0>	
0	0	0	Baseband video
0	0	1	De-emphasized video
0	1	0	Normal video
0	1	1	Scart 3 return
1	0	0	Scart 2 return
1	0	1	Scart 1 return
1	1	0	Nothing selected
1	1	1	High Z or low power (default)

Register 4		Black Level Adjust on Scart 3
Bit <7>	Bit <6>	
0	0	-150mV
1	0	0 (default)
0	1	+150mV
1	1	+300mV

Audio Mux Truth Tables

Register 2		Switch K1/Audio Source Selection for Volume Output
Bit <5>	Bit <4>	Volume Output
0	0	A Audio deemphasis (K2 switch O/P)
1	0	C Scart 2 return
0	1	B Scart 3 return
1	1	- High Z or low power (default)

Register 3		Switch K2/Audio Deemphasis
Bit <7>	Bit <6>	Audio Deemphasis
0	0	A No deemphasis
1	0	C J17
0	1	B 50µs
1	1	B 75µs (default)

Register 0		Switch K3 & K4
Bit <6>	Bit <5>	ANRS I/O Select
0	X	A Noise reduction OFF
1	X	B Noise reduction ON (default)
X	0	A I/P = PLL
X	1	B I/P = Scart 3 return

Register 3		Switch K5/Audio Source Selection for Scart 2
Bit <5>	Bit <4>	Aux Audio Output
0	0	C PLL output
1	0	A Scart 3 return
0	1	B Audio deemphasis (K2 switch O/P)
1	1	- High Z or low power state (default)

Register 4		Switch K6/Audio Source Selection for Scart 3
Bit <5>	Bit <4>	Audio Decoder Output
0	0	A PLL output
1	0	C Audio deemphasis (K2 switch O/P)
0	1	B Scart 2 return
1	1	- High Z or low power state (default)

CONTROL REGISTERS (continued)

Register 2		Left / Right / Stereo on Volume Output
Bit <7>	Bit <6>	
0	0	Mono left / channel 1
1	0	Mono right / channel 2
1	1	Stereo left & right (default)

Register 5 : FM Deviation Selection

4	3	2	1	0	Selected Nominal Carrier Modulation	
					Bit 5 = 0	Bit 5 = 1
0	0	0	0	0	Do not use	cal : do not use = 0.3373V offset on VCO
0	0	0	0	1	Do not use	cal : do not use = 0.3053V offset on VCO
0	0	0	1	0	Do not use	cal : do not use = 0.2763V offset on VCO
0	0	0	1	1	Cal. set. (2V)	calibration setting (1V offset on VCO)
0	0	1	0	0	592kHz	296kHz modulation
0	0	1	0	1	534kHz	267kHz modulation
0	0	1	1	0	484kHz	242kHz
0	0	1	1	1	436kHz	218kHz
0	1	0	0	0	396kHz	198kHz
0	1	0	0	1	358kHz	179kHz
0	1	0	1	0	322kHz	161kHz
0	1	0	1	1	292kHz	146kHz
0	1	1	0	0	266kHz	133kHz
0	1	1	0	1	240kHz	120kHz
0	1	1	1	0	218kHz	109kHz
0	1	1	1	1	196kHz	98.3kHz
1	0	0	0	0	179kHz	89.7kHz
1	0	0	0	1	161kHz	80.9kHz
1	0	0	1	0	146kHz	73.1kHz
1	0	0	1	1	122kHz	66.0kHz
1	0	1	0	0	120kHz	60.0kHz
1	0	1	0	1	109kHz	54.4kHz = default power up state
1	0	1	1	0	98kHz	49.1kHz
1	0	1	1	1	89kHz	44.3kHz
1	1	0	0	0	78kHz	39.8kHz
1	1	0	0	1	71kHz	35.9kHz
1	1	0	1	0	65kHz	32.4kHz
1	1	0	1	1	58kHz	29.1kHz
1	1	1	0	0	53kHz	26.7kHz
1	1	1	0	1	48.6kHz	24.3kHz
1	1	1	1	0	43.8kHz	21.9kHz
1	1	1	1	1	39.6kHz	19.7kHz

Example : Default power up state 54.4kHz \Rightarrow \pm 54.4kHz.

Register 1 Bit <7>	Register 3 Bit <3>	Video Deemphasis/22kHz
0	0	Deemphasis 1 (default)
0	1	Deemphasis 1 + 22kHz
1	0	Deemphasis 2
1	1	Deemphasis 2

Register 5		Digital I/O (STV0056A pin 29)
Bit <7>	Bit <6>	
0	0	I/O (refer to Register 6 Bit <0> Bit <1>)
0	1	22kHz
1	0	Do not use (for test only) (default)
1	1	22kHz

FM DEMODULATION SOFTWARE ROUTINE

With the STV0056A circuit, for each channel, three steps are required to achieve a FM demodulation :

- 1st step :To set the demodulation parameters :
 - FM deviation selection,
 - Subcarrier frequency selection.
- 2nd step : To implement a waiting loop to check the actual VCO frequency.
- 3rd step :To close the demodulation phase locked loop (PLL).

Referring to the FM demodulation block diagram (page 12), the frequency synthesis block is common to both channels (left and right) ; consequently

two complete sequences have to be done one after the other when demodulating stereo pairs.

Detailed Description

Conventions :

- R = Stands for Register
- B = Stands for Bit

Example : R05 B2 = Register 05, Bit 2

For clarity, the explanations are based on the following example : stereo pair 7.02MHz/L 7.20MHz/R, deviation ±50kHz max.

1st STEP (LEFT) : SETTING THE DEMODULATION PARAMETERS

A. The FM deviation is selected by loading R5 with the appropriate value. (see R5 truth table).

NB : Very wide deviations (up to ±592kHz) can be accommodated when R5 B5 is low.

Corresponding bandwidth can be calculated as follows :

$Bw \approx 2$ (FM deviation + audio bandwidth)

$Bw \approx 2$ (value given in table + audio bandwidth)

In the example :

R5 Bits	7	6	5	4	3	2	1	0
	X	X	1	1	0	1	1	0

B. The subcarrier frequency is selected by launching a frequency synthesis (the VCO is driven to the wanted frequency). This operation requires two actions :

- To connect the VCO to the frequency synthesis loop. Referring to the FM block diagram (page 12):
 - SW4 closed ⇒ R6 B2 = H
 - SW3 to bias ⇒ R6 B4 = L
 - SW2 to bias ⇒ R6 B3 = L
 - SW1 opened ⇒ R6 B5 = L

- To load R7 and R6 B6 B7 with the value corresponding to the left channel frequency. This 10 bits value is calculated as follows :

Subcarrier frequency = coded value x 10kHz
(10kHz is the minimum step of the frequency synthesis function)

Considering that the tuning range is comprised between 5 to 10MHz, the coded value is a number between 500 and 1000 ($2^{10} = 1024$) then 10 bits are required.

Example :

$7.02\text{MHz} = 702 \times 10\text{kHz}$

$702 \Rightarrow 1010\ 1111\ 10 \Rightarrow \text{AF} + 10$

R7 is loaded with AF and R6 B6 : L, R6 B7 : H.

The Table 1 gives the setting for the most common subcarrier frequencies.

Table 1 : Frequency Synthesis Register Setting for the Most Common Subcarrier Frequencies

Subcarrier Frequency (MHz)	Register 7 (Hex)	Register 6	
		Bit 7	Bit 6
5.58	8B	1	0
5.76	90	0	0
5.8	91	0	0
5.94	94	1	0
6.2	9B	0	0
6.3	9D	1	0
6.4	A0	0	0
6.48	A2	0	0
6.5	A2	1	0
6.6	A5	0	0
6.65	A6	0	1
6.8	AA	0	0
6.85	AB	0	1
7.02	AF	1	0
7.20	B4	0	0
7.25	B5	0	1
7.38	B8	1	0
7.56	BD	0	0
7.74	C1	1	0
7.85	C4	0	1
7.92	C6	0	0
8.2	CD	0	0
8.65	D8	0	1

FM DEMODULATION SOFTWARE ROUTINE (continued)**2nd STEP (LEFT) :****VCO FREQUENCY CHECKING (VCO)**

This second step is actually a waiting loop in which the actual running frequency of the VCO is measured.

To exit of this loop is allowed when : Subcarrier Frequency - 10kHz \leq Measured Frequency \leq Subcarrier Frequency + 10kHz (\pm 10kHz is the maximum dispersion of the frequency synthesis function).

In practice, R8 B2 B3 and R9 are read and compared to the value loaded in R6 B6 B7 and R7 \pm 1 bit.

Note :

The duration of this step depends on how large is frequency difference between the start frequency and the targeted frequency. Typically :

- the rate of change of the VCO frequency is about 3.75MHz/s ($C_{\text{pump}} = 10\mu\text{F}$)
- In addition to this settling time, 100ms must be added to take into account the sampling period of the watchdog.

3rd STEP (LEFT)

The FM demodulation can be started by connecting the VCO to the phase locked loop (PLL).

In practice :

- SW3 closed \Rightarrow R6 B4 = H
- SW4 opened \Rightarrow R6 B2 = L

After this sequence of 3 steps for left channel, a similar sequence is needed for the right channel.

Note :

In the sequence for the right, there is no need to again select the FM deviation (once is enough for the pair).

General Remark

Before to enable the demodulated signal to the audio output, it is recommended to keep the muting and to check whether a subcarrier is present at the wanted frequency. Such an information is available in R8 B0 and R8 B4 which can be read.

Two different strategies can be adopted when enabling the output :

- Either both left and right demodulated signals are simultaneously authorized when both channel are ready.
- Or while the right channel sequence is running, the already ready left signal is sent to the left and right outputs and the real stereo sound L/R is output when both channels are ready. This second option gives sound a few hundreds of ms before the first one.

STV0056A

TYPICAL APPLICATION (3 SCARTS, PAL/SECAM Europe Application)

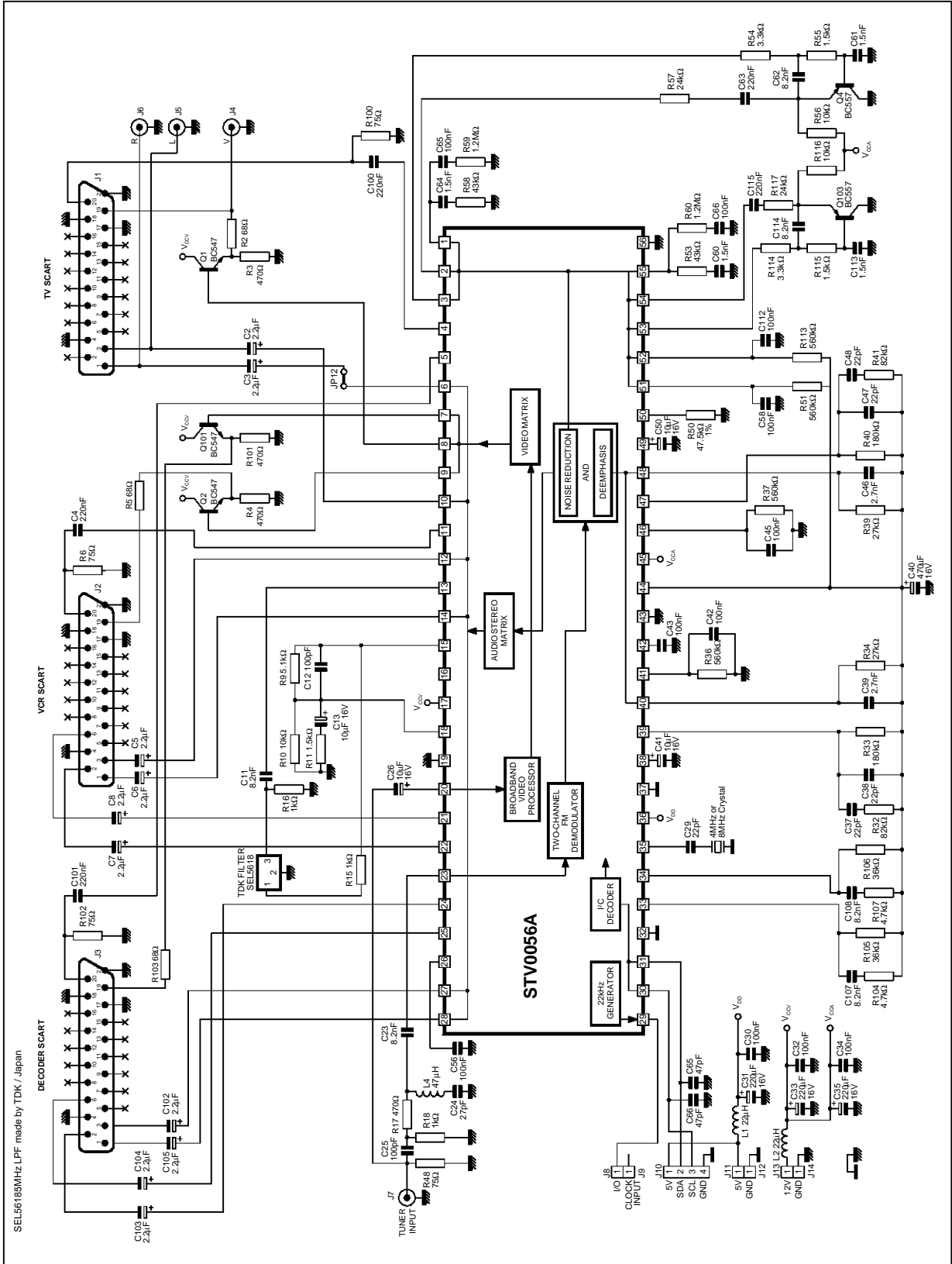

0056A-35.EPS

TWIN TUNER APPLICATION

Easy parallel connection of the outputs to the scarts without any additional switching hardware. This configuration is possible due to the high impedance mode that can be selected for each audio and video outputs.

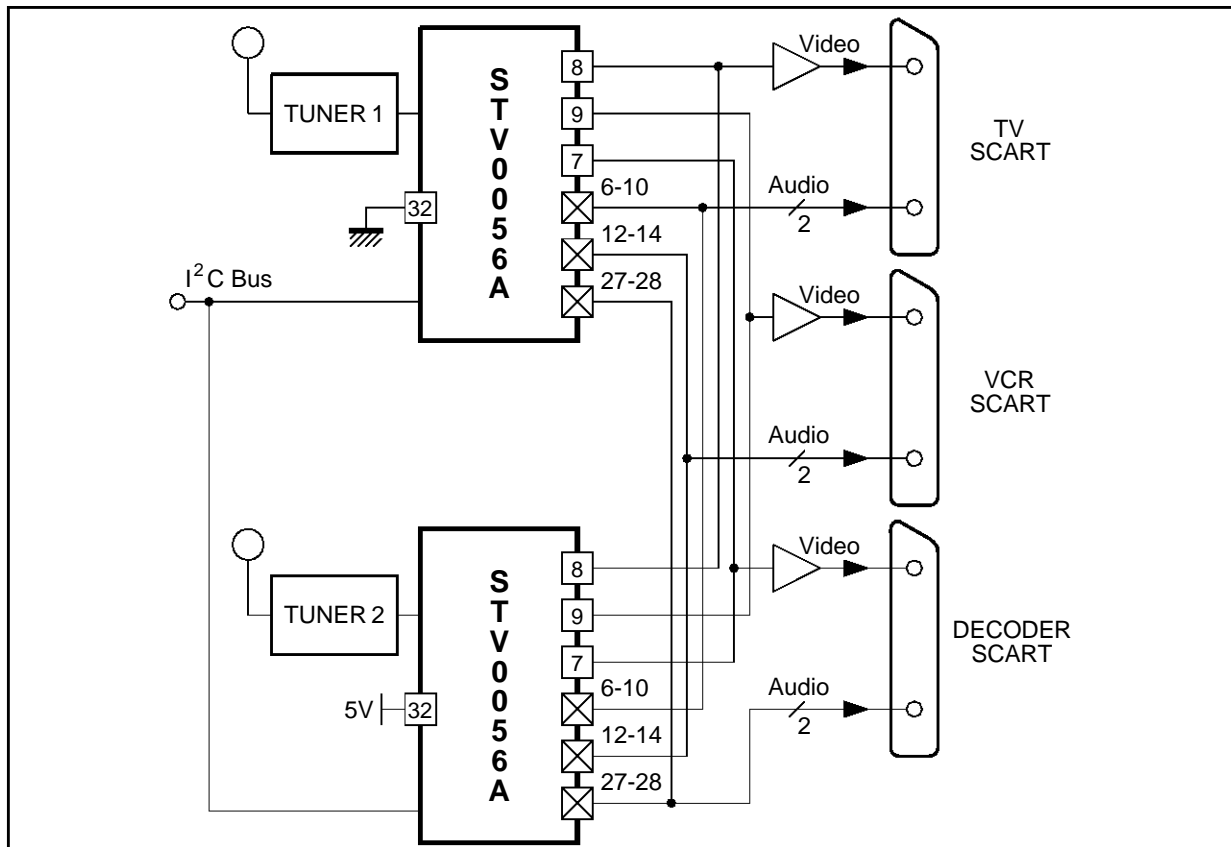

STV0056A

PACKAGE MECHANICAL DATA

56 PINS - PLASTIC SHRINK DIP

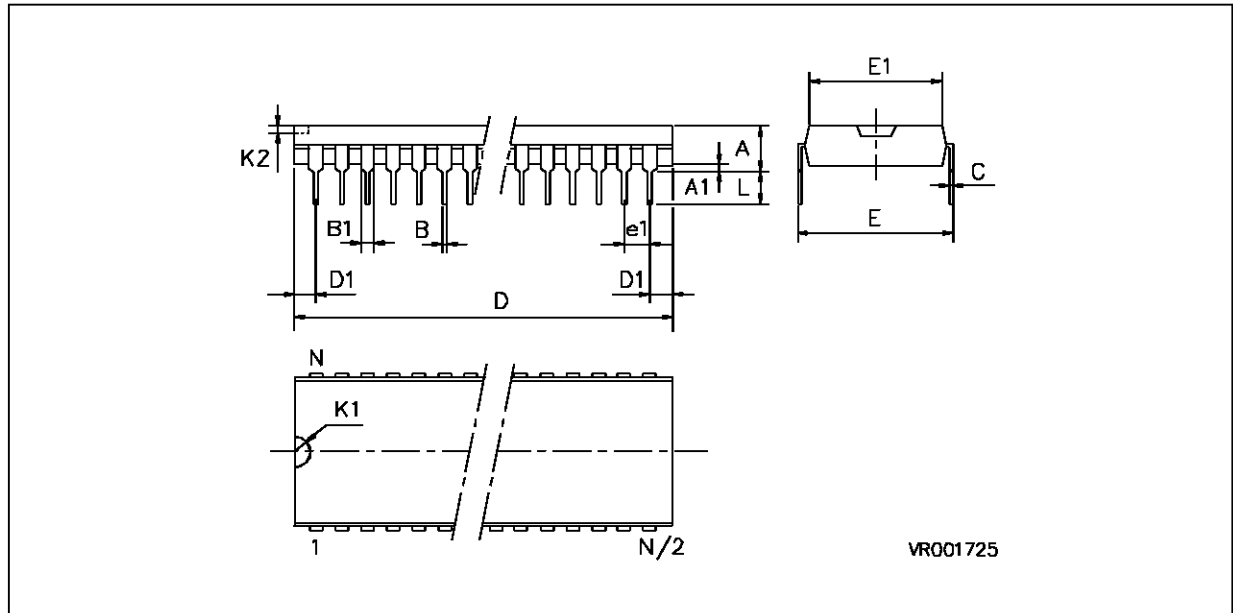

Dim.	mm			inches		
	Min	Typ	Max	Min	Typ	Max
A			5.08			0.200
A1	0.51			0.020		
B	0.35		0.59	0.014		0.023
B1	0.75		1.42	0.030		0.056
C	0.20		0.36	0.008		0.014
D		52.12			2.052	
D1	-	-	-	-	-	-
E			18.54			0.730
E1		13.72				0.540
K1	-	-	-	-	-	-
K2	-	-	-	-	-	-
L	2.54		3.81	.100		0.150
e1		1.78			0.070	
Number of Pins						
N	56					

Information furnished is believed to be accurate and reliable. However, SGS-THOMSON Microelectronics assumes no responsibility for the consequences of use of such information nor for any infringement of patents or other rights of third parties which may result from its use. No licence is granted by implication or otherwise under any patent or patent rights of SGS-THOMSON Microelectronics. Specifications mentioned in this publication are subject to change without notice. This publication supersedes and replaces all information previously supplied. SGS-THOMSON Microelectronics products are not authorized for use as critical components in life support devices or systems without express written approval of SGS-THOMSON Microelectronics.

© 1996 SGS-THOMSON Microelectronics - All Rights Reserved

Purchase of μ C Components of SGS-THOMSON Microelectronics, conveys a license under the Philips μ C Patent. Rights to use these components in a μ C system, is granted provided that the system conforms to the μ C Standard Specifications as defined by Philips.

SGS-THOMSON Microelectronics GROUP OF COMPANIES

Australia - Brazil - Canada - China - France - Germany - Hong Kong - Italy - Japan - Korea - Malaysia - Malta - Morocco
The Netherlands - Singapore - Spain - Sweden - Switzerland - Taiwan - Thailand - United Kingdom - U.S.A.