

SLES028A – MAY 2002 – REVISED SEPTEMBER 2002

## TRUE DIGITAL AUDIO AMPLIFIER TAS5110 PWM POWER OUTPUT STAGE

### FEATURES

- 50-W RMS Power Into 6  $\Omega$  at 10% THD
- 40-W RMS Power Into 6  $\Omega$  at 0.1% THD
- THD+N < 0.09% Typical (1-kHz Input Signal)
- 93-dB Dynamic Range (TDAA System)
- Power Efficiency > 90% Into 6- $\Omega$  and 8- $\Omega$  Load
- Low Profile, SMD 32-Pin PowerPAD™ Package
- Self-Protecting Design
- 3.3-V Digital Interface
- EMI Compliant When Used With Recommended System Design

### APPLICATIONS

- DVD Receiver
- Home Theater
- Mini/Micro Component Systems
- Internet Music Appliance
- Car Audio Amplifiers and Head Units

### DESCRIPTION

The TAS5110 is a high-performance true digital audio amplifier (TDAA) power stage, designed to drive 50 W per channel. The TAS5110 incorporates TI's equibit™ technology and is used in conjunction with a digital audio PWM processor (TAS50xx) to deliver high-power, true digital audio amplification. The efficiency of this digital amplifier can be greater than 90%, reducing the size of both the power supplies and heat sinks needed. The TAS5110 accepts a mono PWM 3.3-V input and controls the switching of an internal CMOS H-bridge.

When used with the TAS50xx PWM processor, system performance of less than 0.09% THD is attainable. Over-current protection, over-temperature, and under-voltage protections are built into the TAS5110, safeguarding the H-bridge and speakers against output shorts, over-voltage conditions, and other fault conditions that could damage the system.

### TYPICAL TDAA STEREO AUDIO SYSTEM

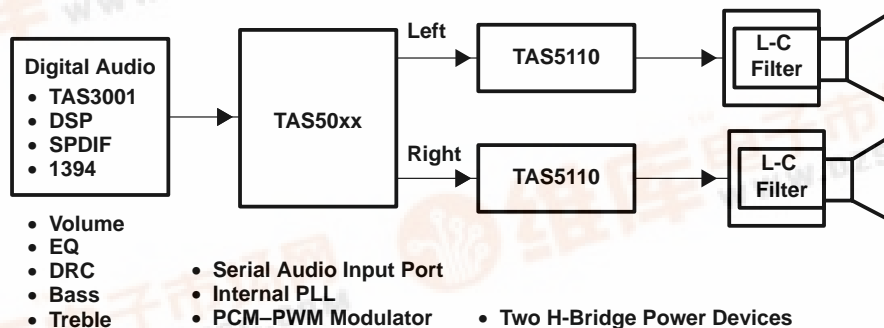

Please be aware that an important notice concerning availability, standard warranty, and use in critical applications of Texas Instruments semiconductor products and disclaimers thereto appears at the end of this data sheet.

PowerPAD and Equibit are trademarks of Texas Instruments.

PRODUCTION DATA information is current as of publication date. Products conform to specifications per the terms of Texas Instruments standard warranty. Production processing does not necessarily include testing of all parameters.

Copyright © 2002, Texas Instruments Incorporated



# TAS5110

SLES028A – MAY 2002 – REVISED SEPTEMBER 2002

## terminal assignments

The TAS5110 is offered in a thermally enhanced 32-pin HTSSOP surface-mount package (DAP). The DAP package has the PowerPAD on the bottom.

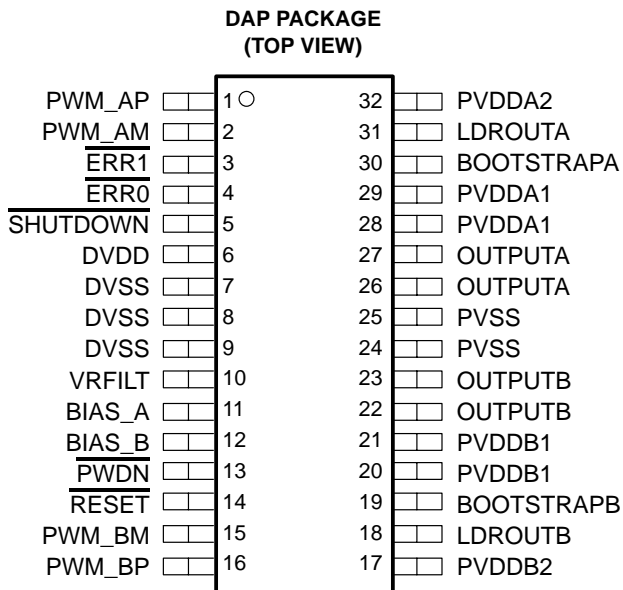

## ordering information

T <sub>C</sub>	PACKAGE	TAPE AND REEL
0°C to 70°C	TAS5110DAP	TAS5110DAPR
-40°C to 85°C	TAS5110IDAP	TAS5110IDAPR

## terminal assignments

In addition to the 32-pin HTSSOP DAP package, the TAS5110 is offered in a thermally enhanced 32-pin TSSOP surface-mount package (DAD). The DAD package has the PowerPAD on top.

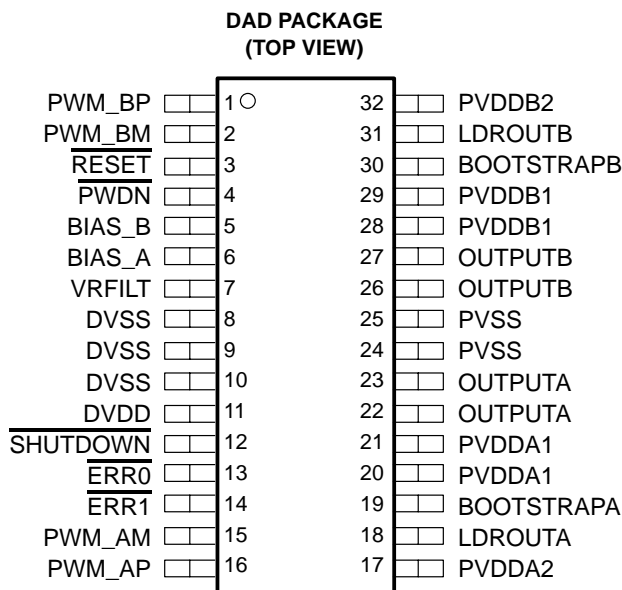

## ordering information

T <sub>C</sub>	PACKAGE	TAPE AND REEL
0°C to 70°C	TAS5110DAD	TAS5110DADR
-40°C to 85°C	TAS5110IDAD	TAS5110IDADR

## references

*TAS5000 Digital Audio PWM Processor* data manual – TI Literature Number SLAS270

*TAS5001 Digital Audio PWM Processor* data manual – TI Literature Number SLES009

*TAS5010 Digital Audio PWM Processor* data manual – TI Literature Number SLAS328

*TAS5012 Digital Audio PWM Processor* data manual – TI Literature Number SLES006

*Digital Audio Measurements* – TI literature number SLAA114

*PowerPAD Thermally Enhanced Package* – TI literature number SLMA002

# TAS5110

SLES028A – MAY 2002 – REVISED SEPTEMBER 2002

## functional block diagram

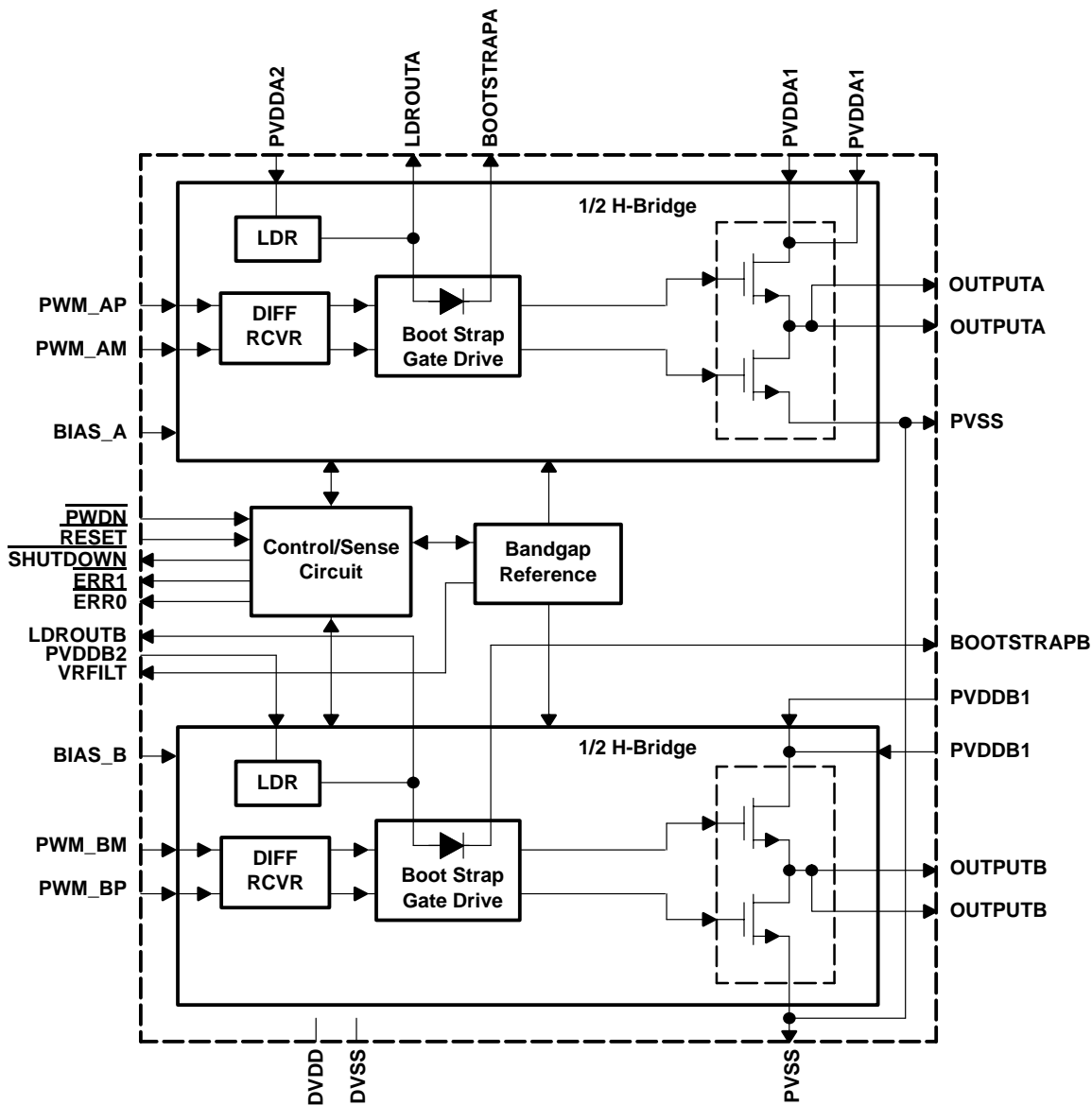

suggested system block diagrams

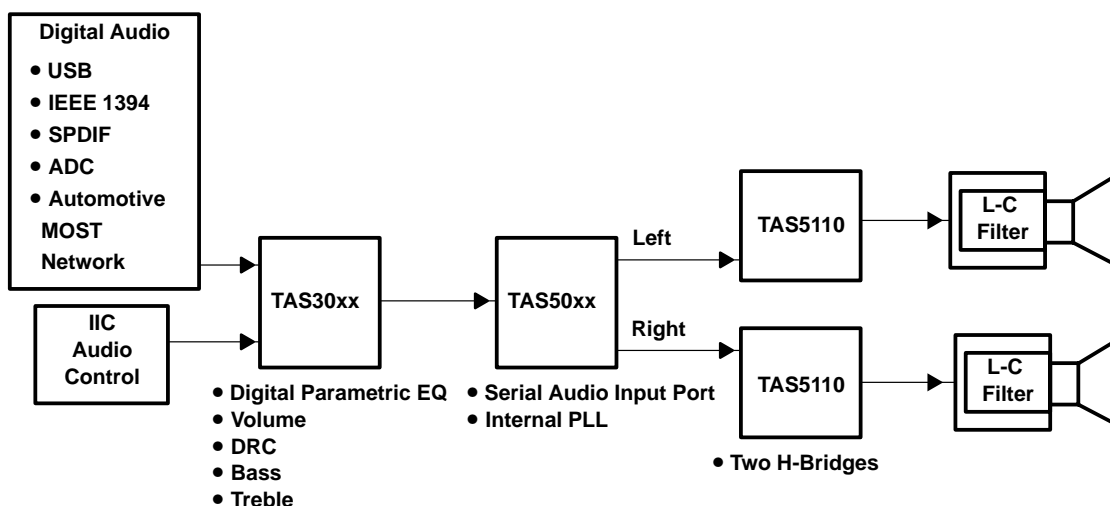

Figure 1. System #1: Stereo Configuration With a TAS3001 Digital Audio Processor

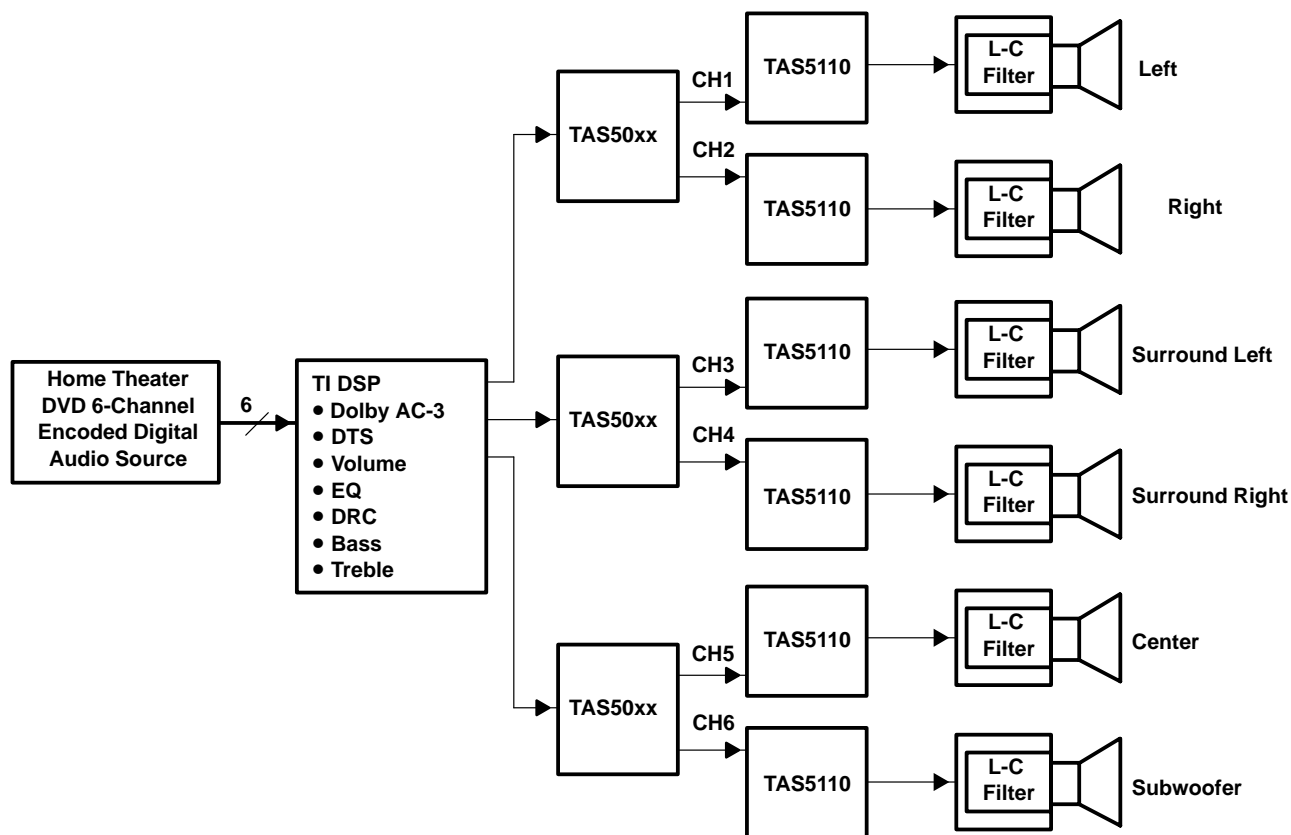

Figure 2. System #3: 6-Channel Audio Playback

# TAS5110

SLES028A – MAY 2002 – REVISED SEPTEMBER 2002

## Terminal Functions

TERMINAL			I/O	DESCRIPTION
NAME	DAP NO.	DAD NO.		
BIAS_A	11	6	I	Connect external resistor to DVSS.
BIAS_B	12	5	I	Connect external resistor to DVSS.
BOOTSTRAPA	30	19	O	Bootstrap capacitor pin for H-bridge A
BOOTSTRAPB	19	30	O	Bootstrap capacitor pin for H-bridge B
DVDD	6	11	I	3.3-V digital voltage supply for logic
DVSS	7, 8, 9	8, 9, 10	I	Digital ground for logic is internally connected to PVSS. All three pins must be tied together but not connected externally to PVSS. See Figure 5.
ERR1	3	14	O	Error/warning report indicator. This output is open drain with internal pullup resistor.
ERR0	4	13	O	Error/warning report indicator. This output is open drain with internal pullup resistor.
LDROUTA	31	18	O	Low voltage drop-out regulator output A (not to be used to supply current to external circuitry)
LDROUTB	18	31	O	Low voltage drop-out regulator output B (not to be used to supply current to external circuitry)
OUTPUTA	26, 27	22, 23	O	H-bridge output A
OUTPUTB	22, 23	26, 27	O	H-bridge output B
PVDDA1	28, 29	20, 21	I	High voltage power supply, H-bridge A
PVDDA2	32	17	I	High voltage power supply for low-dropout voltage regulator A-side
PVddb1	20, 21	28, 29	I	High voltage power supply, H-bridge B
PVddb2	17	32	I	High voltage power supply for low-dropout voltage regulator B-side
PVSS	24, 25	24, 25	I	High voltage power supply ground
PWDN	13	4	I	Power down = 0, normal mode = 1
PWM_AM	2	15	I	PWM input A(-)
PWM_AP	1	16	I	PWM input A(+)
PWM_BP	16	1	I	PWM input B(+)
PWM_BM	15	2	I	PWM input B(-)
RESET	14	3	I	Reset and mute mode = 0, normal mode = 1, when in reset mode, H-bridge MOSFETs are in low-low output state. Asserting the RESET signal low causes all fault conditions to be cleared.
SHUTDOWN	5	12	O	Device is in shutdown due to fault condition, normal mode = 1, shutdown = 0, when device is in shutdown mode the H-bridge MOSFETs are in low-low output state. The latched output can be cleared by asserting the RESET signal. This output is open drain with internal pullup resistor.
VERFILT	10	7	O	A filter capacitor must be added between VERFILT and DVSS pins.

NOTE: The four PWM inputs: PWM\_AP, PWM\_AM, PWM\_BP, and PWM\_BM must always be connected to the TAS50xx output pins, and never left floating. Floating PWM input pins causes an illegal PWM input state signal to be asserted.

Dual pins: OUTPUTA, OUTPUTB, PVDDA1, and PVddb1 must have both pins connected externally to the same point on the circuit board, respectively. Both PVSS pins must also be connected together externally. These multiple pins are for the high-current DMOS output devices. Failure to connect all the multiple pins to the same respective node results in excessive current flow in the internal bond wires and can cause the device to fail. All electrical characteristics are specified and measured with all of the multiple pins connected to the same node, respectively.

## functional description

### PWM H-bridge state control

The digital interface control signals consists of PWM\_AP, PWM\_AM, PWM\_BP, and PWM\_BM. These signals are a complementary differential signal format for the A-side half-bridge and the B-side half-bridge.

### bootstrapped gate drive

The TAS5110 includes two dedicated bootstrapped power supplies. A bootstrap capacitor is connected between the individual bootstrap pin and the associated output. For example, a capacitor is connected between the BOOTSTRAPA pin and OUTPUTA pin, and another capacitor is connected between the BOOTSTRAPB pin and the OUTPUTB pin. The bootstrap power supply minimizes the number of high voltage power supply levels externally supplied to the system while providing a low-noise supply level for driving the high-side N-channel DMOS transistors.

### low-dropout voltage regulator

Two on-chip low-dropout voltage regulators (LDO) are provided to minimize the number of external power supplies needed for the system. These voltage regulators are for internal circuits only and cannot be used for external circuitry. Each LDO is dedicated to a half-bridge and its gate driver. An LDO output capacitor is connected between the individual LDO output pin and the associated output return. For example, a capacitor is connected between the LDROUTA pin and PVSS pin, and another capacitor is connected between the LDROUTB pin and PVSS pin.

### high-current H-bridge output stage

The positive outputs of the H-bridge are the two OUTPUTA pins. The negative outputs of the H-bridge are the two OUTPUTB pins. The logic for the input command to H-bridge outputs is described in the H-bridge output mapping section below. When the TAS5110 is in the normal mode, as seen in the H-bridge output mapping tables, the outputs are decoded from the inputs. However, the TAS5110 is immediately shut down if any of the following error conditions occur: over-current, over-temperature, low regulator output voltage, or an illegal PWM input state is applied. For these conditions, the outputs are set to the appropriate disabled state as specified in the H-bridge output mapping section, and the SHUTDOWN pin is set low.

### H-bridge output mapping

The A-side half-bridge output is designed to the following truth table:

INPUTS				OUTPUTS		DESCRIPTION
RESET	PWDN	PWM_AP	PWM_AM	SHUTDOWN	OUTPUTA	
X	X	X	X	0	0 or Hi-Z <sup>†</sup>	Shutdown
X	0	X	X	1	Hi-Z	Powerdown
0	1	X	X	1	0	Reset
1	1	0	0	0	0	Shutdown
1	1	0	1	1	0	Normal
1	1	1	0	1	1	Normal
1	1	1	1	0	0	Shutdown

<sup>†</sup> Output is 0 for low voltage, over temperature, and illegal input. Hi-Z is for over current.

# TAS5110

SLES028A – MAY 2002 – REVISED SEPTEMBER 2002

## H-bridge output mapping (continued)

The B-side half-bridge output is designed to the following truth table:

INPUTS				OUTPUTS		DESCRIPTION
RESET	PWDN	PWM_BP	PWM_BM	SHUTDOWN	OUTPUTB	
X	X	X	X	0	0 or Hi-Z†	Shutdown
X	0	X	X	1	Hi-Z	Powerdown
0	1	X	X	1	0	Reset
1	1	0	0	0	0	Shutdown
1	1	0	1	1	0	Normal
1	1	1	0	1	1	Normal
1	1	1	1	0	0	Shutdown

† Output is 0 for low voltage, over temperature, or illegal input. Hi-Z is for over current.

## control/sense circuitry

The control/sense circuitry consists of the following 3.3-V logic level pins:  $\overline{\text{PWDN}}$ ,  $\overline{\text{RESET}}$ ,  $\overline{\text{ERR0}}$ ,  $\overline{\text{ERR1}}$ , and  $\overline{\text{SHUTDOWN}}$ . The active-low  $\overline{\text{PWDN}}$  input pin powers down all internal circuitry and forces the H-bridge outputs to the Hi-Z state. When the  $\overline{\text{PWDN}}$  pin is low, the open drain  $\overline{\text{ERR0}}$ ,  $\overline{\text{ERR1}}$ , and  $\overline{\text{SHUTDOWN}}$  pins are also disabled so that their outputs can be pulled high. The active-low  $\overline{\text{RESET}}$  input pin forces the H-bridge outputs to the low-low state and resets the over-current shutdown latch. The  $\overline{\text{PWDN}}$  pin overrides the  $\overline{\text{RESET}}$  pin. The  $\overline{\text{ERR0}}$ ,  $\overline{\text{ERR1}}$ , and  $\overline{\text{SHUTDOWN}}$  outputs indicate the following conditions in the TAS5110 as shown in the table below. These three outputs are open-drain connections with internal pullup resistors so that wire-ORed connections can be made by the user with other external control devices. The short-circuit protect error condition latches the TAS5110 in this shutdown state and forces the H-bridge outputs to the Hi-Z state until the device is reset by means of the  $\overline{\text{RESET}}$  pin. The illegal PWM input state, over-temperature, and low regulator voltage error conditions does not latch the device in the shutdown condition. Instead the H-bridge outputs are forced to the low-low state and the TAS5110 returns to normal operation as soon as the error condition ends. Loss of clocking PWM signal is also considered an illegal PWM input state.

SHUTDOWN	ERR1	ERR0	FUNCTION	OUTPUTA	OUTPUTB
0	0	0	Illegal PWM input state	Low	Low
0	0	1	Short circuit protect (latch)	Hi-Z	Hi-Z
0	1	0	Over temperature protect	Low	Low
0	1	1	Low regulator voltage protect	Low	Low
1	0	0	Reserved	—	—
1	0	1	Reserved	—	—
1	1	0	High temperature – warning	Normal	Normal
1	1	1	Normal operation	Normal	Normal

## device operation

### power sequences

#### system power-up/power-down sequencing

The recommended power-up/power-down sequence is shown in Figure 3. For proper operation the  $\overline{\text{RESET}}$  signal should be kept low when both DVDD and output power (PVDDA1, PVDDA2, PVDDB1, and PVDDB2) are being applied. The  $\overline{\text{RESET}}$  signal should remain low for at least 1 ms after output power is applied.

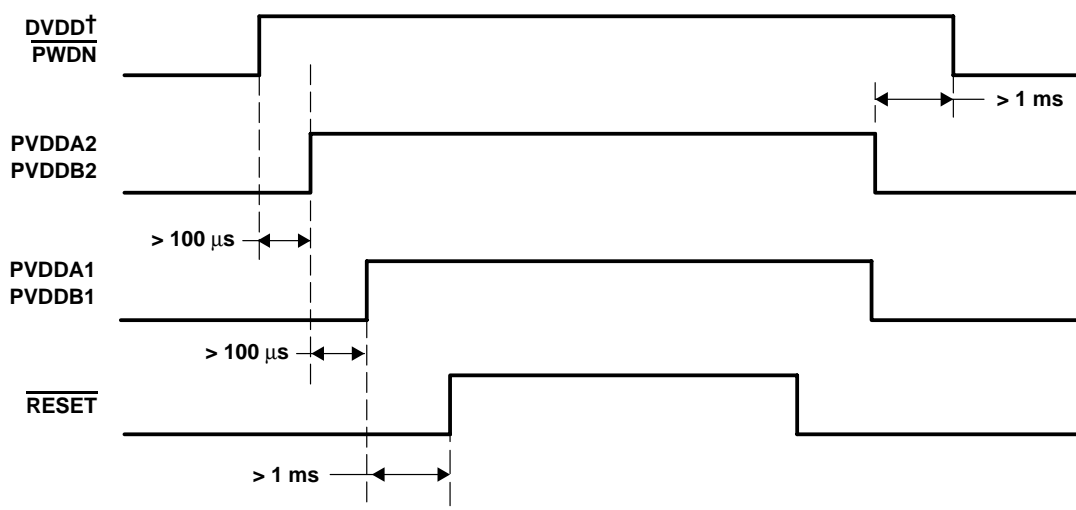

† For most applications, it is recommended that the  $\overline{\text{PWN}}$  pin be connected directly to the DVDD pin.

**Figure 3. Power-Up/Power-Down Sequence**

#### $\overline{\text{RESET}}$ function

The device is put into a reset condition when the (active low)  $\overline{\text{RESET}}$  signal is asserted. While in the reset state, the input H-bridge control signals consisting of PWM\_AP, PWM\_AM, PWM\_BP, and PWM\_BM are ignored, and the H-bridge MOSFETs are placed in a state where OUTPUTA and OUTPUTB are both low. Asserting the  $\overline{\text{RESET}}$  signal low also causes the short circuit protection latch to be reset. The  $\overline{\text{RESET}}$  signal is normally connected to the VALID signal from the TAS50xx.

#### reinitialization sequence

Proper initial conditions for this device include asserting the  $\overline{\text{RESET}}$  signal until the reset operation has completed (1 ms). Additionally, when using this device with the TAS50xx controller, this function can be accomplished by asserting the reset pin on the TAS50xx during the reset sequence (see Figure 3).

#### audio application considerations

##### optimal power transfer for H-bridge

The TAS5110 is a power H-bridge that is designed to deliver a maximum of 50 W RMS into a 6- $\Omega$  load. In order to achieve 50 W into 6  $\Omega$ , the system designer must provide an adequate thermal design. See the *Thermal Methodology for the 32-Pin DAD Package 50 W, 6- $\Omega$  Test* and the *Thermal Methodology for the 32-Pin DAP Package 50 W, 6- $\Omega$  Test* sections for a discussion of possible thermal solutions. Careful attention must be given to the value of the high-voltage power supply level for a given load resistance. See recommended operating conditions. See the *Maximum Available Power at Common Load Impedances for Both DAP and DAD Packages* section.

# TAS5110

SLES028A – MAY 2002 – REVISED SEPTEMBER 2002

---

## audio application considerations (continued)

### reconstruction output filter

An output reconstruction filter is required between the H-bridge outputs and the loudspeaker load. This second order low-pass filter passes the audio information to the loudspeaker, while filtering out the high frequency out-of-band information contained in the H-bridge output PWM pulses. The values of the L and C components selected are dependent on the loudspeaker load impedance.

### fault indicator usage

The TAS5110 is a self-protecting device that provides device fault reporting, including over-temperature protect, under-voltage lockout (low-regulator voltage), and short circuit protection. The short circuit protection protects against short circuits that may occur at the loudspeaker load when configured. The TAS5110 is not recommended for driving loads less than 6  $\Omega$ , since the internal current limit protection might be activated.

An under-voltage lockout signal occurs when an insufficient voltage level is present on the LDROUTA or LDROUTB pins. During this condition gate drive levels are not sufficient for driving the power MOSFETs. Normal operation is resumed when the minimum proper LDROUTA or LDROUTB level is obtained and the low regulator voltage protect signal is de-asserted. See the *control/sense circuitry* section for error and warning conditions.

A high temperature warning signal is asserted on pin  $\overline{\text{ERR0}}$  when the device temperature exceeds 125°C typical.

If the internal device temperature exceeds 150°C typical, the over temperature protect signal is asserted and the TAS5110 is shut down. The device re-enables once the temperature drops to 125°C typical. See the *control/sense circuitry* section for error and warning conditions.

Detection of an illegal PWM input state or the loss of a clocking PWM input signal causes an illegal PWM input state signal to be asserted on the  $\overline{\text{ERR1}}$  and  $\overline{\text{ERR0}}$  pins and sets the  $\overline{\text{SHUTDOWN}}$  pin to the low state.

## absolute maximum ratings over operating free-air temperature (unless otherwise noted)†

DC supply voltage range: DVDD to DVSS .....	-0.3 V to 4.2 V
PWM_AP, PWM_AM, PWM_BP, PWM_BM .....	-0.3 V to DVDD + 0.3 V
$\overline{\text{RESET}}$ , $\overline{\text{PWDN}}$ .....	-0.3 V to DVDD + 0.3 V
PVDDA1 to PVSS, PVddb1 to PVSS .....	-0.3 V to 28 V
PVDDA2 to PVSS, PVddb2 to PVSS .....	-0.3 V to 27 V
Output DMOS drain-to-source breakdown voltage .....	28 V
Operating junction temperature range, $T_J$ .....	-40°C to 150°C
Storage temperature range, $T_{\text{stg}}$ .....	-65°C to 150°C
Lead temperature 1,6 mm (1/16 inch) from case for 10 seconds) .....	260°C

† Stresses beyond those listed under “absolute maximum ratings” may cause permanent damage to the device. These are stress ratings only, and functional operation of the device at these or any other conditions beyond those indicated under “recommended operating conditions” is not implied. Exposure to absolute-maximum-rated conditions for extended periods may affect device reliability.

**recommended operating conditions (maximum output power = 50 W (RMS),  $T_J = 25^\circ\text{C}$ )****thermal data†**

PARAMETER		MIN	NOM	MAX	UNIT
Shutdown junction temperature, $T_{J(SD)}$			150		$^\circ\text{C}$
Warning junction temperature, $T_{J(W)}$			125		$^\circ\text{C}$
Operating temperature, $T_C$	Commercial	0	25	70	$^\circ\text{C}$
	Industrial	-40	25	85	$^\circ\text{C}$
Thermal resistance junction-to-case, $\theta_{JC}^\ddagger$			1.6		$^\circ\text{C/W}$
Thermal resistance junction-to-ambient, $\theta_{JA}^\ddagger$		2 oz. trace and copper pad without solder		44.3	$^\circ\text{C/W}$

† One of the most influential components on the thermal performance of a package is board design. In order to take full advantage of the heat dissipating abilities of the PowerPAD packages, a board must be used that acts similar to a heat sink and allows for the use of the exposed (and solderable), deep downset pad. See Appendix A of the *PowerPAD Thermally Enhanced Package* application note, TI literature number SLMA002.

‡ For both DAD and DAP packages.

 **$R_L = 6\ \Omega$  to  $8\ \Omega$** 

PARAMETER			MIN	NOM	MAX	UNIT
Supply voltage	Digital	DVDD to DVSS	3	3.3	3.6	V
	Regulator	PVDDA2 to PVSS	16.5	22	26.5	V
		PVddb2 to PVSS	16.5	22	26.5	
		PVDDA2 to PVSS $^\S$	10.5		16.5	
		PVddb2 to PVSS $^\S$	10.5		16.5	

$^\S$  Connect LDROUTA to PVDDA2 and connect LDROUTB to PVddb2. Under this condition, the H-bridge forward on-state resistance is increased. This increases internal power dissipation. Maximum output power may need to be reduced to meet thermal conditions.

**maximum available power at common load impedances for both DAP and DAD packages unclipped (0 dB level, test conditions described in the *Thermal Methodology for the 32-Pin DAD Package 50 W, 6- $\Omega$  Test* and *Thermal Methodology for the 32-Pin DAP Package 50 W, 6- $\Omega$  Test* sections**

LOAD IMPEDANCE ( $\Omega$ )	PVDDA1/PVddb1 (VDC)	APPROXIMATE MAX OUTPUT POWER (W)	THD+N AT MAX POWER AND 1 kHz INPUT $^\parallel$
6	27	50	< 10%
6	27	43	< 0.09%
8	27	34	< 0.09%

$^\parallel$  Dependent on board design and component selection.

**static digital specifications**

**$\overline{\text{RESET}}$ ,  $\overline{\text{PWDN}}$ ,  $\text{PWM\_AP}$ ,  $\text{PWM\_AM}$ ,  $\text{PWM\_BP}$ ,  $\text{PWM\_BM}$ ,  $T_J = 25^\circ\text{C}$ ,  $\text{DVDD} = 3.3\ \text{V}$**

PARAMETERS	MIN	MAX	UNIT
High-level input voltage, $V_{IH}$	2		V
Low-level input voltage, $V_{IL}$		0.8	V
Input leakage current	-10	10	$\mu\text{A}$

**$\overline{\text{ERR0}}$ ,  $\overline{\text{ERR1}}$ ,  $\overline{\text{SHUTDOWN}}$ , (open drain with internal pullup resistor)  $T_J = 25^\circ\text{C}$ ,  $\text{DVDD} = 3.3\ \text{V}$**

PARAMETERS	MIN	MAX	UNIT
Internal pullup resistors from $\overline{\text{SHUTDOWN}}$ , $\overline{\text{ERR0}}$ , $\overline{\text{ERR1}}$ to DVDD	15		$\text{k}\Omega$
Low-level output voltage ( $I_O = 4\ \text{mA}$ ), $V_{OL}$		0.4	V

# TAS5110

SLES028A – MAY 2002 – REVISED SEPTEMBER 2002

## electrical characteristics

supply,  $T_J = 25^\circ\text{C}$  ( $F_{\text{switching}} = 384\text{ kHz}$ , OUTPUTA and OUTPUTB not connected, DVDD = 3.3 V, PVDDA1 = 25 V, PVDDB1 = 25 V, PVDDA2 = 22 V, PVDDB2 = 22 V, 50% input duty cycle)

PARAMETER		TYP	MAX	UNIT
Supply current	DVDD	Operating	2	mA
		$\overline{\text{PWN}} = 0$	500	$\mu\text{A}$
	PVDDA1 PVDDB1	Operating†	6.3	mA
		$\overline{\text{PWN}} = 0$	25	$\mu\text{A}$
	PVDDA2 PVDDB2	Operating	6.5	mA
		$\overline{\text{PWN}} = 0$	250	$\mu\text{A}$

† 13-k $\Omega$  resistor from BIAS\_A (pin 11) to DVSS and 13-k $\Omega$  resistor from BIAS\_B (pin 12) to DVSS.

## H-Bridge transistors, PVDDA2 = PVDDB2 = 22 V, DVDD = 3.3 V, $T_J = 25^\circ\text{C}$ (unless otherwise noted)

PARAMETER	TEST CONDITIONS	MIN	TYP	MAX	UNIT
Drain-to-source breakdown voltage	$I_D = 1\text{ mA}$ , $\overline{\text{PWN}} = 0$ , Hi-Z state	28			V
Forward on-state resistance, low-side drivers OUTPUTA and OUTPUTB to PVSS	$I_{\text{SINK}} = 2.5\text{ A}$ , See Notes 1, 2, and 3, PWM_AP = PWM_BP = 0, PWM_AM = PWM_BM = 1		0.2	0.24	$\Omega$
Forward on-state resistance, high-side drivers PVDDA1 to OUTPUTA, PVDDB1 to OUTPUTB	$I_{\text{SOURCE}} = 2.5\text{ A}$ , See Notes 1, 2, and 4, PWM_AP = PWM_BP = 1, PWM_AM = PWM_BM = 0		0.2	0.24	$\Omega$
On-state resistance matching low-side drivers			98%		
On-state resistance matching high-side drivers			98%		

- NOTES:
- Test time should be < 1 ms to avoid temperature change.
  - These parameters are measured with voltage-sensing contacts separate from the current-carrying contacts.
  - Connect PVDDA2 and PVDDB2 to a 22-V power supply with respect to PVSS. LDROUTA, LDROUTB, BOOTSTRAPA, and BOOTSTRAPB pins open.
  - Connect PVDDA2 to 22-V power supply with respect to PVSS. LDROUTA, LDROUTB, BOOTSTRAPA, and BOOTSTRAPB capacitors are connected respectively. Clock PWM inputs to allow bootstrap capacitors to charge. 93–99% modulation must be used on PWM\_AP, PWM\_AM, PWM\_BP, and PWM\_BM inputs to prevent the activity detector from shutting down the device during this measurement. Note that  $F_{\text{switching}} = 384\text{ kHz}$ .

## electrical characteristics, voltage regulator, $T_J = 25^\circ\text{C}$ (unless otherwise noted)

PARAMETER	TEST CONDITIONS	MIN	TYP	MAX	UNIT
Output voltage (LDROUTA, LDROUTB)	$I_O = 5\text{ mA}$ , See Note 5, PVDDA2 = PVDDB2 = 18 V to 27 V, DVDD = 3.3 V	14.5	15.3	16	V

NOTE 5: These voltage regulators are for internal gate drive circuits only and are not to be used under any circumstances to supply current to external circuitry.

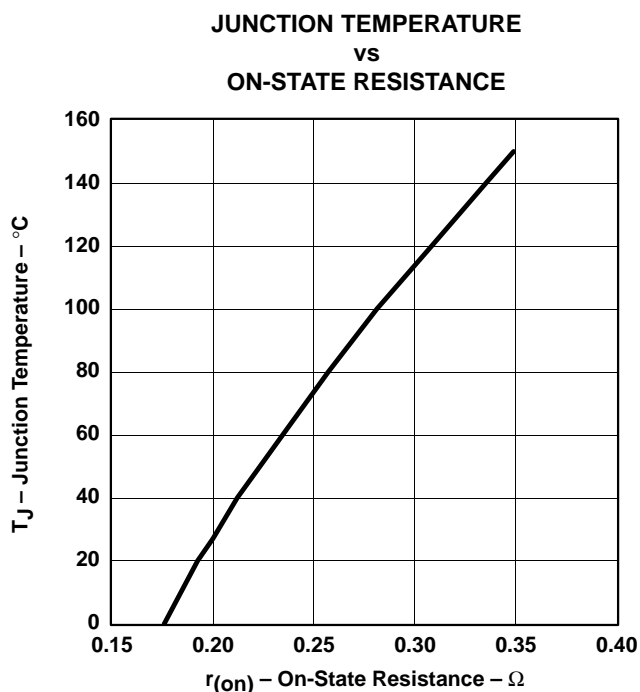

Figure 4. Temperature vs On-State Resistance

**APPLICATION INFORMATION**

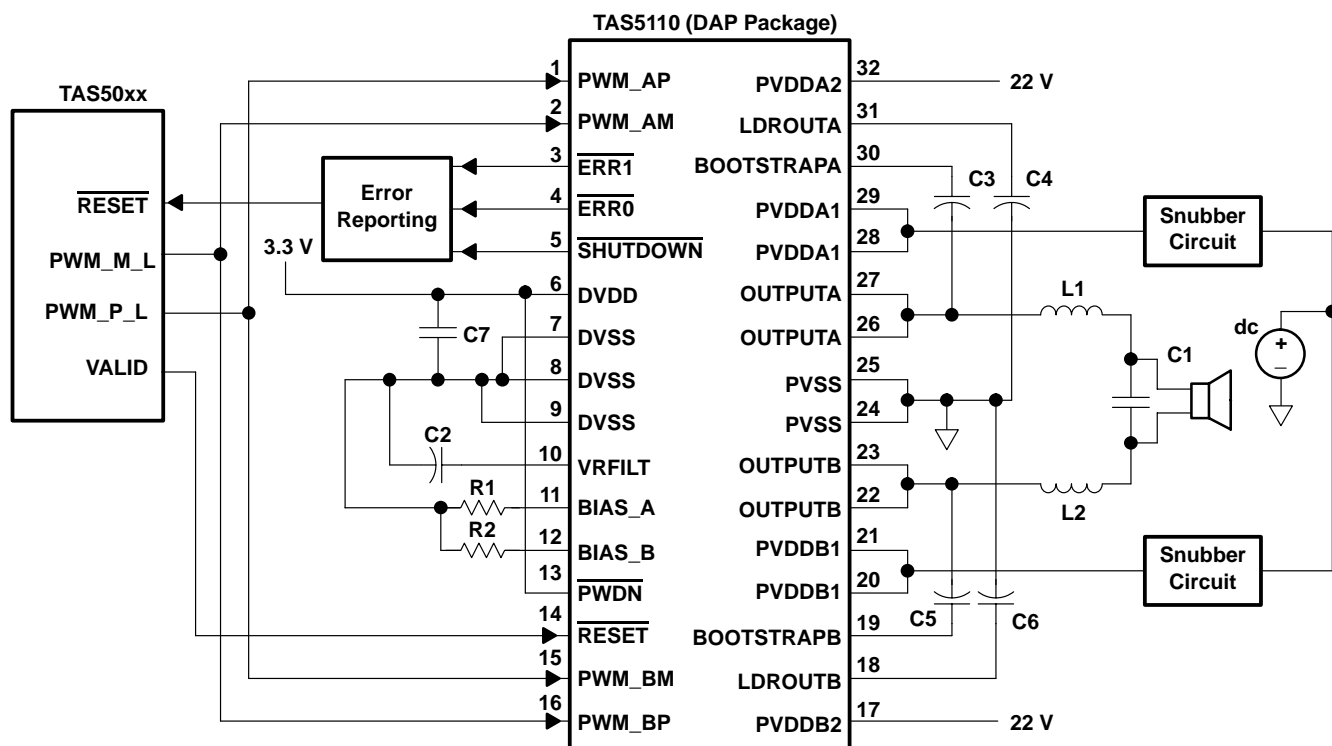

Figure 5. Typical TAS5110 Application (One Channel Shown)

**THERMAL INFORMATION**

The thermally enhanced DAP package is based on the 32-pin HTSSOP, but includes a thermal pad (see Figure 6) to provide an effective thermal contact between the IC and the PCB.

Traditionally, surface mount and power have been mutually exclusive terms. A variety of scaled-down TO-220 type packages have leads formed as gull wings to make them applicable for surface-mount applications. These packages, however, have two shortcomings: they do not address the low profile requirements (<2 mm) of many of today’s advanced systems, and they do not offer a terminal-count high enough to accommodate increasing integration. On the other hand, traditional low-power surface-mount packages require power-dissipation derating that severely limits the usable range of many high-performance analog circuits.

The PowerPAD package (thermally enhanced HTSSOP) combines fine-pitch surface-mount technology with thermal performance comparable to much larger power packages.

The PowerPAD package is designed to optimize the heat transfer to the PCB. Because of the very small size and limited mass of a HTSSOP package, thermal enhancement is achieved by improving the thermal conduction paths that remove heat from the component. The thermal pad is formed using a patented lead-frame design and manufacturing technique to provide a direct connection to the heat-generating IC. When this pad is soldered or otherwise thermally coupled to an external heat dissipater, high power dissipation in the ultrathin, fine-pitch, surface-mount package can be reliably achieved. See the dissipation derating table.

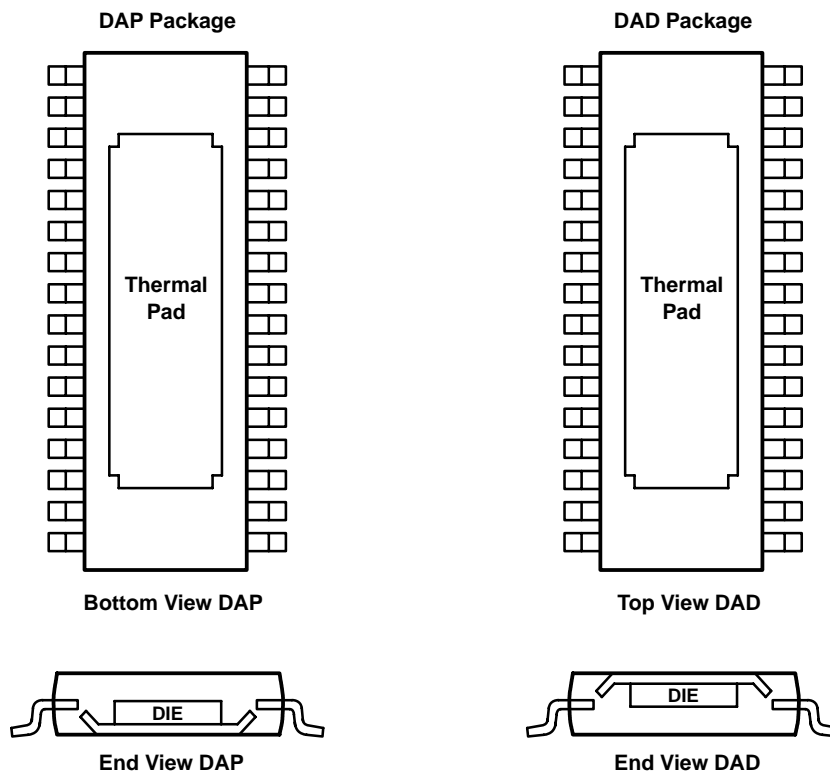

**Figure 6. Views of Thermally Enhanced DAP Package**

### Thermal Methodology for the 32-Pin DAD Package 50 W, 6-Ω Test

The thermal test for the DAD part (e.g., thermal pad oriented away from the board) was conducted as shown in Figure 7 and Figure 8. The cooling approach was to attach a heat sink to the thermal pad and conduct the heat to ambient air.

Since the approach was to use a chassis below the board, it was inverted and a spacer bar used to connect the pads thermally to the heat sink. The bar was made high enough that the components on the board were clear of the chassis.

The pad-to-spacer thermal resistance was about  $3.2^{\circ}\text{C}/\text{W}$  with the thermal compound indicated.

The chassis provided the only heat sink to air and was chosen as representative of a possible cooling approach. A closed plastic top and insulating front and back panels ensured that only the bottom and sides of the U shaped chassis contributed to cooling. The chassis was spaced 0.25 inch from the table to simulate a normal chassis configuration. The thermal pad does not need to be isolated from ground. (Any heat sink with a thermal resistance to air of  $3.9^{\circ}\text{C}/\text{W}$  or lower also works.) In this test, the exposed chassis reached long-term equilibrium temperatures above  $50^{\circ}\text{C}$ , so the approach would have to be modified for touch temperature consideration. The chassis temperature after 10 minutes of 50 W into 6 Ω was below  $50^{\circ}\text{C}$ .

The test ran for three hours with 2 x 50 W RMS at 1 kHz into a 6-Ω resistive load at an ambient lab temperature of  $23^{\circ}\text{C}$ . No audio or thermal problems were encountered during that time.

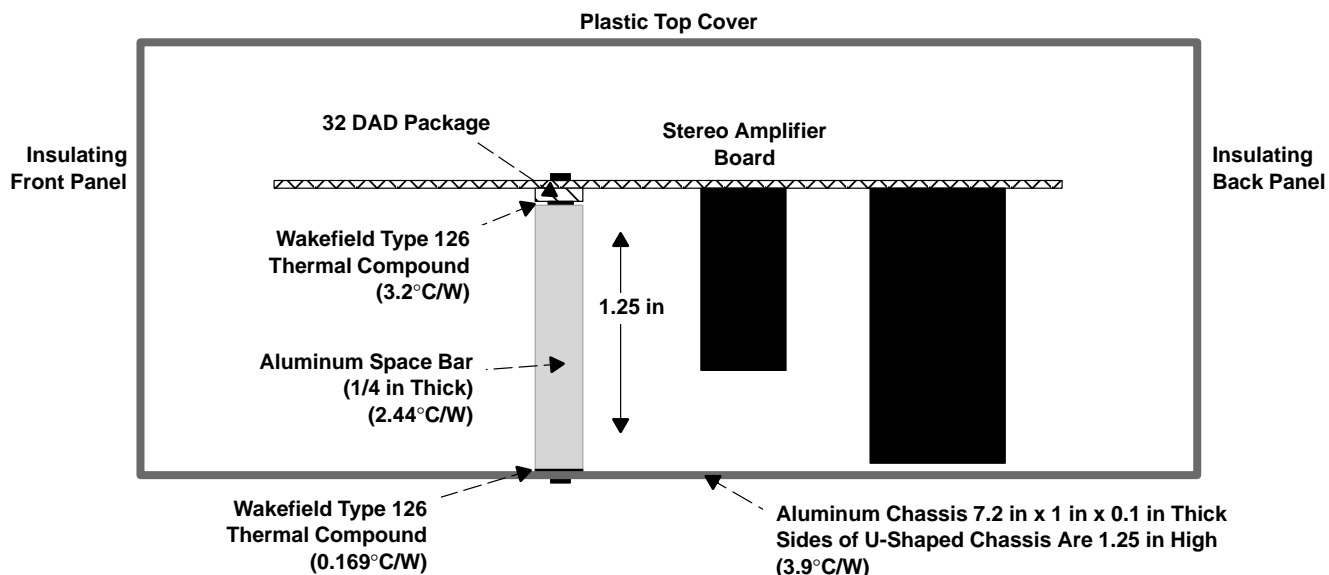

Figure 7. 32-Pin DAD Package Cross-Sectional View (Side)

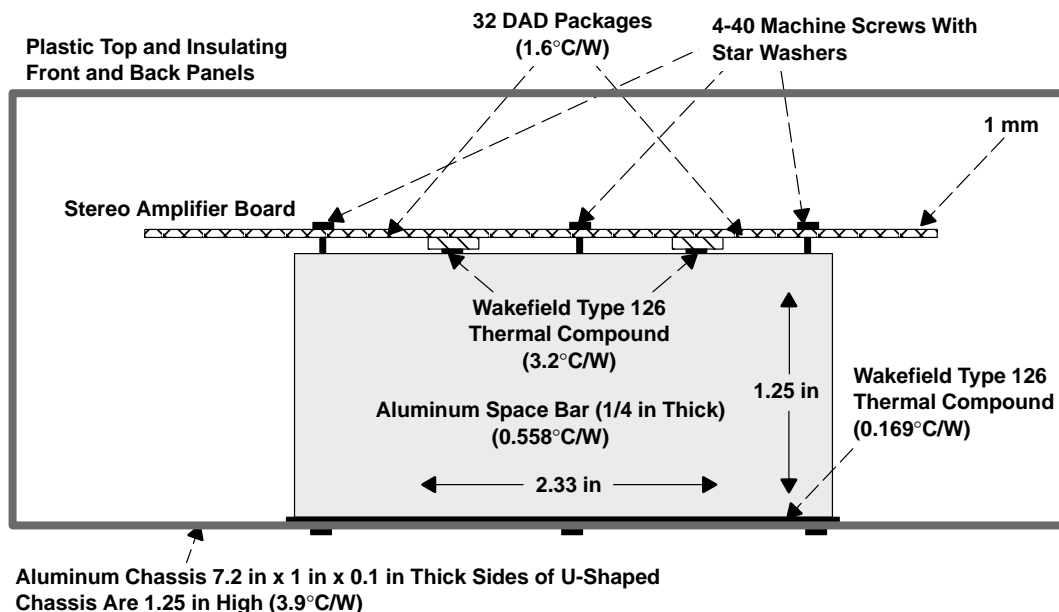

Figure 8. 32-Pin DAD Package Cross-Sectional View (Front)

**Thermal Methodology for the 32-Pin DAP Package 50 W, 6-Ω Test**

The thermal test for the DAP part (e.g., thermal pad soldered to the board) was conducted as shown in Figure 9 and Figure 10. The cooling approach was to conduct the dissipated heat into the via pad on the board, through the vias in the board, and into a heat sink.

The lower via pad area, slightly larger than the IC pad itself, was exposed with a window in the solder resist on the bottom surface of the board. It was not coated with solder during the board construction to maintain a flat surface. In production, this could be accomplished with a peelable solder mask.

A spacer bar was used to keep the through-hole leads from shorting to the chassis. The thermal compound indicated yielded a pad-to-spacer thermal resistance of about 3.2°C/W.

The chassis provided the only heat sink to air and was chosen as representative of a possible cooling approach. A plastic top and insulating front and back panels were used to ensure that only the bottom and sides of the U shaped chassis contributed to cooling. The chassis was spaced 0.25 inch from the table to simulate a normal chassis configuration. (Any heat sink with a thermal resistance to air of 3.9°C/W or lower also works.) In this test, the exposed chassis reached long-term equilibrium temperatures above 50°C, so the approach would have to be modified for touch temperature consideration. The chassis temperature after 10 minutes of 50 W into 6 Ω was below 50°C.

The test ran for three hours with 2 x 50 W RMS at 1 kHz into a 6-Ω resistive load at an ambient lab temperature of 23°C. No audio quality or thermal problems were encountered during that time.

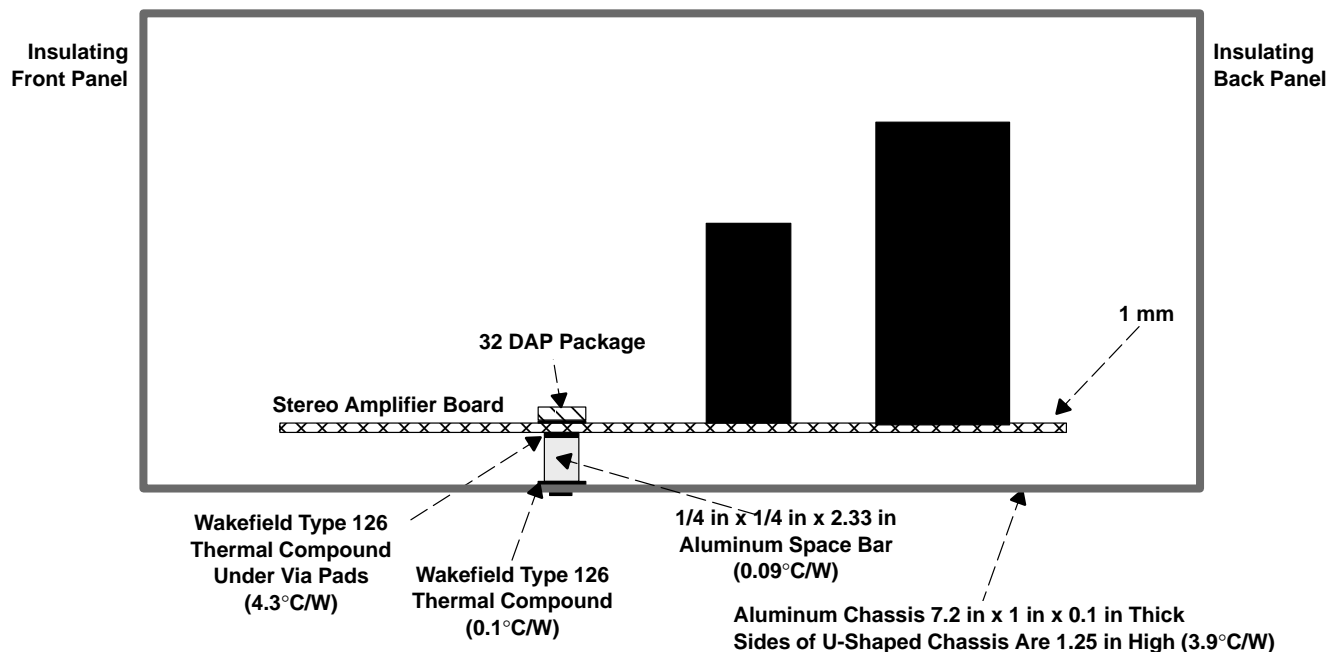

Figure 9. 32-Pin DAP Package Cross-Sectional View (Side)

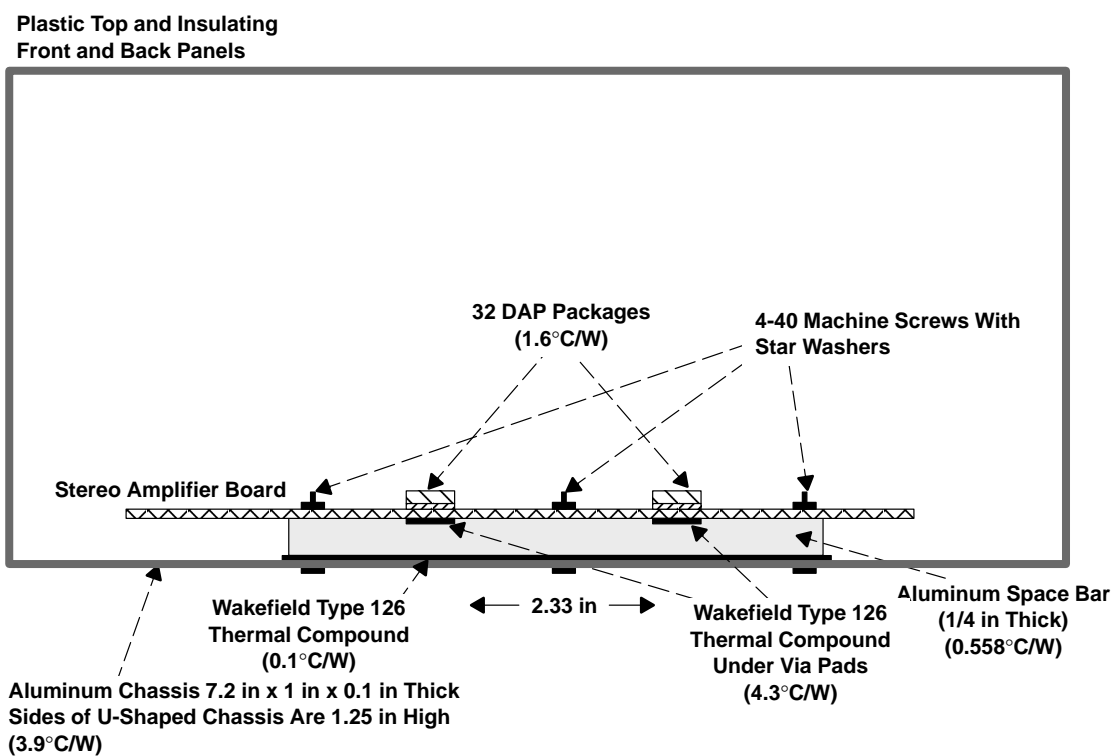

Figure 10. 32-Pin DAP Package Cross-Sectional View (Front)

# TAS5110

SLES028A – MAY 2002 – REVISED SEPTEMBER 2002

## MECHANICAL DATA

DAP (R-PDSO-G\*\*)

PowerPAD™ PLASTIC SMALL-OUTLINE PACKAGE

38 PINS SHOWN

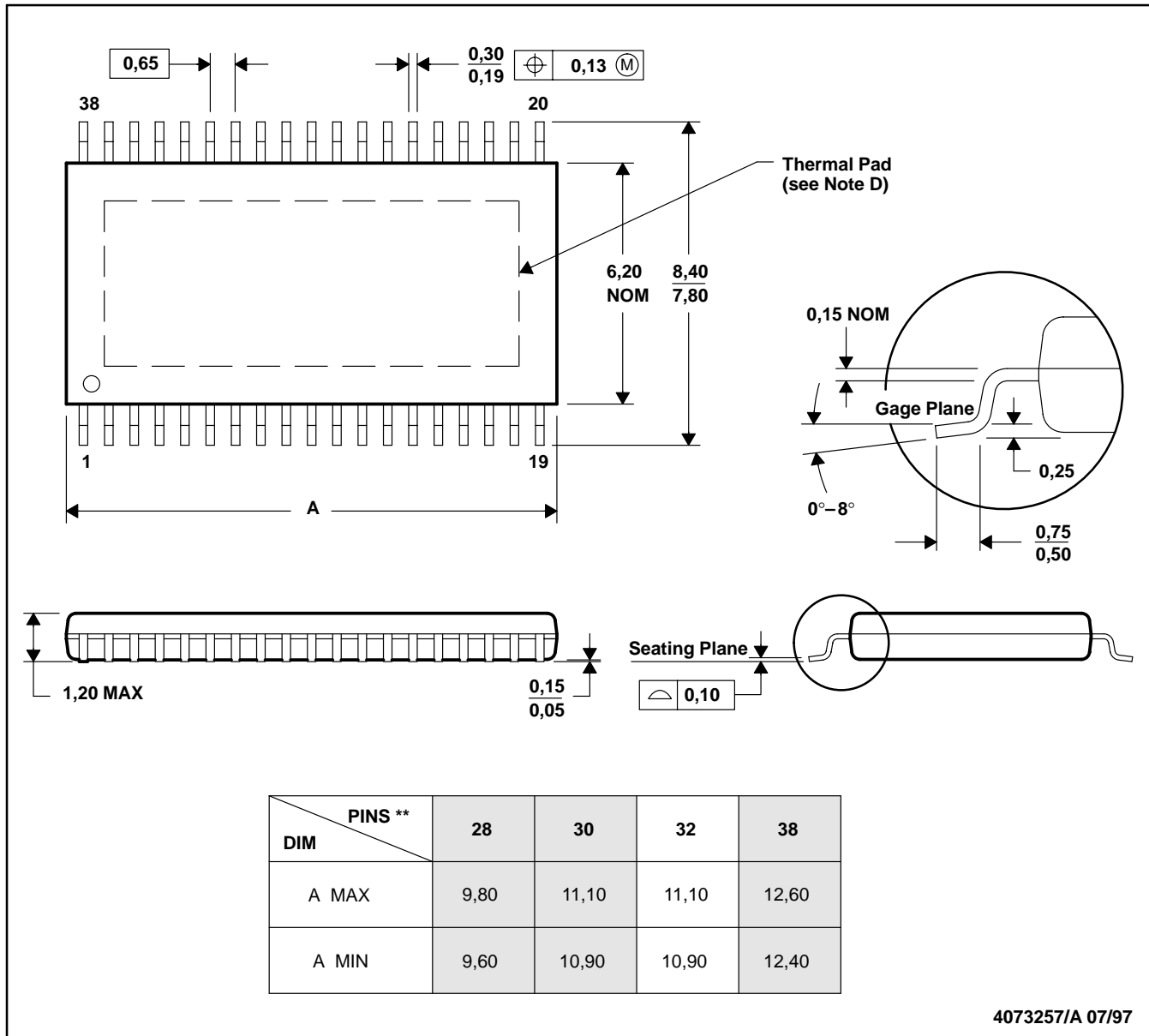

- NOTES: A. All linear dimensions are in millimeters.  
 B. This drawing is subject to change without notice.  
 C. Body dimensions do not include mold flash or protrusion.  
 D. The package thermal performance may be enhanced by bonding the thermal pad to an external thermal plane. This pad is electrically and thermally connected to the backside of the die and possibly selected leads. Thermal pad size is 3,86 mm X 3,91 mm for the 32-pin TAS5110 device.  
 E. Falls within JEDEC MO-153

PowerPAD is a trademark of Texas Instruments.

**MECHANICAL DATA**

**DAD (R-PDSO-G\*\*)**

**PowerPAD™ PLASTIC SMALL-OUTLINE (DIE DOWN)**

38 PINS SHOWN

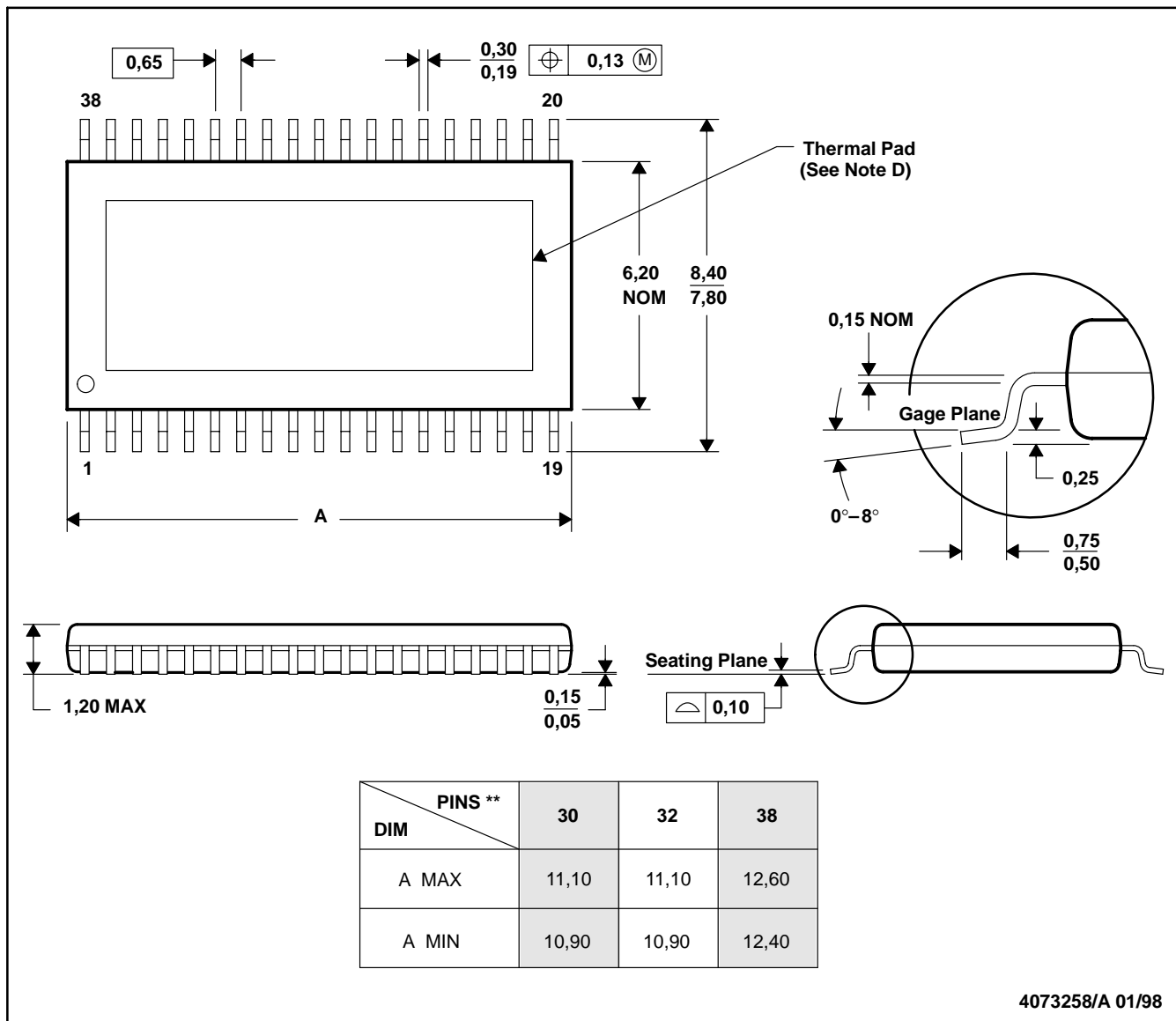

- NOTES:
- A. All linear dimensions are in millimeters.
  - B. This drawing is subject to change without notice.
  - C. Body dimensions include mold flash or protrusion.
  - D. The package thermal performance may be enhanced by attaching an external heatsink to the thermal pad. This pad is electrically and thermally connected to the backside of the die and possibly selected leads.
  - E. Falls within JEDEC MO-153

## **IMPORTANT NOTICE**

Texas Instruments Incorporated and its subsidiaries (TI) reserve the right to make corrections, modifications, enhancements, improvements, and other changes to its products and services at any time and to discontinue any product or service without notice. Customers should obtain the latest relevant information before placing orders and should verify that such information is current and complete. All products are sold subject to TI's terms and conditions of sale supplied at the time of order acknowledgment.

TI warrants performance of its hardware products to the specifications applicable at the time of sale in accordance with TI's standard warranty. Testing and other quality control techniques are used to the extent TI deems necessary to support this warranty. Except where mandated by government requirements, testing of all parameters of each product is not necessarily performed.

TI assumes no liability for applications assistance or customer product design. Customers are responsible for their products and applications using TI components. To minimize the risks associated with customer products and applications, customers should provide adequate design and operating safeguards.

TI does not warrant or represent that any license, either express or implied, is granted under any TI patent right, copyright, mask work right, or other TI intellectual property right relating to any combination, machine, or process in which TI products or services are used. Information published by TI regarding third-party products or services does not constitute a license from TI to use such products or services or a warranty or endorsement thereof. Use of such information may require a license from a third party under the patents or other intellectual property of the third party, or a license from TI under the patents or other intellectual property of TI.

Reproduction of information in TI data books or data sheets is permissible only if reproduction is without alteration and is accompanied by all associated warranties, conditions, limitations, and notices. Reproduction of this information with alteration is an unfair and deceptive business practice. TI is not responsible or liable for such altered documentation.

Resale of TI products or services with statements different from or beyond the parameters stated by TI for that product or service voids all express and any implied warranties for the associated TI product or service and is an unfair and deceptive business practice. TI is not responsible or liable for any such statements.

### **Mailing Address:**

Texas Instruments  
Post Office Box 655303  
Dallas, Texas 75265