

TCED1100(G) up to TCED4100

Vishay Telefunken



Optocoupler with Photodarlington Output

Description

The TCED1100/ TCED2100/ TCED4100 consists of a phototransistor optically coupled to a gallium arsenide infrared-emitting diode in a 4-lead up to 16-lead plastic dual inline package.

The elements are mounted on one leadframe using a **coplanar technique**, providing a fixed distance between input and output for highest safety requirements.

Applications

Circuits for safe protective separation against electrical shock according to safety class II (reinforced isolation):

- For appl. class I – IV at mains voltage ≤ 300 V
- For appl. class I – III at mains voltage ≤ 600 V according to VDE 0884, table 2, suitable for:

Switch-mode power supplies, line receiver, computer peripheral interface, microprocessor system interface.

VDE Standards

These couplers perform safety functions according to the following equipment standards:

- **VDE 0884**
Optocoupler for electrical safety requirements
- **IEC 950/EN 60950**
Office machines (applied for reinforced isolation for mains voltage ≤ 400 V_{RMS})
- **VDE 0804**
Telecommunication apparatus and data processing
- **IEC 65**
Safety for mains-operated electronic and related household apparatus

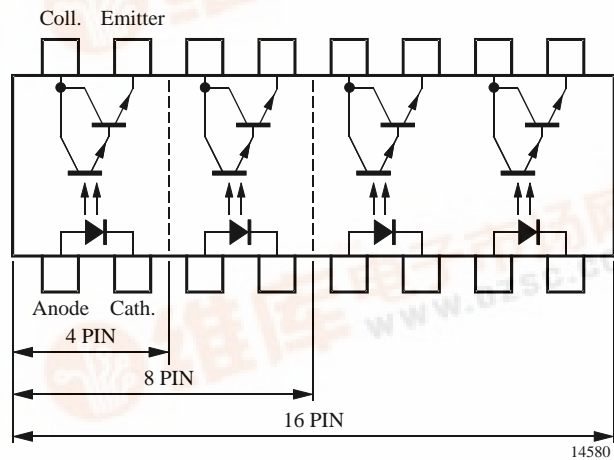
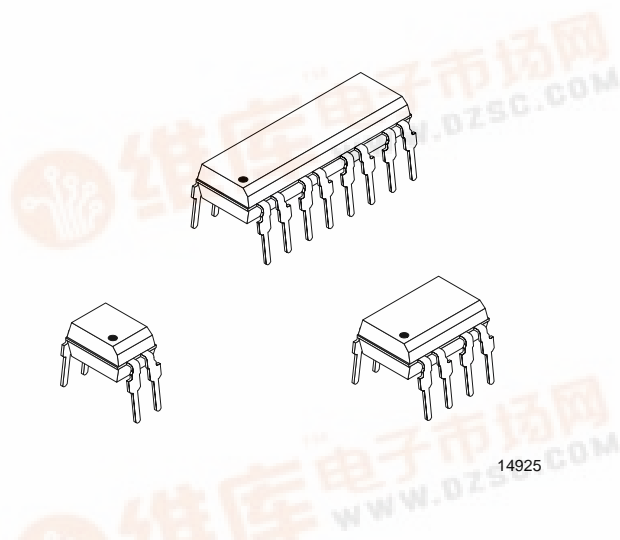

Order Instruction

Ordering Code	CTR Ranking	Remarks
TCED1100/ TCED1100G ¹⁾	600%	4 Pin = Single channel
TCED2100	600%	8 Pin = Dual channel
TCED4100	600%	16 Pin = Quad channel

¹⁾ G = Leadform 10.16 mm; G is not market on the body



TCED1100(G) up to TCED4100

Vishay Telefunken

Features

Approvals:

- **BSI:** BS EN 41003, BS EN 60095 (BS 415), BS EN 60950 (BS 7002), Certificate number 7081 and 7402
- **FIMKO (SETI):** EN 60950, Certificate number 11992
- **Underwriters Laboratory (UL) 1577** recognized, file number E-76222 – Double Protection
- **CSA (C-UL) 1577** recognized, file number E-76222 – Double Protection
- **VDE 0884**, Certificate number 115667

VDE 0884 related features:

- Rated impulse voltage (transient overvoltage) $V_{IOTM} = 8$ kV peak
- Isolation test voltage (partial discharge test voltage) $V_{pd} = 1.6$ kV
- Rated isolation voltage (RMS includes DC) $V_{IOWM} = 600 V_{RMS}$ (848 V peak)
- Rated recurring peak voltage (repetitive) $V_{IORM} = 600 V_{RMS}$

- Creepage current resistance according to VDE 0303/IEC 112
Comparative Tracking Index: **CTI** ≥ 175
- Thickness through insulation ≥ 0.75 mm
- Internal creepage distance > 4 mm

General features:

- Isolation materials according to UL94-VO
- Pollution degree 2 (DIN/VDE 0110/ resp. IEC 664)
- Climatic classification 55/100/21 (IEC 68 part 1)
- Special construction:
Therefore, extra low coupling capacity of typical 0.2 pF, high **Common Mode Rejection**
- Low temperature coefficient of CTR
- G = Leadform 10.16 mm; provides creepage distance > 8 mm, for TCED2100/ TCED4100 optional; suffix letter 'G' is not marked on the optocoupler
- Coupling System U

Absolute Maximum Ratings

Input (Emitter)

Parameter	Test Conditions	Symbol	Value	Unit
Reverse voltage		V_R	6	V
Forward current		I_F	60	mA
Forward surge current	$t_p \leq 10 \mu s$	I_{FSM}	1.5	A
Power dissipation	$T_{amb} \leq 25^\circ C$	P_V	100	mW
Junction temperature		T_j	125	$^\circ C$

Output (Detector)

Parameter	Test Conditions	Symbol	Value	Unit
Collector emitter voltage		V_{CEO}	35	V
Emitter collector voltage		V_{ECO}	7	V
Collector current		I_C	80	mA
Collector peak current	$t_p/T = 0.5, t_p \leq 10$ ms	I_{CM}	100	mA
Power dissipation	$T_{amb} \leq 25^\circ C$	P_V	150	mW
Junction temperature		T_j	125	$^\circ C$

Coupler

Parameter	Test Conditions	Symbol	Value	Unit
AC isolation test voltage (RMS)	$t = 1$ min	V_{IO}	5	kV
Total power dissipation	$T_{amb} \leq 25^\circ C$	P_{tot}	250	mW
Operating ambient temperature range		T_{amb}	-40 to +100	$^\circ C$
Storage temperature range		T_{stg}	-55 to +125	$^\circ C$
Soldering temperature	2 mm from case $t \leq 10$ s	T_{sd}	260	$^\circ C$

TCED1100(G) up to TCED4100

Vishay Telefunken



Electrical Characteristics ($T_{amb} = 25^{\circ}\text{C}$)

Input (Emitter)

Parameter	Test Conditions	Symbol	Min.	Typ.	Max.	Unit
Forward voltage	$I_F = 20 \text{ mA}$	V_F		1.15	1.4	V
Junction capacitance	$V_R = 0 \text{ V}, f = 1 \text{ MHz}$	C_j		50		pF

Output (Detector)

Parameter	Test Conditions	Symbol	Min.	Typ.	Max.	Unit
Collector emitter voltage	$I_C = 1 \text{ mA}$	V_{CEO}	32			V
Emitter collector voltage	$I_E = 100 \mu\text{A}$	V_{ECO}	7			V
Collector emitter cut-off current	$V_{CE} = 10 \text{ V}, I_F = 0, E = 0$	I_{CEO}		15	100	nA

Coupler

Parameter	Test Conditions	Symbol	Min.	Typ.	Max.	Unit
Collector emitter saturation voltage	$I_F = 20 \text{ mA}, I_C = 5 \text{ mA}$	V_{CEsat}			1	V
Cut-off frequency	$V_{CE} = 5 \text{ V}, I_F = 10 \text{ mA}, R_L = 100 \Omega$	f_c		10		kHz
Coupling capacitance	$f = 1 \text{ MHz}$	C_k		0.3		pF

Current Transfer Ratio (CTR)

Parameter	Test Conditions	Type	Symbol	Min.	Typ.	Max.	Unit
I_C/I_F	$V_{CE} = 2 \text{ V}, I_F = 1 \text{ mA}$	TCED1100(G)/ TCED2100/ TCED4100	CTR	6.0	8.0		



TCED1100(G) up to TCED4100

Vishay Telefunken

Maximum Safety Ratings (according to VDE 0884) see figure 1

This device is used for protective separation against electrical shock only within the maximum safety ratings. This must be ensured by using protective circuits in the applications.

Input (Emitter)

Parameters	Test Conditions	Symbol	Value	Unit
Forward current		I_{si}	130	mA

Output (Detector)

Parameters	Test Conditions	Symbol	Value	Unit
Power dissipation	$T_{amb} \leq 25^\circ\text{C}$	P_{si}	265	mW

Coupler

Parameters	Test Conditions	Symbol	Value	Unit
Rated impulse voltage		V_{IOTM}	8	kV
Safety temperature		T_{si}	150	$^\circ\text{C}$

Insulation Rated Parameters (according to VDE 0884)

Parameter	Test Conditions	Symbol	Min.	Typ.	Max.	Unit
Partial discharge test voltage – Routine test	100%, $t_{test} = 1\text{ s}$	V_{pd}	1.6			kV
Partial discharge test voltage – Lot test (sample test)	$t_{Tr} = 60\text{ s}$, $t_{test} = 10\text{ s}$, (see figure 2)	V_{IOTM}	8			kV
		V_{pd}	1.3			kV
Insulation resistance	$V_{IO} = 500\text{ V}$	R_{IO}	10^{12}			Ω
	$V_{IO} = 500\text{ V}$, $T_{amb} = 100^\circ\text{C}$	R_{IO}	10^{11}			Ω
	$V_{IO} = 500\text{ V}$, $T_{amb} = 150^\circ\text{C}$ (construction test only)	R_{IO}	10^9			Ω

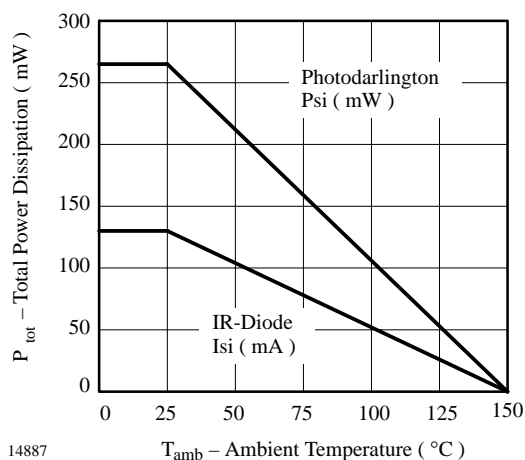

Figure 1. Derating diagram

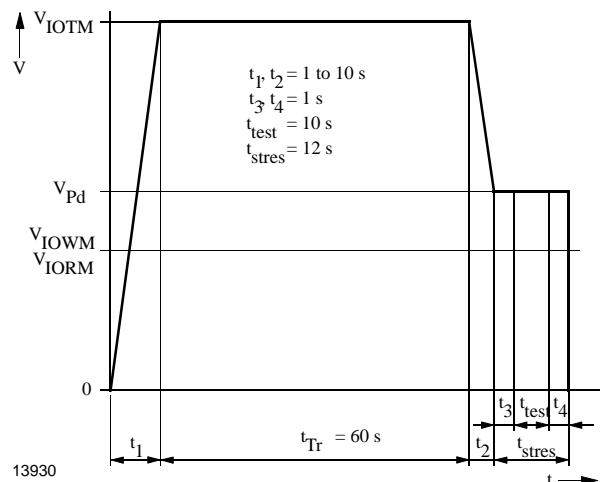

Figure 2. Test pulse diagram for sample test according to DIN VDE 0884

TCED1100(G) up to TCED4100

Vishay Telefunken



Switching Characteristics

Parameter	Test Conditions	Symbol	Typ.	Unit
Rise time	$V_{CC} = 2\text{ V}$, $I_C = 10\text{ mA}$, $R_L = 100\ \Omega$ (see figure 3)	t_r	300	μs
Fall time		t_f	250	μs

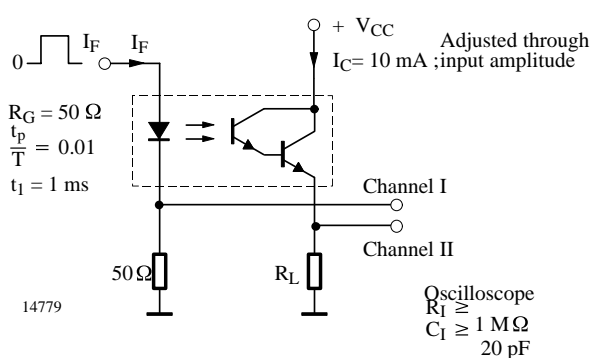

Figure 3. Test circuit

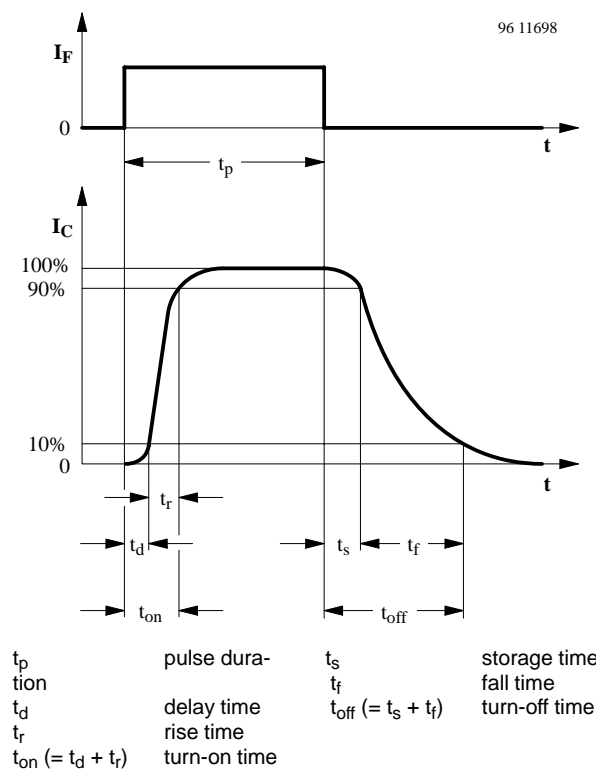
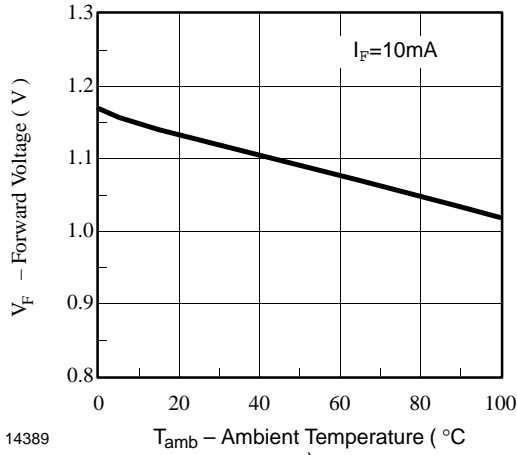

Figure 4. Switching times



Typical Characteristics ($T_{amb} = 25^{\circ}\text{C}$, unless otherwise specified)



14389

Figure 5. Forward Voltage vs. Ambient Temperature

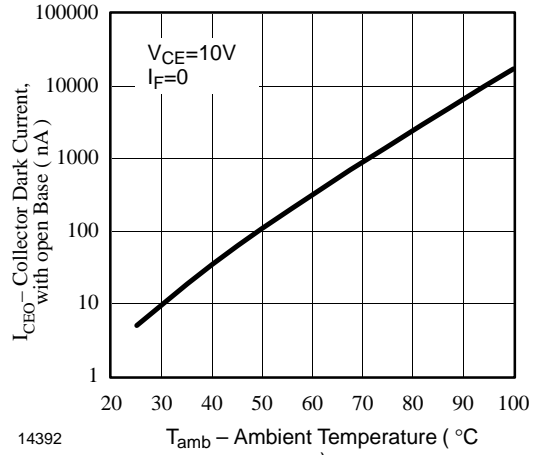

14392

Figure 8. Collector Dark Current vs. Ambient Temperature

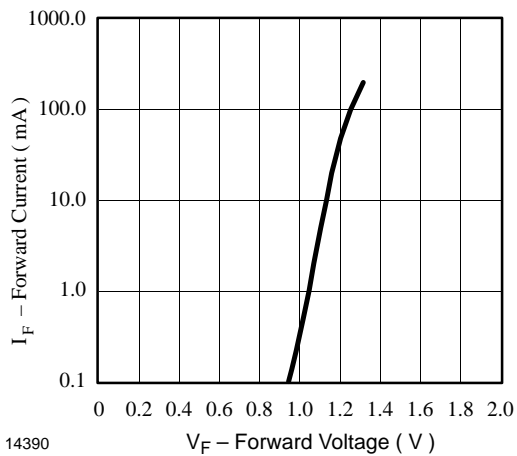

14390

Figure 6. Forward Current vs. Forward Voltage

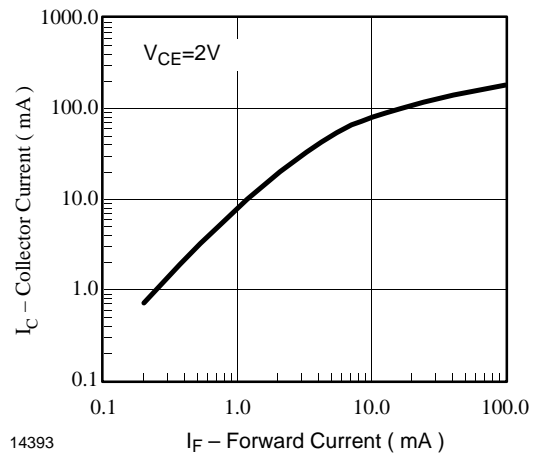

14393

Figure 9. Collector Current vs. Forward Current

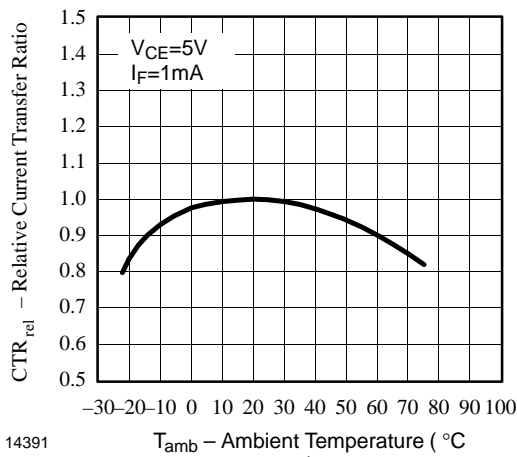

14391

Figure 7. Relative Current Transfer Ratio vs. Ambient Temperature

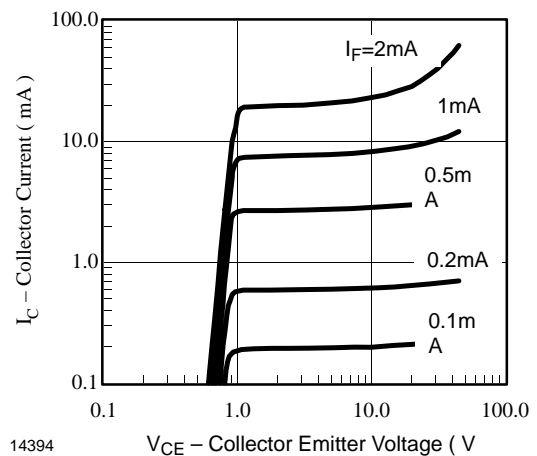

14394

Figure 10. Collector Current vs. Collector Emitter Voltage

TCED1100(G) up to TCED4100

Vishay Telefunken

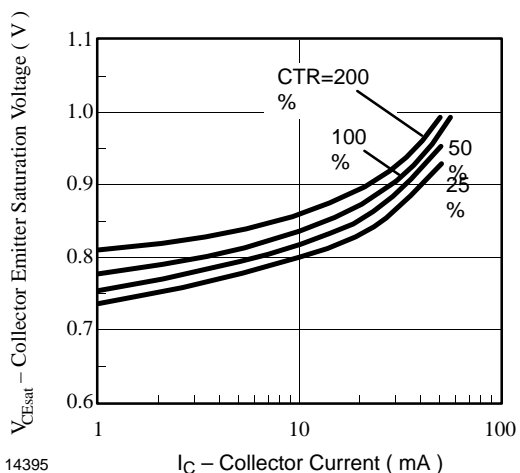

Figure 11. Collector-Emitter Saturation Voltage vs. Collector Current

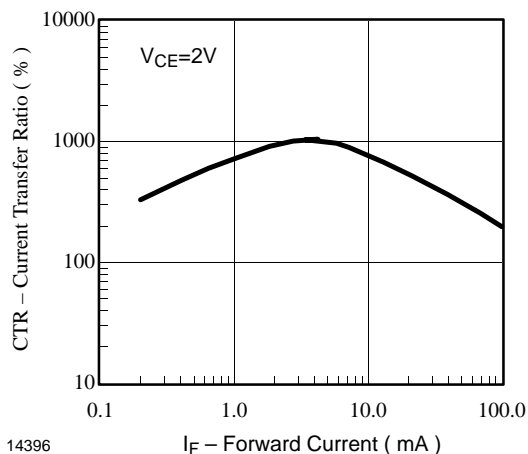

Figure 13. Current Transfer Ratio vs. Forward Current

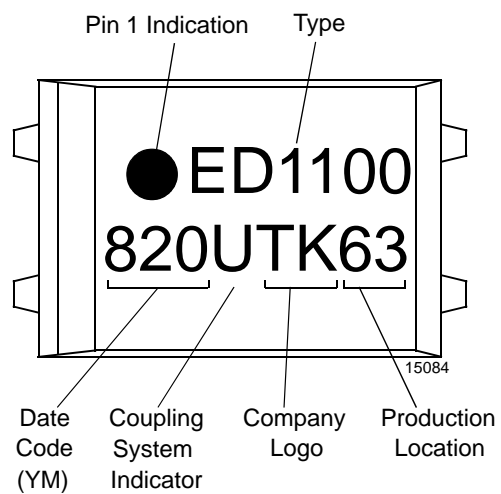

Figure 12. Marking example



TCED1100(G) up to TCED4100

Vishay Telefunken

Dimensions of TCED1100 in mm

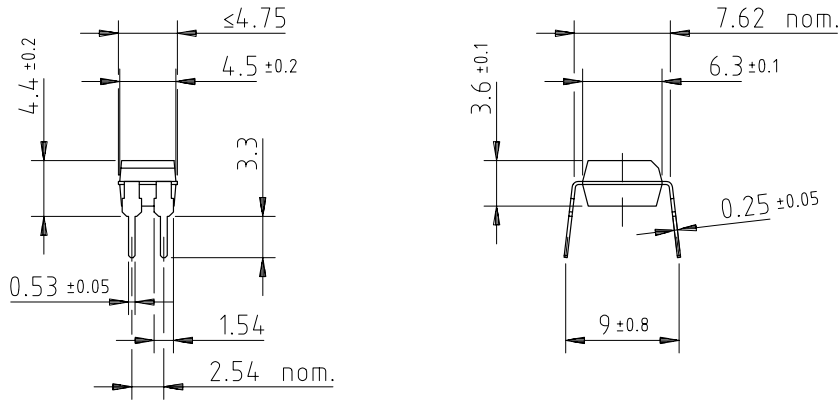

E.g.:
special Features: endstackable
to 2.54mm (.100") spacing

weight: ca. 0.25 g
creepage distance: $\geq 6 \text{ mm}$
air path: $\geq 6 \text{ mm}$

after mounting on PC board

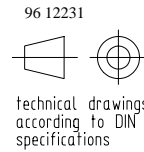
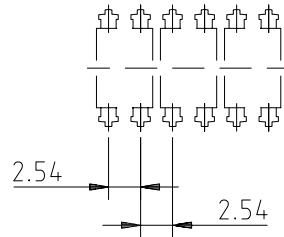
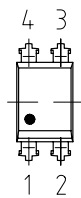

Dimensions of TCED1100G in mm

Leadform 10.16 mm (G_type)

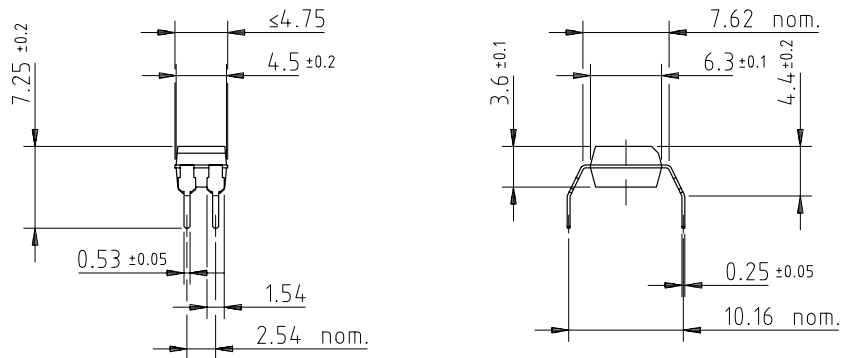

E.g.:
special Features: endstackable
to 2.54mm (.100") spacing

weight: ca. 0.25 g
creepage distance: $\geq 8 \text{ mm}$
air path: $\geq 8 \text{ mm}$

after mounting on PC board

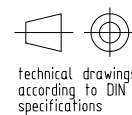
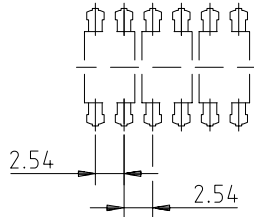
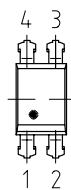

9612234

TCED1100(G) up to TCED4100

Vishay Telefunken



Dimensions of TCED2100 in mm

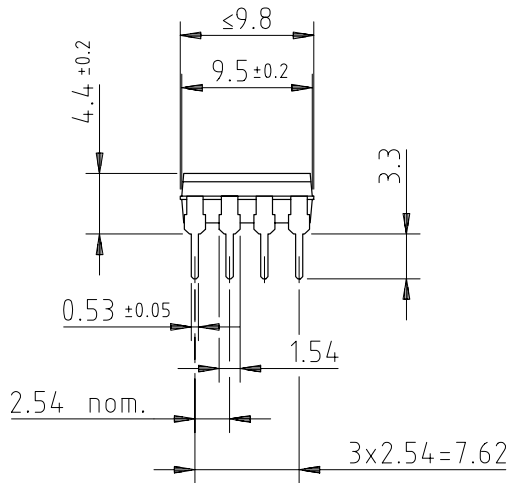

weight: ca. 0.5 g
 creepage distance: $\geq 6 \text{ mm}$
 air path: $\geq 6 \text{ mm}$

after mounting on PC board

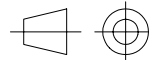

technical drawings according to DIN specifications

96 12228

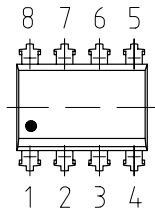

Dimensions of TCED4100 in mm

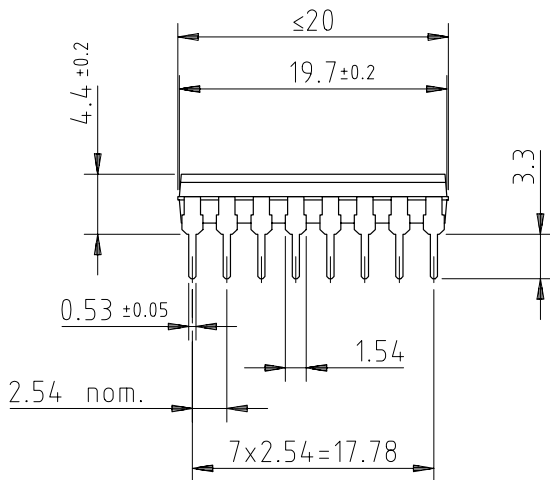

weight: ca. 1.1 g
 creepage distance: $\geq 6 \text{ mm}$
 air path: $\geq 6 \text{ mm}$

after mounting on PC board

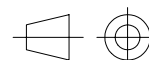

technical drawings according to DIN specifications

96 12227

