

TMC3033

Triple Video D/A Converter

10 bit, 80 Msps

Features

- 10-bit resolution
- 80, 50, and 30 megapixels per second
- Sync and blank controls
- Sync on green D/A output
- 1.0V p-p video into 37.5Ω or 75Ω load
- Enhancement of ADV7122
 - Internal bandgap voltage reference
 - Double-buffered data for low distortion
- TTL-compatible inputs
- Low glitch energy
- Single +3.3 Volt ±5% power supply

Applications

- Video signal conversion
 - RGB
 - YCbCr
 - Composite, Y, C
- Multimedia systems
- Image processing
- True-color graphics systems (1 billion colors)
- Broadcast television equipment
- High-Definition Television (HDTV) equipment
- Direct digital synthesis

Description

The TMC3033 is a high-speed triple 10-bit D/A converter especially suited for video and graphics applications. It offers 10-bit resolution, TTL-compatible inputs, low power consumption, and requires only a single +3.3 Volt ±5% power supply. It has single-ended current outputs, SYNC and BLANK control inputs, and a separate current source for adding sync pulses to the Green D/A converter output. It is ideal for generating analog RGB from digital RGB and driving computer display and video monitors. Three speed grades are available: 30, 50, and 80 Msps.

The TMC3033 triple D/A converter is available in a 44-lead plastic J-leaded PLCC and 48-lead plastic LQFP package. It is fabricated on a sub-micron CMOS process with performance guaranteed from 0°C to 70°C.

Block Diagram

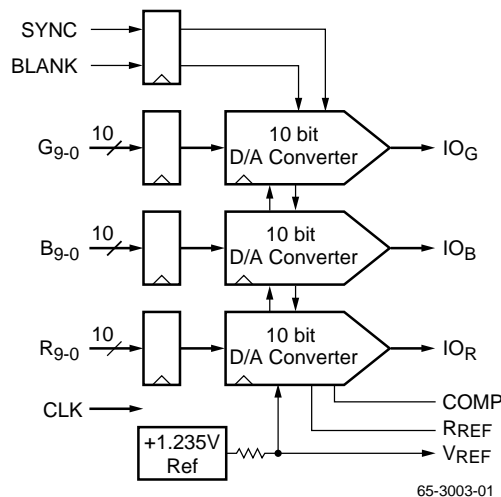

Functional Description

The TMC3033 is a low-cost triple 10-bit CMOS D/A converter designed to directly drive computer CRT displays and video transmission lines at pixel rates of up to 80 Msp. It comprises three identical 10-bit D/A converters with registered data inputs, common clock, and internal voltage reference. An independent current source allows sync to be added to the green D/A converter output.

Digital Inputs

All digital inputs are TTL-compatible. Data are registered on the rising edge of the CLK signal. The analog output changes t_{DO} after the rising edge of CLK. There is one stage of pipeline delay on the chip. The guaranteed clock rates of the TMC3033 are 80, 50, and 30 MHz.

SYNC and BLANK

$\overline{\text{SYNC}}$ and $\overline{\text{BLANK}}$ inputs control the output level (Figure 1 and Table 1) of the D/A converters during CRT retrace intervals. $\overline{\text{BLANK}}$ forces the D/A outputs to the blanking level while $\overline{\text{SYNC}}$ turns off a separate current source which is connected to the green D/A converter. This connection adds a 40 IRE sync pulse to the D/A output and brings that D/A output to 0.0 Volts during the sync tip. $\overline{\text{SYNC}}$ and $\overline{\text{BLANK}}$ are registered on the rising edge of CLK.

$\overline{\text{BLANK}}$ gates the D/A inputs and sets the pedestal voltage. If $\overline{\text{BLANK}} = \text{HIGH}$, the D/A inputs are added to a pedestal which offsets the current output. If $\overline{\text{BLANK}} = \text{LOW}$, data inputs and the pedestal are disabled.

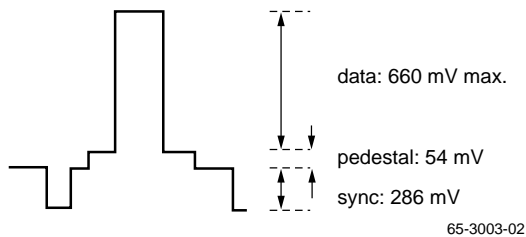

Figure 1. Nominal Output Levels

D/A Outputs

Each D/A output is a current source. To obtain a voltage output a resistor must be connected to ground. Output voltage of the D/A converters depends upon this resistor, the reference voltage, and the value of the gain-setting resistor connected between RREF and GND.

Normally, a source termination resistor of 75 Ohms is connected between the D/A current output pin and GND near the D/A converter. A 75 Ohm coaxial cable may then be connected with another 75 Ohm termination resistor at the far end of the cable. This “double termination” presents the D/A converter with a net resistive load of 37.5 Ohms.

The TMC3033 may also be operated with a single 75 Ohm terminating resistor. To lower the output voltage swing to the desired range, the value of the resistor on RREF should be increased.

Voltage Reference

The TMC3033 has an internal bandgap voltage reference of +1.235 Volts. An external voltage reference may be connected to the VREF pin, overriding the internal voltage reference. All three D/A converters are driven from the same reference.

A 0.1 μF capacitor must be connected between the COMP pin and VDD to stabilize internal bias circuitry and ensure low-noise operation.

Power and Ground

The TMC3033 D/A converter requires a single +3.3 Volt power supply. The analog (VDD) power supply voltage should be decoupled to GND to reduce power supply induced noise. 0.1 μF decoupling capacitors should be placed as close as possible to the power pins.

The high slew-rate of digital data makes capacitive coupling to the outputs of any D/A converter a potential problem. Since the digital signals contain high-frequency components of the CLK signal, as well as the video output signal, the resulting data feedthrough often looks like harmonic distortion or reduced signal-to-noise performance. All ground pins should be connected to a common solid ground plane for best performance.

Table 1. Output Voltage versus Input Code, SYNC, and BLANK

VREF = 1.235 V, RREF = 572 Ω, RL = 37.5 Ω

| RGB9-0 (MSB...LSB) | Red and Blue D/As | | | Green D/A | | |
|-----------------------|-------------------|-------|--------|-----------|-------|--------|
| | SYNC | BLANK | VOUT | SYNC | BLANK | VOUT |
| 11 1111 1111 | X | 1 | 0.7140 | 1 | 1 | 1.0000 |
| 11 1111 1110 | X | 1 | 0.7134 | 1 | 1 | 0.9994 |
| 11 1111 1101 | X | 1 | 0.7127 | 1 | 1 | 0.9987 |
| • | • | • | • | • | • | • |
| • | • | • | • | • | • | • |
| 10 0000 0000 | X | 1 | 0.3843 | 1 | 1 | 0.6703 |
| 01 1111 1111 | X | 1 | 0.3837 | 1 | 1 | 0.6697 |
| • | • | • | • | • | • | • |
| • | • | • | • | • | • | • |
| 00 0000 0010 | X | 1 | 0.0553 | 1 | 1 | 0.3413 |
| 00 0000 0001 | X | 1 | 0.0546 | 1 | 1 | 0.3406 |
| 00 0000 0000 | X | 1 | 0.0540 | 1 | 1 | 0.3400 |
| xx xxxx xxxx | X | 0 | 0.0000 | 1 | 0 | 0.2860 |
| xx xxxx xxxx | X | 0 | 0.0000 | 0 | 0 | 0.0000 |

Pin Assignments

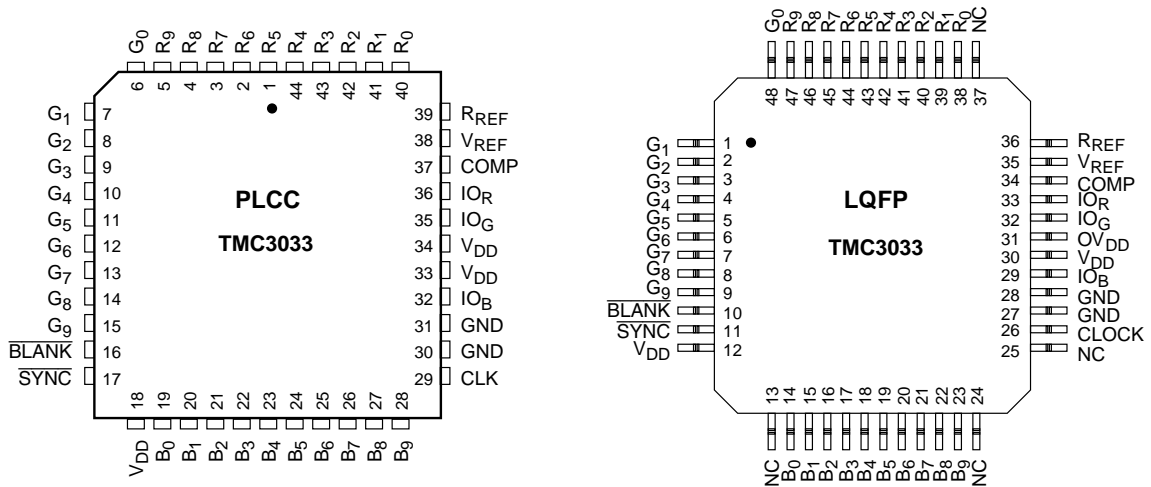

Pin Descriptions

| Pin Name | Pin Number | | Value | Description |
|----------------------------|--|--|------------|--|
| | PLCC | LQFP | | |
| Clock and Pixel I/O | | | | |
| CLK | 29 | 26 | TTL | Clock. The clock input is TTL-compatible and all pixel data is registered on the rising edge of CLK. It is recommended that CLK be driven by a dedicated TTL buffer to avoid reflection induced jitter, overshoot, and undershoot. |
| R9-0 | 5, 4, 3, 2, 1, 44, 43, 42, 41, 40 | 47, 46, 45, 44, 43, 42, 41, 40, 39, 38, 37 | TTL | Red pixel data inputs. The Red digital input is TTL-compatible and registered on the rising edge of CLK. |
| G9-0 | 15, 14, 13, 12, 11, 10, 9, 8, 7, 6 | 48, 9, 8, 7, 6, 5, 4, 3, 2, 1 | TTL | Green pixel data inputs. The Green digital input is TTL-compatible and registered on the rising edge of CLK. |
| B9-0 | 28, 27, 26, 25, 24, 23, 22, 21, 20, 19 | 23, 22, 21, 20, 19, 18, 17, 16, 15, 14 | TTL | Blue pixel data inputs. The Blue digital input is TTL-compatible and registered on the rising edge of CLK. |
| Controls | | | | |
| SYNC | 17 | 11 | TTL | <p>Sync pulse Input. Bringing SYNC LOW, turns off a 40 IRE (7.62 mA) current source which forms a sync pulse on the Green D/A converter output. SYNC is registered on the rising edge of CLK along with pixel data and has the same pipeline latency as BLANK and pixel data. SYNC does not override any other data and should be used only during the blanking interval.</p> <p>Since this is a single-supply D/A and all signals are positive-going, sync is added to the bottom of the Green D/A range. So turning SYNC OFF means turning the current source ON. When a sync pulse is desired, the current source is turned OFF. If the system does not require sync pulses from the Green D/A converter, SYNC should be connected to GND.</p> |
| BLANK | 16 | 10 | TTL | Blanking Input. When BLANK is LOW, pixel inputs are ignored and the D/A converter outputs are driven to the blanking level. BLANK is registered on the rising edge of CLK and has the same pipeline latency as SYNC. |
| Video Outputs | | | | |
| IOR | 36 | 33 | 0.714 Vp-p | Red D/A output. The current source outputs of the D/A converters are capable of driving RS-343A/SMPTE-170M compatible levels into doubly-terminated 75 Ohm lines. |
| IOG | 35 | 32 | 1 V p-p | Green D/A output. The current source outputs of the D/A converters are capable of driving RS-343A/SMPTE-170M compatible levels into doubly-terminated 75 Ohm lines. Sync pulses may be added to the Green D/A output. |
| IOB | 32 | 29 | 0.714 Vp-p | Blue D/A output. The current source outputs of the D/A converters are capable of driving RS-343A/SMPTE-170M compatible levels into doubly-terminated 75 Ohm lines. |

Pin Descriptions (continued)

| Pin Name | Pin Number | | Value | Description |
|--------------------------|------------|------------|----------|---|
| | PLCC | LQFP | | |
| Voltage Reference | | | | |
| VREF | 38 | 35 | +1.235 V | Voltage Reference output/input. An internal voltage source of +1.235 Volts is output on this pin. An external +1.235 Volt reference may be applied here which overrides the internal reference. Decoupling VREF to GND with a 0.1µF ceramic capacitor is required. |
| RREF | 39 | 36 | 572 Ω | Current-setting resistor. The full-scale output current of each D/A converter is determined by the value of the resistor connected between RREF and GND. The nominal value for RREF is found from: $R_{REF} = 9.1 (V_{REF}/I_{FS}),$ but is optimized to be 572 Ω. I _{FS} is the full-scale (white) output current (in amps) from an output without sync. Sync current is 0.4 * I _{FS} . D/A full-scale (white) current may also be calculated from: $I_{FS} = V_{FS}/R_L$ Where V _{FS} is the white voltage level and R _L is the total resistive load (in ohms) on each D/A converter. V _{FS} is the blank to full-scale voltage. |
| COMP | 37 | 34 | 0.1 µF | Compensation capacitor. A 0.1 µF ceramic capacitor must be connected between COMP and V _{DD} to stabilize internal bias circuitry. |
| Power and Ground | | | | |
| VDD | 18, 33, 34 | 12, 30, 31 | +3.3 V | Power supply |
| GND | 30, 31 | 27, 28 | 0.0 V | Ground |

Equivalent Circuits

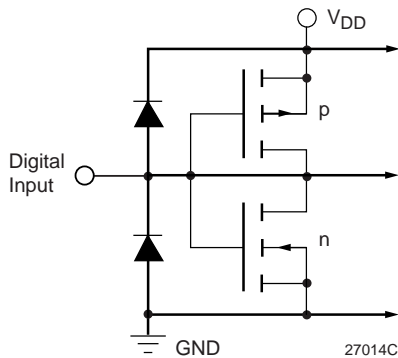

Figure 2. Equivalent Digital Input Circuit

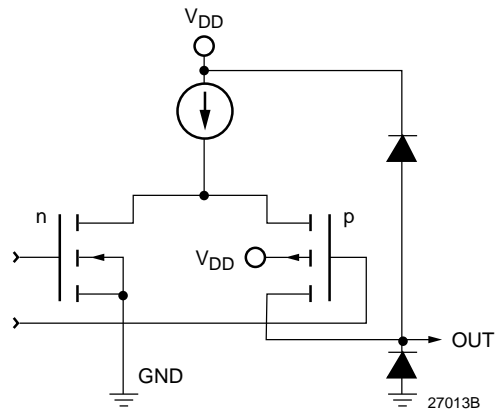

Figure 3. Equivalent Analog Output Circuit

Equivalent Circuits (continued)

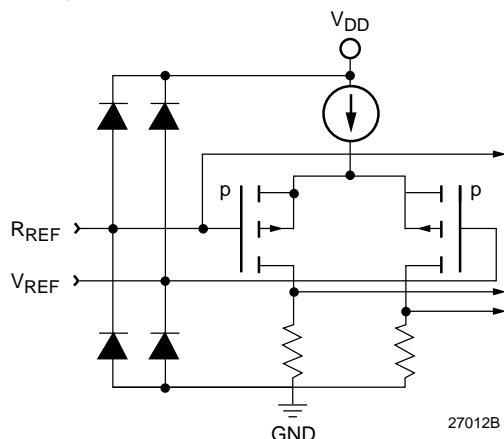

Figure 4. Equivalent Analog Input Circuit

Absolute Maximum Ratings (beyond which the device may be damaged)¹

| Parameter | Min | Typ | Max | Unit |
|--|-------|-----|-----------|--------|
| Power Supply Voltage | | | | |
| VDD (Measured to GND) | -0.5 | | 7.0 | V |
| Inputs | | | | |
| Applied Voltage (measured to GND) ² | -0.5 | | VDD + 0.5 | V |
| Forced Current ^{3,4} | -10.0 | | 10.0 | mA |
| Outputs | | | | |
| Applied Voltage (measured to GND) ² | -0.5 | | VDD + 0.5 | V |
| Forced Current ^{3,4} | -60.0 | | 60.0 | mA |
| Short Circuit Duration (single output in HIGH state to ground) | | | infinite | second |
| Temperature | | | | |
| Operating, Ambient | -20 | | 110 | °C |
| Junction | | | 150 | °C |
| Lead Soldering (10 seconds) | | | 300 | °C |
| Vapor Phase Soldering (1 minute) | | | 220 | °C |
| Storage | -65 | | 150 | °C |

Notes:

1. Functional operation under any of these conditions is NOT implied. Performance and reliability are guaranteed only if Operating Conditions are not exceeded.
2. Applied voltage must be current limited to specified range.
3. Forcing voltage must be limited to specified range.
4. Current is specified as conventional current flowing into the device.

Operating Conditions

| Parameter | | Min | Nom | Max | Units |
|-----------|--------------------------------|------------|-------|-------|--------------|
| VDD | Power Supply Voltage | 3.135 | 3.3 | 3.465 | V |
| fS | Conversion Rate | TMC3033-30 | | 30 | MSPS |
| | | TMC3033-50 | | 50 | MSPS |
| | | TMC3033-80 | | 80 | MSPS |
| tPWH | CLK Pulsewidth, HIGH | 5.2 | | | ns |
| tPWL | CLK Pulsewidth, LOW | 5.2 | | | ns |
| tS | Input Data Setup Time | 3.6 | | | ns |
| tH | Input Data Hold Time | 2 | | | ns |
| VREF | Reference Voltage, External | 1.0 | 1.235 | 1.5 | V |
| CC | Compensation Capacitor | | 0.1 | | μ F |
| RL | Output Load | | 37.5 | | Ω |
| VIH | Input Voltage, Logic HIGH | 2.0 | | VDD | V |
| VIL | Input Voltage, Logic LOW | GND | | 0.8 | V |
| TA | Ambient Temperature, Still Air | 0 | | 70 | $^{\circ}$ C |

Electrical Characteristics

| Parameter | Conditions ³ | Min | Typ ¹ | Max | Units | |
|-----------|--------------------------------------|-----------------------|------------------|-----------|------------|----|
| IDD | Power Supply Current ² | VDD = Max | | | | mA |
| | | TMC3033-30 | | | 90 | |
| | | TMC3033-50 | | | 95 | |
| | | TMC3033-80 | | | 132 | |
| PD | Total Power Dissipation ² | VDD = Max | | | | mW |
| | | TMC3033-30 | | | 300 | |
| | | TMC3033-50 | | | 315 | |
| | | TMC3033-80 | | | 435 | |
| RO | Output Resistance | | 100 | | k Ω | |
| CO | Output Capacitance | IOUT = 0mA | | 30 | pF | |
| IiH | Input Current, HIGH | VDD = Max, VIN = 2.4V | | -1 | μ A | |
| IiL | Input Current, LOW | VDD = Max, VIN = 0.4V | | 1 | μ A | |
| IREF | VREF Input Bias Current | | 0 | \pm 100 | μ A | |
| VREF | Reference Voltage Output | | 1.235 | | V | |
| VOC | Output Compliance | Referred to VDD | -0.4 | 0 | +1.5 | V |
| CDI | Digital Input Capacitance | | 4 | 10 | pF | |

Notes:

- Values shown in Typ column are typical for VDD = +3.3V and TA = 25 $^{\circ}$ C.
- Minimum/Maximum values with VDD = Max and TA = Min.
- VREF = 1.235V, RLOAD = 37.5 Ω , RREF = 572 Ω

Switching Characteristics

| Parameter | Conditions ² | Min | Typ ¹ | Max | Units |
|-------------------|-------------------------|--------------------------|------------------|-----|-------|
| t _D | Clock to Output Delay | V _{DD} = Min | 10 | 15 | ns |
| t _{SKEW} | Output Skew | | 1 | 2 | ns |
| t _R | Output Risetime | 10% to 90% of Full Scale | 3 | 4 | ns |
| t _F | Output Falltime | 90% to 10% of Full Scale | 3 | 4 | ns |
| t _{SET} | Output Settling Time | to 3%/FS | 15 | | ns |

Notes:

1. Values shown in Typ column are typical for V_{DD} = +3.3V and T_A = 25°C.
2. V_{REF} = 1.235V, R_{LOAD} = 37.5Ω, R_{REF} = 572Ω.

System Performance Characteristics

| Parameter | Conditions ² | Min | Typ ¹ | Max | Units |
|-----------|------------------------------|--|------------------|-------|-------|
| ELI | Integral Linearity Error | V _{DD} , V _{REF} = Nom | ±0.1 | ±0.25 | %/FS |
| ELD | Differential Linearity Error | V _{DD} , V _{REF} = Nom | ±0.1 | ±0.25 | %/FS |
| EDM | DAC to DAC Matching | V _{DD} , V _{REF} = Nom | 7 | 10 | % |
| VOF | Output Offset Current | V _{DD} = Max, R, G, B = 000h | | 20 | mA |
| PSR | Power Supply Rejection | | | 0.05 | %/% |

Notes:

1. Values shown in Typ column are typical for V_{DD} = +3.3V and T_A = 25°C.
2. V_{REF} = 1.235V, R_{LOAD} = 37.5Ω, R_{REF} = 572Ω.

Timing Diagram

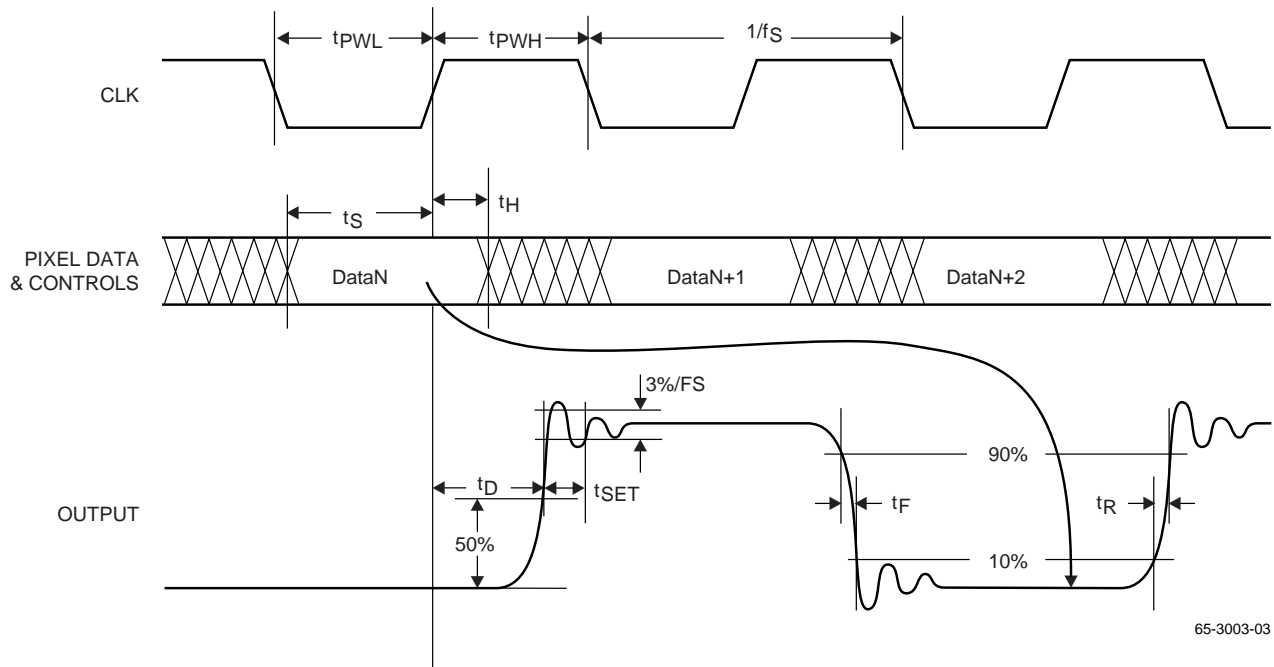

Applications Discussion

Figure 4 illustrates a typical TMC3033 interface circuit. In this example, an optional 1.2 Volt bandgap reference is connected to the VREF output, overriding the internal voltage reference source.

Grounding

It is important that the TMC3033 power supply is well-regulated and free of high-frequency noise. Careful power supply decoupling will ensure the highest quality video signals at the output of the circuit. The TMC3033 has separate analog and digital circuits. To keep digital system noise from the D/A converter, it is recommended that power supply voltages (VDD) come from the system analog power source and all ground connections (GND) be made to the analog ground plane. Power supply pins should be individually decoupled at the pin.

Printed Circuit Board Layout

Designing with high-performance mixed-signal circuits demands printed circuits with ground planes. Overall system performance is strongly influenced by the board layout. Capacitive coupling from digital to analog circuits may result in poor D/A conversion. Consider the following suggestions when doing the layout:

1. Keep the critical analog traces (VREF, IREF, COMP, IOR, IOG, IOB) as short as possible and as far as possible from all digital signals. The TMC3033 should be located near the board edge, close to the analog output connectors.
2. The power plane for the TMC3033 should be separate from that which supplies the digital circuitry. A single power plane should be used for all of the VDD pins. If

the power supply for the TMC3033 is the same as that of the system's digital circuitry, power to the TMC3033 should be decoupled with 0.1μF and 0.01μF capacitors and isolated with a ferrite bead.

3. The ground plane should be solid, not cross-hatched. Connections to the ground plane should have very short leads.
4. If the digital power supply has a dedicated power plane layer, it should not be placed under the TMC3033, the voltage reference, or the analog outputs. Capacitive coupling of digital power supply noise from this layer to the TMC3033 and its related analog circuitry can have an adverse effect on performance.
5. CLK should be handled carefully. Jitter and noise on this clock will degrade performance. Terminate the clock line carefully to eliminate overshoot and ringing.

Related Products

- TMC3503 Triple 8-bit 80 Msps D/A Converters
- TMC1175A 40 Msps CMOS 8-bit A/D Converter
- TMC1275 40 Msps CMOS 8-bit A/D Converter
- TMC22091, TMC22191 Digital Video Encoders
- TMC2242C/TMC2243/TMC2246A Video Filters
- TMC2249A Digital Mixer
- TMC2250A Matrix Multiplier
- TMC2272A Colorspace Converter
- TMC2302 Image Manipulation Sequencer
- TMC2340A Digital Synthesizer
- TMC2081 Digital Video Mixer

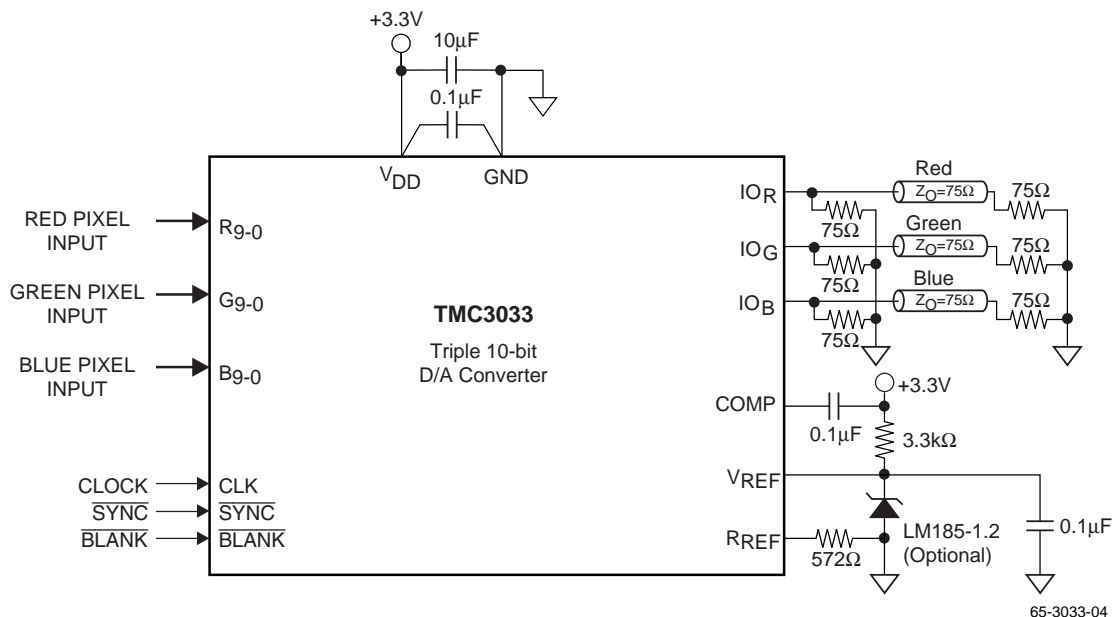

Figure 4. Typical Interface Circuit

Mechanical Dimensions – 44-Lead PLCC Package

| Symbol | Inches | | Millimeters | | Notes |
|--------|----------|------|-------------|-------|-------|
| | Min. | Max. | Min. | Max. | |
| A | .165 | .180 | 4.19 | 4.57 | |
| A1 | .090 | .120 | 2.29 | 3.05 | |
| A2 | .020 | — | .51 | — | |
| B | .013 | .021 | .33 | .53 | |
| B1 | .026 | .032 | .66 | .81 | |
| D/E | .685 | .695 | 17.40 | 17.65 | |
| D1/E1 | .650 | .656 | 16.51 | 16.66 | 3 |
| D3/E3 | .500 BSC | | 12.7 BSC | | |
| e | .050 BSC | | 1.27 BSC | | |
| J | .042 | .056 | 1.07 | 1.42 | 2 |
| ND/NE | 11 | | 11 | | |
| N | 44 | | 44 | | |
| ccc | — | .004 | — | 0.10 | |

Notes:

1. All dimensions and tolerances conform to ANSI Y14.5M-1982
2. Corner and edge chamfer (J) = 45°
3. Dimension D1 and E1 do not include mold protrusion. Allowable protrusion is .101" (.25mm)

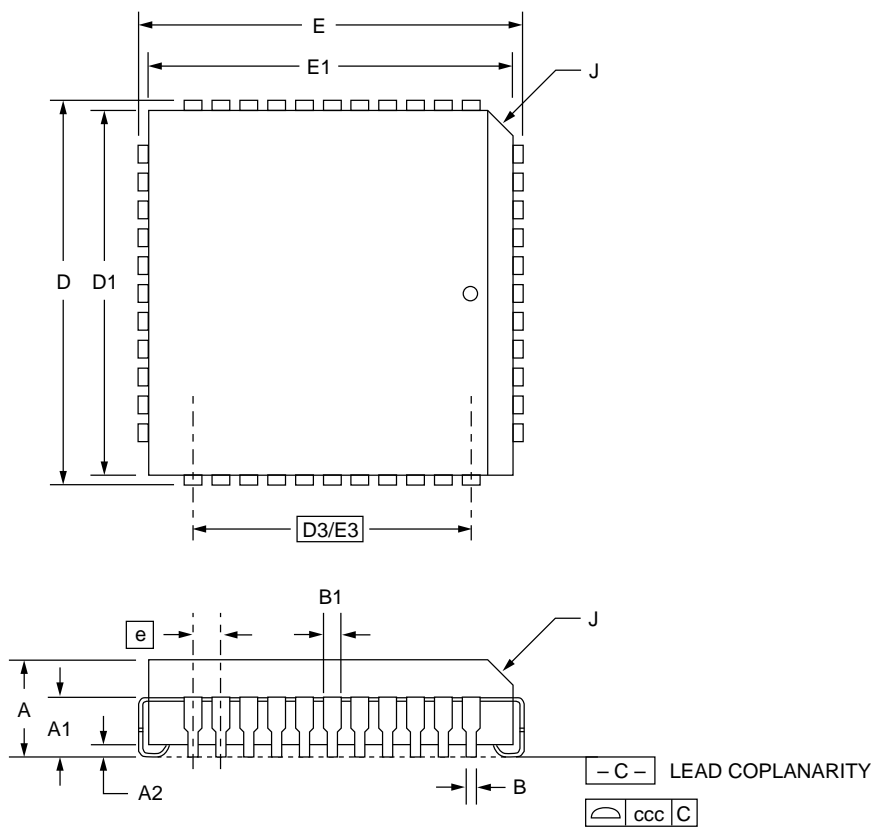

Mechanical Dimensions – 48-Lead LQFP Package

| Symbol | Inches | | Millimeters | | Notes |
|----------|----------|------|-------------|------|-------|
| | Min. | Max. | Min. | Max. | |
| A | .055 | .063 | 1.40 | 1.60 | |
| A1 | .001 | .005 | .05 | .15 | |
| A2 | .053 | .057 | 1.35 | 1.45 | |
| B | .006 | .010 | .17 | .27 | 7 |
| D/E | .346 | .362 | 8.8 | 9.2 | 8 |
| D1/E1 | .268 | .284 | 6.8 | 7.2 | 2 |
| e | .019 BSC | | .50 BSC | | |
| L | .017 | .029 | .45 | .75 | 6 |
| N | 48 | | 48 | | 4 |
| ND | 12 | | 12 | | 5 |
| α | 0° | 7° | 0° | 7° | |
| ccc | .004 | | 0.08 | | |

Notes:

1. All dimensions and tolerances conform to ANSI Y14.5M-1982.
2. Dimensions "D1" and "E1" do not include mold protrusion. Allowable protrusion is 0.25mm per side. D1 and E1 are maximum plastic body size dimensions including mold mismatch.
3. Pin 1 identifier is optional.
4. Dimension ND: Number of terminals.
5. Dimension ND: Number of terminals per package edge.
6. "L" is the length of terminal for soldering to a substrate.
7. Dimension "B" does not include dambar protrusion. Allowable dambar protrusion shall not cause the lead width to exceed the maximum B dimension by more than 0.08mm. Dambar can not be located on the lower radius or the foot. Minimum space between protrusion and an adjacent lead is 0.07mm for 0.4mm and 0.5mm pitch packages.
8. To be determined at seating place —C—

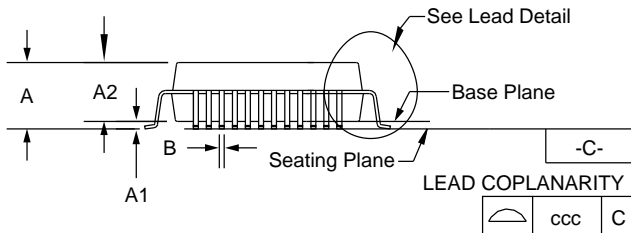
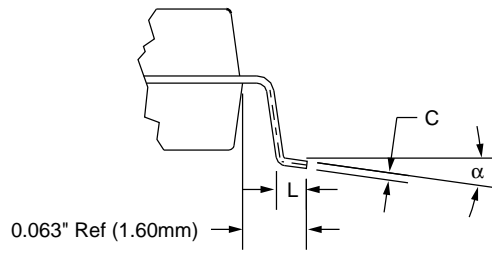
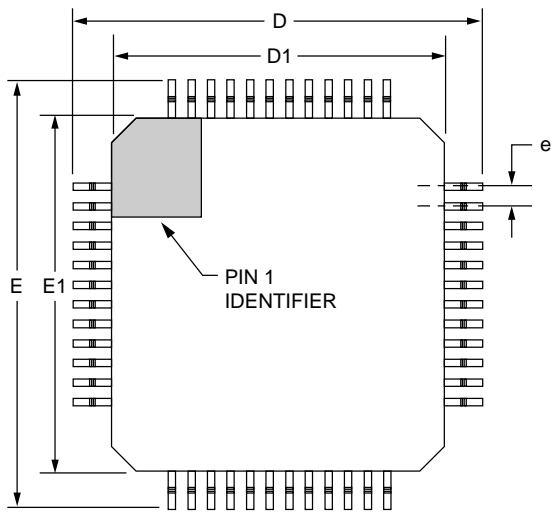

Ordering Information

| Product Number | Conversion Rate (Msps) | Temperature Range | Screening | Package | Package Marking |
|----------------|------------------------|------------------------------|------------|--------------|-----------------|
| TMC3033R2C30 | 30 Msps | T _A = 0°C to 70°C | Commercial | 44-Lead PLCC | 3033R2C30 |
| TMC3033R2C50 | 50 Msps | T _A = 0°C to 70°C | Commercial | 44-Lead PLCC | 3033R2C50 |
| TMC3033R2C80 | 80 Msps | T _A = 0°C to 70°C | Commercial | 44-Lead PLCC | 3033R2C80 |
| TMC3033KRC30 | 30 Msps | T _A = 0°C to 70°C | Commercial | 48-Lead LQFP | 3033KRC30 |
| TMC3033KRC50 | 50 Msps | T _A = 0°C to 70°C | Commercial | 48-Lead LQFP | 3033KRC50 |
| TMC3033KRC80 | 80 Msps | T _A = 0°C to 70°C | Commercial | 48-Lead LQFP | 3033KRC80 |

DISCLAIMER

FAIRCHILD SEMICONDUCTOR RESERVES THE RIGHT TO MAKE CHANGES WITHOUT FURTHER NOTICE TO ANY PRODUCTS HEREIN TO IMPROVE RELIABILITY, FUNCTION OR DESIGN. FAIRCHILD DOES NOT ASSUME ANY LIABILITY ARISING OUT OF THE APPLICATION OR USE OF ANY PRODUCT OR CIRCUIT DESCRIBED HEREIN; NEITHER DOES IT CONVEY ANY LICENSE UNDER ITS PATENT RIGHTS, NOR THE RIGHTS OF OTHERS.

LIFE SUPPORT POLICY

FAIRCHILD'S PRODUCTS ARE NOT AUTHORIZED FOR USE AS CRITICAL COMPONENTS IN LIFE SUPPORT DEVICES OR SYSTEMS WITHOUT THE EXPRESS WRITTEN APPROVAL OF THE PRESIDENT OF FAIRCHILD SEMICONDUCTOR CORPORATION. As used herein:

1. Life support devices or systems are devices or systems which, (a) are intended for surgical implant into the body, or (b) support or sustain life, or (c) whose failure to perform when properly used in accordance with instructions for use provided in the labeling, can be reasonably expected to result in significant injury to the user.
2. A critical component is any component of a life support device or system whose failure to perform can be reasonably expected to cause the failure of the life support device or system, or to affect its safety or effectiveness.

Copyright © Each Manufacturing Company.

All Datasheets cannot be modified without permission.

This datasheet has been download from :

www.AllDataSheet.com

100% Free DataSheet Search Site.

Free Download.

No Register.

Fast Search System.

www.AllDataSheet.com