

TQ5631

DATA SHEET

3V PCS Band CDMA RFA/Mixer IC

Features

- Small size: SOT23-8
- Single 3V operation
- Low-current operation
- Gain Select
- High IP3 performance
- Few external components

Applications

- IS-95 CDMA Mobile Phones

Product Description

The TQ5631 is a 3V, RF Amplifier/Mixer IC designed specifically for PCS band CDMA applications. Its RF performance meets the requirements of products designed to the IS-95 standards. The TQ5631 is designed to be used with the TQ3631 (CDMA LNA) which provides a complete CDMA receiver for 1900MHz phones.

The RFA/Mixer incorporates on-chip switches which determine gain select states. When used with the TQ3631 (CDMA LNA), four gain steps are available. The RF input port is internally matched to 50 Ω , greatly simplifying the design and keeping the number of external components to a minimum. The TQ5631 achieves good RF performance with low current consumption, supporting long standby times in portable applications. Coupled with the very small SOT23-8 package, the part is ideally suited for PCS band mobile phones.

Electrical Specifications¹

Parameter	Min	Typ	Max	Units
Frequency		1960		MHz
Gain		15.0		dB
Noise Figure		5.7		dB
Input 3 rd Order Intercept		1.0		dBm
DC supply Current		20.0		mA

Note 1: Test Conditions: Vdd=2.8V, RF=1960MHz, LO=1750MHz, IF=210MHz, Ta=25C, LO input -4dBm, CDMA High Gain state.



TQ5631

Data Sheet

Electrical Characteristics

Parameter	Conditions	Min.	Typ/Nom	Max.	Units
RF Frequency	PCS band	1800	1960	2200	MHz
IF Frequency		100	210	300	MHz
LO Frequency		1600	1750	2300	MHz
CDMA Mode-High Gain					
Gain		12.2	15.0		dB
Noise Figure			5.7	6.8	dB
Input IP3		-1.0	1.0		dBm
Supply Current			20.0	25.5	mA
CDMA Mode-High Gain Low Linearity					
Gain		17.0	21.0		dB
Noise Figure			5.3		dB
Input IP3			-3.0		dBm
Supply Current			20.0		mA
CDMA Mode-Mid Gain					
Gain		1.0	3.0		dB
Noise Figure			12.0		dB
Input IP3			18.0		dBm
Supply Current			15.0		mA
CDMA Mode-Low Gain					
Gain		6.2	8.0		dB
Noise Figure			10.0		dB
Input IP3			13.5		dBm
Supply Current			15.0		mA
Supply Voltage		2.7	2.8	2.9	V

Note 1: Test Conditions: $V_{dd}=2.8V$, $RF=1960MHz$, $LO=1750MHz$, $IF=210MHz$, $T_c = 25^\circ C$, LO input $-4dBm$, unless otherwise specified.

Note 2: Min/Max limits are at $+25^\circ C$ case temperature, unless otherwise specified.

Absolute Maximum Ratings

Parameter	Value	Units
DC Power Supply	5.0	V
Power Dissipation	500	mW
Operating Temperature	-30 to 85	C
Storage Temperature	-60 to 150	C
Signal level on inputs/outputs	+20	dBm
Voltage to any non supply pin	+0.3	V

TQ5631

Data Sheet

Typical Performance, Note:HG=High Gain, LL=High Gain Low Linearity, LG=Low Gain

Test Conditions, unless otherwise specified: $V_{dd}=2.8V$, $T_a=25C$, $R_F=1960MHz$, $LO=1750MHz$, $I_F=210MHz$, $LO\ input=-4dBm$,

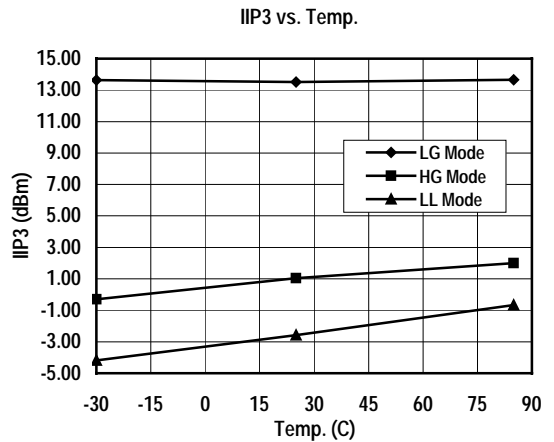
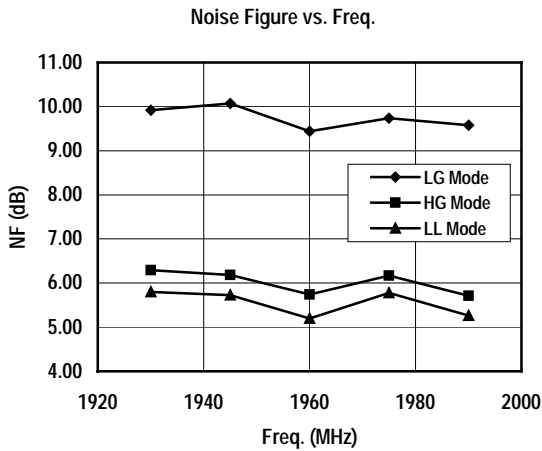
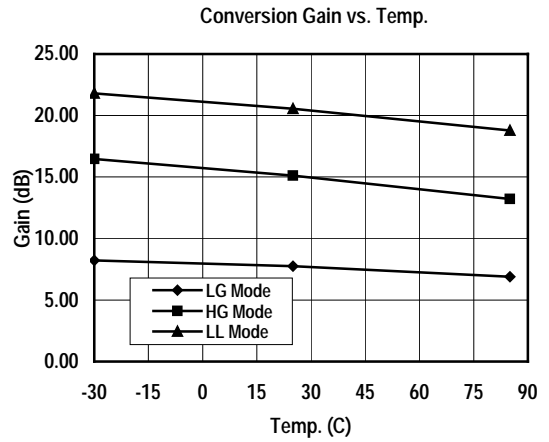
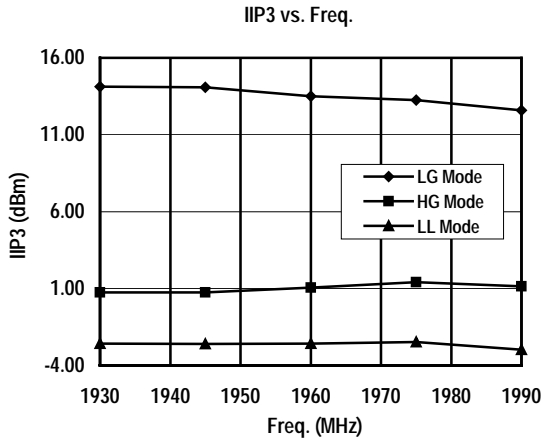
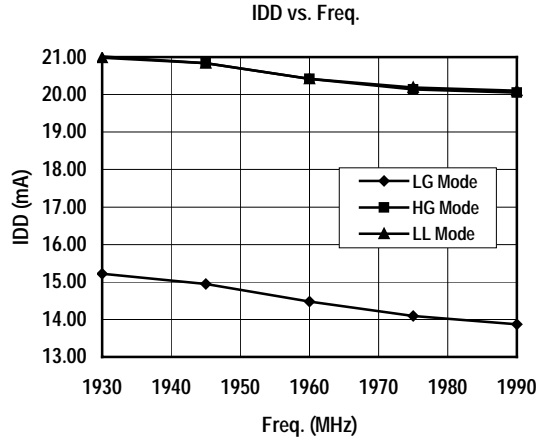
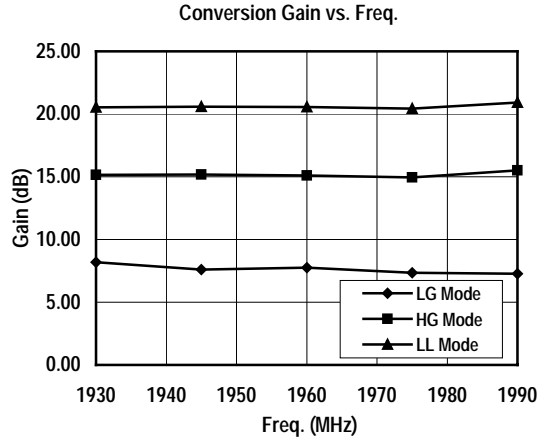

TQ5631

Data Sheet

Noise Figure vs. Temp.

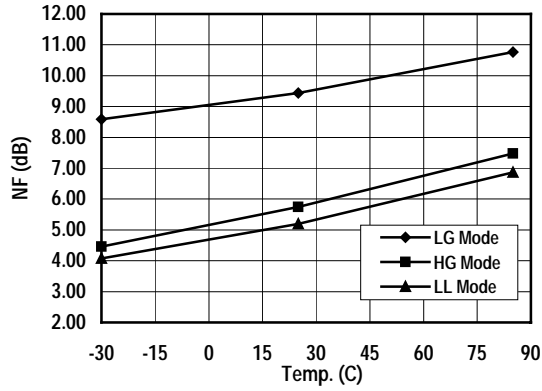

IIP3 vs. LO Power

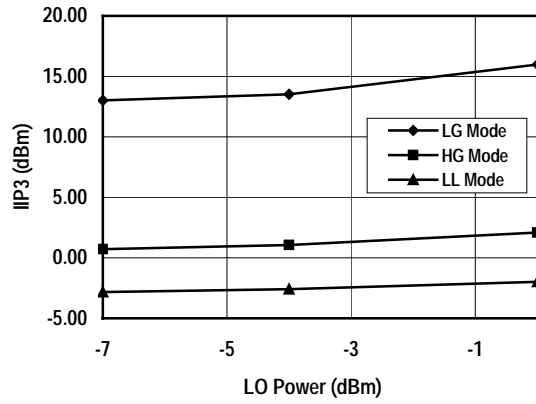

IDD vs. Temp.

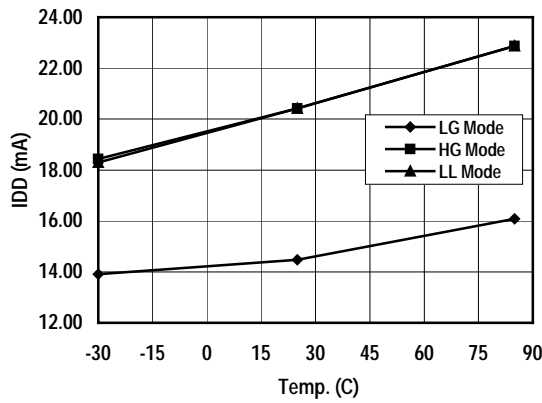

Noise Figure vs. LO Power

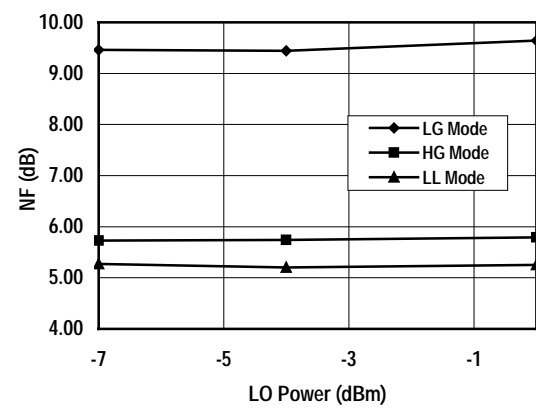

Conversion Gain vs. LO Power

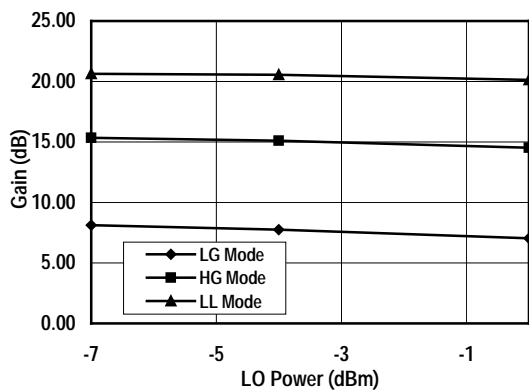

IDD vs. LO Power

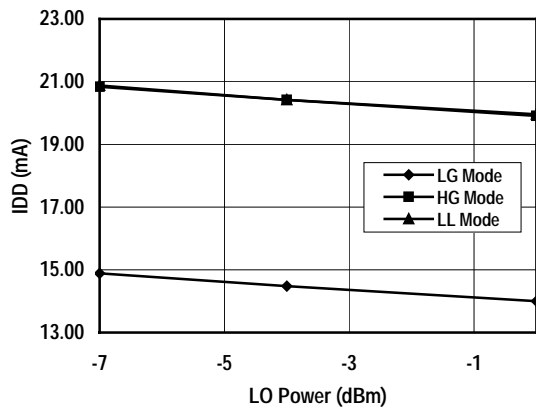

TQ5631

Data Sheet

Conversion Gain vs. VDD

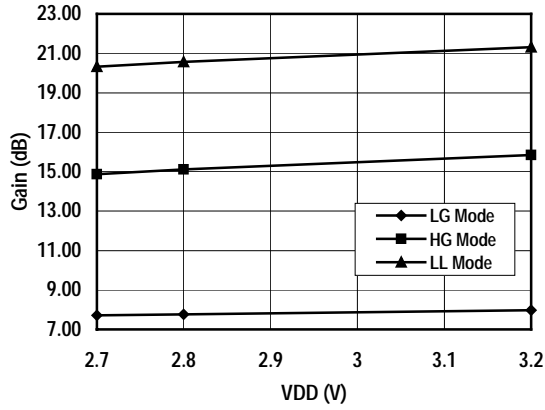

IDD vs. VDD

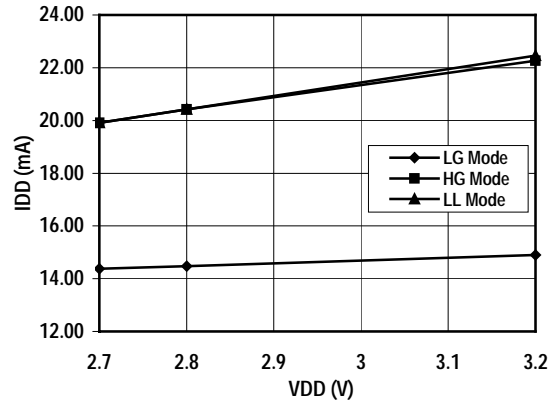

IIP3 vs. VDD

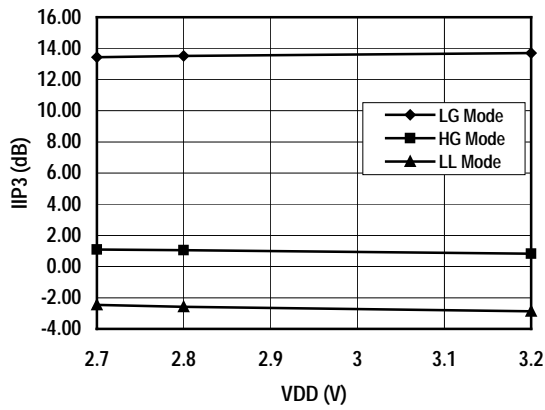

Noise Figure vs. VDD

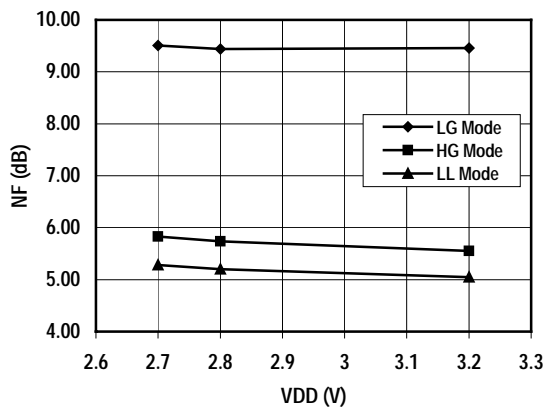

TQ5631

Data Sheet

Application/Test Circuit

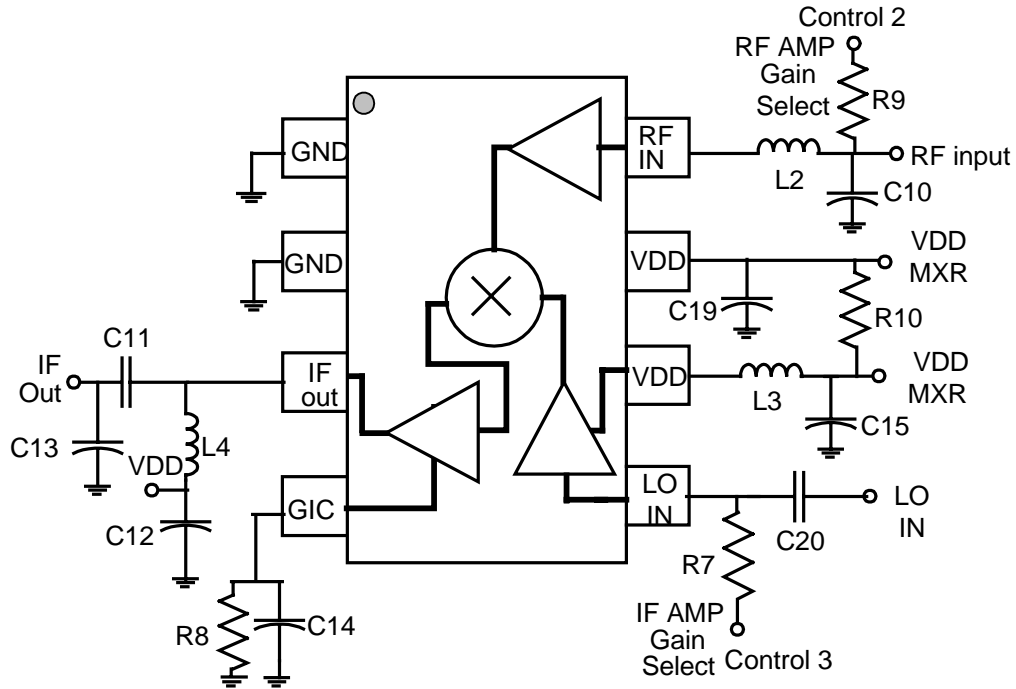

Bill of Material for TQ5631 RF AMP/Mixer

Component	Reference Designator	Part Number	Value	Size	Manufacturer
Receiver IC	U1	TQ5631		SOT23-8	TriQuint Semiconductor
Capacitor	C11		22pF	0402	
Capacitor	C12, C14, C15, C19		1000pF	0402	
Capacitor	C13		12pF	0402	
Capacitor	C10		1.5pF	0402	
Capacitor	C20		68pF	0402	
Resistor	R8		27Ω	0402	
Resistor	R7, R9		5.1KΩ	0402	
Resistor	R10		20Ω	0402	
Inductor	L2		2.7nH	0402	Panasonic
Inductor	L3		4.7nH	0402	Panasonic
Inductor	L4		56nH	0603	Panasonic
Filter	U2	L2XB			Fijitsu

TQ5631 Data Sheet

TQ5631 Product Description

Simplified theory of operation

The TQ5631 contains an RF amp, mixer, IF amp, and RF switches. Pin count is reduced by doubling the function of several pins, where dc control bias and RF signal are present at the same time. (Figure 1)

In the low gain modes, the RF amp is disabled and the the input signal is routed directly to the mixer. In the high gain modes, a cascode amp is switched in before the mixer. Control for this function is made via a dc signal on the RF input pin 8. A number of switches are used internally to eliminate any parasitic signal paths.

The IF amp gain can be stepped as well via a control line at pin 5. The general IF amp gain and current draw can be set using external components at the GIC pin 4.

The TQ5631 uses an off chip inductor with a bypass capacitor at pin 6 for tuning the LO buffer. Although the device can be connected directly to 50Ω at the RF input, a better match is obtained by using a small series inductor and shunt capacitor at the RF input.

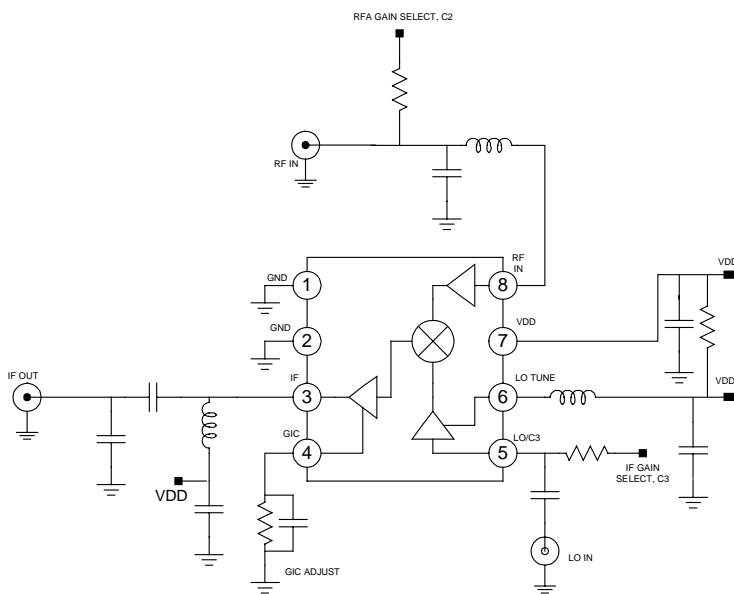

FIGURE 3
TQ5631 SIMPLIFIED CIRCUIT

Logic truth table and logic control functions

TABLE 1		TRUTH TABLE			
CONTROL LINES					
Receiver	RFA Gain	IFA Gain	LNA	Mixer State	
Mode	Select	Select	State	RFA	IFA
	C2	C3			
CDMA HG	0	0	HG CDMA Idd	HG	LG
CDMA HGLL	0	1	HG Low Idd	HG	HG
CDMA MG	1	0	HG CDMA Idd	Bypassed	LG
CDMA LG	1	1	Bypassed	Bypassed	HG

HG=High Gain; HGLL=High Gain Low Linearity; MG=Mid Gain; LG=Low Gain

TABLE 1

When used in conjunction with the TQ3631, the TQ5631 down convert mixer can be set to a variety of different gain states. This allows the receiver (LNA + downconvert mixer) to operate with a wide dynamic range, while optimizing current draw and overall receiver performance.

Two external control lines set the LNA + downconverter into any one of the four states, described below.

- CDMA Low Gain Mode: This mode is selected in very high signal environment. The current draw in this case is 16mA for the receive chain.
- CDMA High Gain Mode: This mode is selected in very weak signal environment. The receiver is in it's maximum sensitivity.
- CDMA High Gain Low Linearity Mode: This mode is selected when the phone is in standby mode. The phone power amplifier will be off in this state, removing the possibility of self jamming.
- CDMA Mid Gain Mode. This mode is selected in a medium signal strength environment.

DOWNCONVERTER APPLICATION HINTS:

Printed Circuit Board Layout guidelines for stability

With good layout practices the circuit will be stable. However, poor layout may lead to oscillation problems. Good grounding is especially important for the TQ5631 since it uses an off-chip LO

TQ5631

Data Sheet

tuning inductor which provides a potential ground loop path. One could use the evaluation board as an example of proper layout techniques.

It is important to position the LO tuning and the GIC components as close to the chip as possible. If the components are placed too far from the chip the PC board traces can act as quarter wave resonators in the 5-10GHz region. If both the GIC and the LO paths to ground resonate at the same frequency, oscillation can result, especially if Q is very high.

It is most important that the ground on the GIC bypass cap, the LO tuning bypass capacitor, and the IF shunt cap return back to chip pins 1 and 2 with minimal inductance. This requires that ground returns utilize vias at a number of locations.

Solid grounding of the LO tuning inductor and bypass capacitor will result in higher tuning circuit Q. The higher the Q, the greater the LO drive to the mixer will be and IIP3 performance will also improve with higher Q.

LO Buffer Tuning

Because of the broadband input match of the LO buffer amplifier, thermal and induced noise at other frequencies can be amplified and injected directly into the LO port of the mixer. Noise at the IF frequency, and at LO +/- IF will be downconverted and emerge at the IF port, degrading the downconverter noise figure.

For maximum flexibility the high band TQ5631 device has the output node of the LO buffer amplifier brought out to Pin 6. By connecting an external inductor between the pin and Vdd, LO tuning can be varied. This inductor is selected to resonate with internal capacitance at the LO frequency in order to roll off out-of-band gain and improve noise performance. This approach allows selectivity in the LO buffer amplifier along with the ability to use the TQ5631 with multiple IF's.

Calculation of Nominal L Value

The proper inductor value must be determined during the design phase. The internal capacitance at Pin 6 is approximately 1.6 pF. Stray capacitance on the board surrounding Pin 6 will add to the internal capacitance, so the nominal value of inductance can be calculated, but must be confirmed with measurements on a board approximating the final layout (see Figure 2). Additionally, there is already approximately 1.3nH of inductance

from the die out to the pin which must be subtracted off of the needed inductance value.

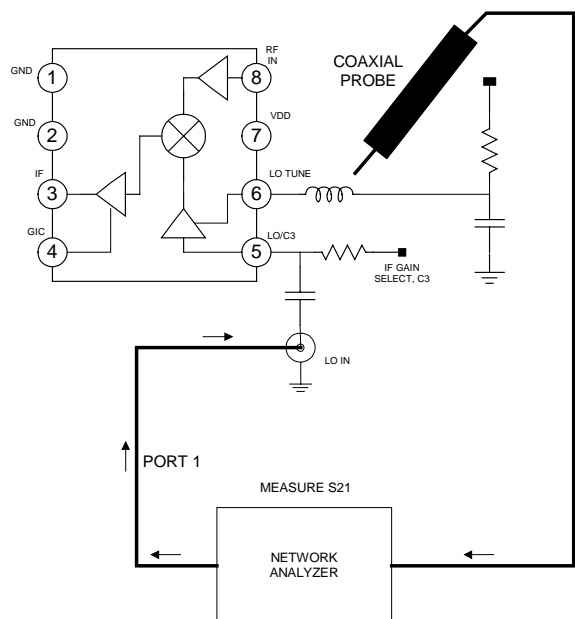

Figure 2 LO Tuning Setup

The inductor is selected that would resonate with the total capacitance at the LO frequency using the following equation:

$$L = \frac{1}{C(2\pi F)^2} - 1.3nH \quad \text{where } C=1.6pF$$

To fine tune the LO, two methods have been proven to work well:

- a) Select the inductance (next standard value) which is higher than the calculated value derived from the equation above. Then select a bypass capacitor that forms a resonant circuit with the inductor. The bypass capacitor can be used to fine tune the resonant frequency.
- b) The second method relies on moving the bypass capacitor relative to the tuning inductor. This varies the amount of inductance in the circuit and provides a means to fine tune the LO. This method is utilized on the test boards.

Verification of Proper LO Buffer Amp Tuning

Using a Network Analyzer

Connect port 1 to the LO input (Pin 5) of the TQ5631 with the source power set to deliver -4 dBm. Connect the coaxial probe to Port 2 and place the probe tip approximately 0.1 inch away from the inductor. The magnitude of S21 represents the LO buffer frequency response (figure 3). The test can be done in any of the CDMA modes, but both the rf and IF ports should be terminated to 50 ohms.

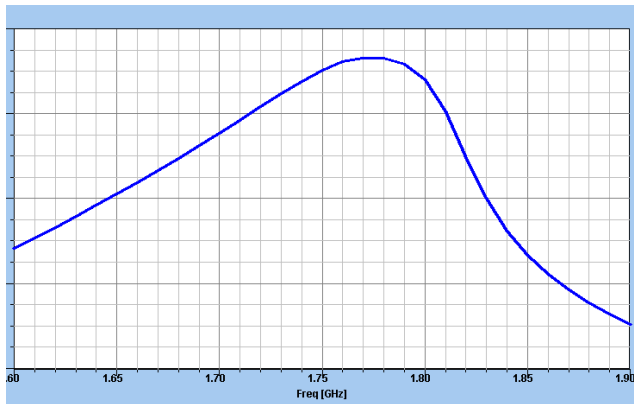

Figure 3 LO Buffer Response

The absolute value isn't important, since it depends on the probe's distance from the pin (it is usually around -30 dB), but the peak of the response should be centered in the slightly to the right of the LO frequency band center, in this case 1750MHz. Increasing the inductance will lower the center frequency, and vice versa. Try to keep the probe away from the LO input as it will interfere with the measurement.

We have found experimentally that optimum mixer performance is achieved when the LO is tuned slightly higher than the band center. Additionally, since the curve is much steeper on the high-side of the LO tuning curve, it is best to tune the device to a slightly higher frequency to ensure that the application is never operated in that region of the curve. Small variations in the application circuit due to inductor tolerances and pc board trace capacitance will then have less affect on the circuit.

Lower than expected IIP3 is the major symptom of improper LO tuning in an application. The internal passive mixer FET needs some minimum LO voltage at its gate in order to achieve satisfactory IP3, which does not occur if the LO is untuned.

Half IF Spur Rejection Considerations

Because the TQ5631 does not contain a balanced mixer, Half IF spur rejection is completely set by the image filter. Thus we do not recommend using an IF that is less than 2.5 times the bandwidth of the image filter.

Downconverter IF Match Design

The Mixer IF output (pin 3) is an "open-drain" configuration, allowing for flexibility in efficient matching to various filter types and at various IF frequencies. An optimum lumped-element matching network must be designed for maximum power gain and output third order intercept.

When designing the IF output matching circuit, one has to consider the output impedance (pin 3) of the IF Amplifier. It will vary somewhat depending on the quiescent current, which is set with the GIC pin. The IF frequency can be tuned from 100 to 300 MHz by varying component values of the IF output matching circuit. The IF output pin also provides the DC bias for the output FET's.

In the user's application, the IF output is most commonly connected to a narrowband SAW or crystal filter with impedance from 300 -1000Ω with 1 - 2 pF of capacitance. A conjugate match to a higher filter impedance is generally less sensitive than matching to 50Ω. When verifying or adjusting the matching circuit on the prototype circuit board, the LO drive should be injected at the nominal power level (-4 dBm), since the LO level does have an impact on the IF port impedance.

Suggested Matching Networks

There are several networks that can be used to properly match the IF port to the SAW or crystal IF filter. The IF FET current is applied through the IF output pin 3, so the matching circuit topology must contain either an RF choke or shunt inductor as shown in Figure 4.

For purposes of evaluation, the shunt L, series C, shunt C circuit shown below is the simplest and requires the fewest components. DC current can be easily injected through the shunt inductor and the series C provides a DC block, if needed. The shunt C, in particular can be used to improve the return loss and to reduce the LO leakage. Generally the shunt C should be equal or larger than the series C. Furthermore, for best stability,

TQ5631

Data Sheet

the ground end of the shunt cap should be as close to the chip ground as is possible.

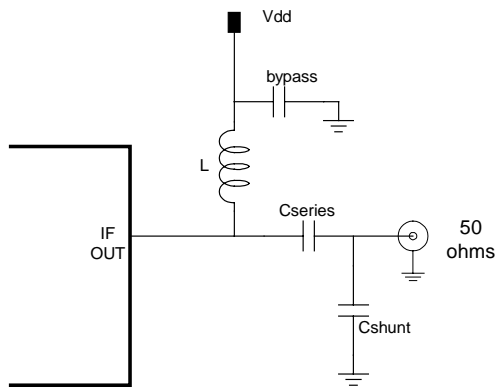

Figure 4 IF Output Match

GIC Component Selection

The GIC pin on the TQ5631 is connected internally to the source of the IF output stage. By adding two resistors and a capacitor to this pin, it is possible to vary both the IF stage AC gain, and the IF stage quiescent current. However, there is a limit to the amount of gain increase that is possible, since there always exists some package and bond wire inductance back to the die. Furthermore, although some additional IP3 performance may be gained by increasing the quiescent current, in practice it makes no sense to increase Idd beyond that which provides maximum input intercept. At some point IP3 is limited by the mixer FET, and no further increase in input intercept can be obtained by adjusting the IF stage.

There are two GIC schemes that are recommended for the CDMA devices (Figure 5). The first uses a small resistor in series with a larger bypassed resistor. The AC gain is set by the unbypassed resistor, while the DC IF current is then set by the sum of the two resistors.

The second scheme, which is recommended for the high band device, uses a resistor in parallel with a series combination of resistor and capacitor. The first resistor sets the DC current, while the equivalent parallel resistance sets the AC gain. The presence of a resistor directly from the GIC pin to ground tends to dampen the Q of any resonance in the 5-10ghz range which might be formed by the GIC circuitry.

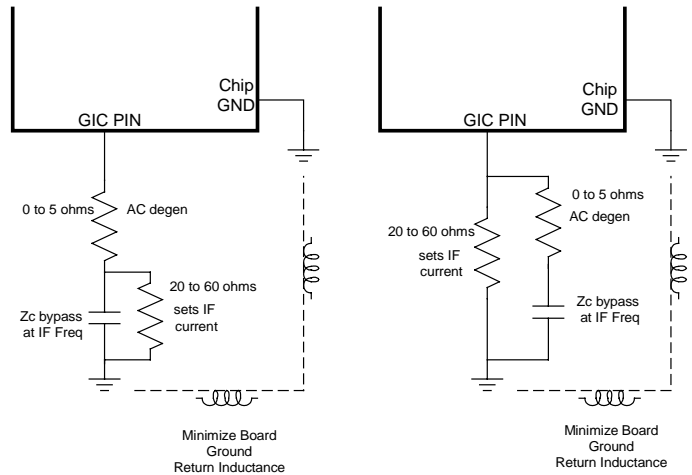

Figure 5 GIC Pin Networks

The Image Filter to Mixer RF input Path

We recommend evaluating the CDMA downconverter by considering it and the image filter as a block, since there is a very complicated non-linear interaction between the mixer and image filter. Especially in the LG and MG receiver modes, some LO energy leaks out through the RF input, reflects off the image filter, and then returns back into the mixer (Figure 6).

The reflection at the filter occurs because most SAW and dielectric filters look like a short circuit outside of the passband. Depending on the phase of the reflected signal, noise figure, gain, and IP3 can be negatively affected. Thus system simulation can be inaccurate if the downconverter and filter are treated separately.

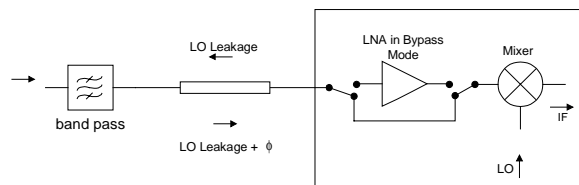

Figure 6 Mixer-Filter Interaction

The issue also raises a dilemma with regard to the specification of SSB noise figure. An image filter is needed for measurement; yet how does one go about specifying the SSB noise figure (CG

and IIP3 as well) of the downconverter alone, realizing that it depends somewhat upon the type of image filter used and the delay between it and the mixer? The most pragmatic approach measures the NF, CG, and IIP3 with the filter in place. The downconverter to filter distance(in pS) is set to be similar to that which would be used in the end application. Then filter I.L. is simply subtracted off of the system noise figure in order to arrive at the downconverter NF. Similarly, the filter I.L. is subtracted off of the IIP3 and added to the CG in order to arrive at those numbers.

Use correct RF input power levels for accurate test results

Because the CDMA devices have a number of gain states, it important to make sure that IP3 measurements are not taken in a state of compression. Additionally, using too low of a power puts the IMD products too close to the noise floor for accurate results.

Figure 7 shows the automated test setup that is used for evaluation. Table 2 lists the RF input powers that we are using to evaluate the devices, which has proved to be effective for automated measurement. For bench measurement, it is possible to use much lower input powers, since no hardware routines are needed for peak searching.

RF Input Power (dBm)		
Mode		Downconverter plus Filter
CDMA HGLL		-20
CDMA HG		-20
CDMA MG		-5
CDMA LG		-10

Table 2 Suggested RF Input Test Levels

TQ5631

Data Sheet

Package Pinout

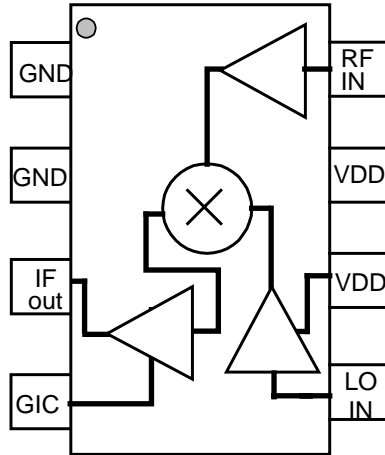

Pin Descriptions

Pin Name	Pin #	Description and Usage
GND	1	Ground
GND	2	Ground
IF OUT	3	IF Output and IF Vdd
GIC	4	Off chip tuning for gain/IP3/current
LO IN	5	LO Input, and Control 3 input
VDD	6	LO Buffer Vdd
VDD	7	Mixer Vdd
RF IN	8	RF input, and Control 2 input

Package Type: SOT23-8 Plastic Package

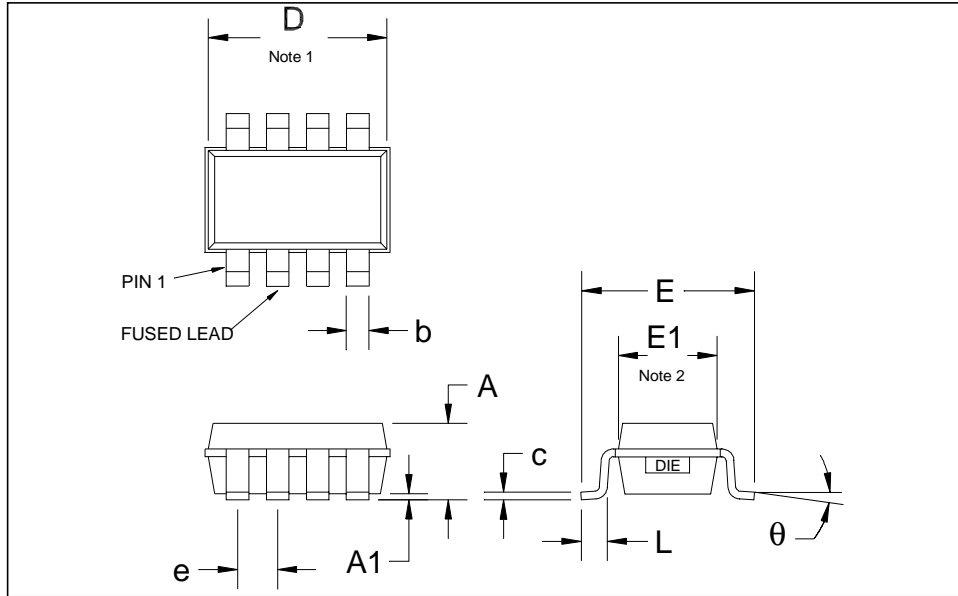

DESIGNATION	DESCRIPTION	METRIC	ENGLISH	NOTE
A	OVERALL HEIGHT	1.20 +/- .25 mm	0.05 +/- .250 in	3
A1	STANDOFF	.100 +/- .05 mm	.004 +/- .002 in	3
b	LEAD WIDTH	.365 mm TYP	.014 in	3
c	LEAD THICKNESS	.127 mm TYP	.005 in	3
D	PACKAGE LENGTH	2.90 +/- .10 mm	.114 +/- .004 in	1,3
e	LEAD PITCH	.65 mm TYP	.026 in	3
E	LEAD TIP SPAN	2.80 +/- .20 mm	.110 +/- .008 in	3
E1	PACKAGE WIDTH	1.60 +/- .10 mm	.063 +/- .004 in	2,3
L	FOOT LENGTH	.45 +/- .10 mm	.018 +/- .004 in	3
Theta	FOOT ANGLE	1.5 +/- 1.5 DEG	1.5 +/- 1.5 DEG	

Notes

1. The package length dimension includes allowance for mold mismatch and flashing.
2. The package width dimension includes allowance for mold mismatch and flashing.
3. Primary dimensions are in metric millimeters. The English equivalents are calculated and subject to rounding error.

TQ5631
Data Sheet

Additional Information

For latest specifications, additional product information, worldwide sales and distribution locations, and information about TriQuint:

Web: www.triquint.com

Tel: (503) 615-9000

Fax: (503) 615-8900

For technical questions and additional information on specific applications:

The information provided herein is believed to be reliable; TriQuint assumes no liability for inaccuracies or omissions. TriQuint assumes no responsibility for the use of this information, and all such information shall be entirely at the user's own risk. Prices and specifications are subject to change without notice. No patent rights or licenses to any of the circuits described herein are implied or granted to any third party.

TriQuint does not authorize or warrant any TriQuint product for use in life-support devices and/or systems.

Copyright © 1998 TriQuint Semiconductor, Inc. All rights reserved.

Revision A, March, 2000