

DAB One-Chip Channel- and Source / Data Decoder



Description

The U2739M is an integrated circuit in advanced CMOS technology for demodulation and decoding of a DAB signal according to ETS 300 401. The channel decoder part includes the main features OFDM demodulation and time and frequency synchronization synchronization algorithms on OAK DSP core platform. The audio source decoder supports ISO MPEG 1, 2 layer II half and full sampling rate. The data decoder part is realized on the integrated OAK DSP core and includes 2 packet mode

decoders. Several standard interfaces, like I2C/L3, I2S or RDI are implemented to offer a flexible utilization. The U2739M offers a user-defined implementation of the time and frequency synchronization by down-loading the corresponding software algorithms to the OAK DSP core.

Electrostatic sensitive device.
Observe precautions for handling.



Features

- Support of mode I, II, III and IV according to ETS 300 401
- Time and frequency synchronization with a wide-range parameter set
- Optional implementation of user-defined synchronization strategy by using OAK USE-bootmode
- Flexible software configuration (set 1 – (temic kernel), set 2 – (user extension) concept)
- Automatic mode detection (AMD)
- Generation of receiver status information
- Generation of tuner control signals
- Generation of pulse width modulated VCXO control signal
- Plastic TQFP100 package or plastic LQFP144 respectively ceramic QFP144 package for software development
- Power supply 3.3 V, master clock 24.576 MHz
- Digital AFC (frequency tolerance < 0.5 Hz for mode I)
- Digital AGC with a gain control range of 40 dB
- On-chip de-interleaver memory for full 1.8 Mbit/s decoding data rate
- Time and frequency synchronization on DSP OAK core
- FIC interpreter
- Support of AIC decoding (set 2)
- Support of TII decoding and corresponding RDI insertion (set 2)

Audio Source Decoder

- Audio source decoder ISO MPEG 1, 2 layer II (ISO/IEC 11172/3)
- Half (24 kHz according ISO/IEC 13818-3) and full (48 kHz) sampling rate
- I2S and SPDIF output interfaces
- Programmable fader
- Programmable DRC

Data Decoder

- Support 2 packet mode decoder on OAK DSP core
- FIC on-chip memory, acces via MC interface
- V24/RS232 output

Channel Decoder

- Demodulation and decoding of up to 64 UEP/EEP sub-channels
- Support of dynamic multiplex reconfiguration (DMR) without mute state
- Digital Null-Symbol detection (FSYNCH generation)
- Channel filtering (48 dB)
- Optional SAW filter equilization

Interfaces

- Source decoder output interface: I2S and SPDIF
- Data decoder output interface: V24/RS232
- Channel decoder output interface: RDI and SFCO
- Microcontroller interface: I2C/L3
- RDI
 - Extended high capacity mode
 - IEC 958 format
 - RDI control channel (RCC)
- SFCO simple full capacity output
 - Window-, serial sub-channel identifier (SbChld)-, data-, error- and clock line
 - 3.072 MHz burst mode interface
- 10-bit ADC interface
 - ADC sampling clock generation
 - ADC binary or 2’s complement format selection
 - Support of several intermediate frequencies
- DSP OAK core bootstrap ROM interface
- Voltage controlled reference oscillator (VCXO) interface
- Time deinterleaver SRAM (4 Mbit) interface
- High speed serial output HSSO (PAD, DD1, DD2, CIR) interface, 3-line serial burst mode interface

Block Diagram

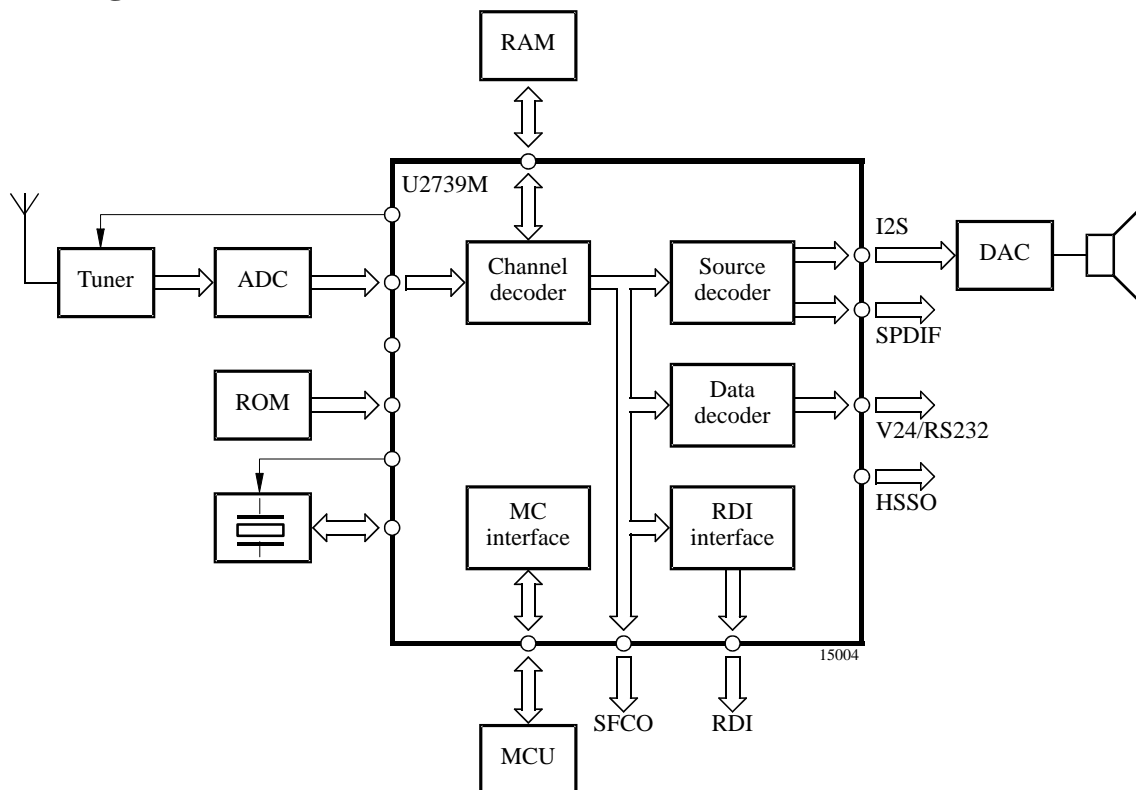

Figure 1. TEMIC DAB receiver concept

Ordering Information

Extended Type Number	Package	Remarks
U2739M	TQFP100	
U2739M	LQFP144	
U2739M	QFP144	

Package Information

Package plastic TQFP 100

Dimensions in mm

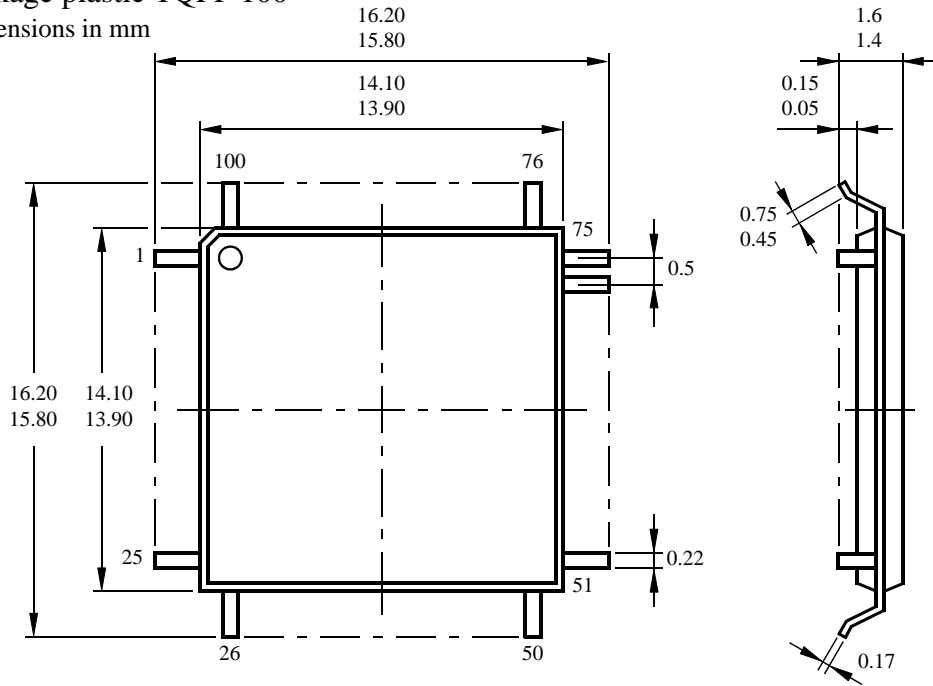

technical drawings
according to DIN
specifications

13051

Ozone Depleting Substances Policy Statement

It is the policy of **TEMIC Semiconductor GmbH** to

1. Meet all present and future national and international statutory requirements.
2. Regularly and continuously improve the performance of our products, processes, distribution and operating systems with respect to their impact on the health and safety of our employees and the public, as well as their impact on the environment.

It is particular concern to control or eliminate releases of those substances into the atmosphere which are known as ozone depleting substances (ODSs).

The Montreal Protocol (1987) and its London Amendments (1990) intend to severely restrict the use of ODSs and forbid their use within the next ten years. Various national and international initiatives are pressing for an earlier ban on these substances.

TEMIC Semiconductor GmbH has been able to use its policy of continuous improvements to eliminate the use of ODSs listed in the following documents.

1. Annex A, B and list of transitional substances of the Montreal Protocol and the London Amendments respectively
2. Class I and II ozone depleting substances in the Clean Air Act Amendments of 1990 by the Environmental Protection Agency (EPA) in the USA
3. Council Decision 88/540/EEC and 91/690/EEC Annex A, B and C (transitional substances) respectively.

TEMIC Semiconductor GmbH can certify that our semiconductors are not manufactured with ozone depleting substances and do not contain such substances.

We reserve the right to make changes to improve technical design and may do so without further notice.

Parameters can vary in different applications. All operating parameters must be validated for each customer application by the customer. Should the buyer use TEMIC products for any unintended or unauthorized application, the buyer shall indemnify TEMIC against all claims, costs, damages, and expenses, arising out of, directly or indirectly, any claim of personal damage, injury or death associated with such unintended or unauthorized use.

TEMIC Semiconductor GmbH, P.O.B. 3535, D-74025 Heilbronn, Germany
Telephone: 49 (0)7131 67 2831, Fax number: 49 (0)7131 67 2423

Copyright © Each Manufacturing Company.

All Datasheets cannot be modified without permission.

This datasheet has been download from :

www.AllDataSheet.com

100% Free DataSheet Search Site.

Free Download.

No Register.

Fast Search System.

www.AllDataSheet.com