



# Automotive Toggle Switch IC

## U6032B

### Features

- Debounce Time: 0.3 ms to 6 s
- RC Oscillator Determines Switching Characteristics
- Relay Driver with Z-diode
- Debounced Input for Toggle Switch
- Three Debounced Inputs: ON, OFF and TOGGLE
- Load-dump Protection
- RF Interference Protection
- Protection According to ISO/TR7637-1 (VDE 0839)

### Description

The bipolar integrated circuit U6032B is designed as a toggle switch. The device, which has a defined power-on status, can be used to control electrical loads, for example, fog lamps, high/low beam or heated windows for automotive applications.

Figure 1. Block Diagram with External Circuit

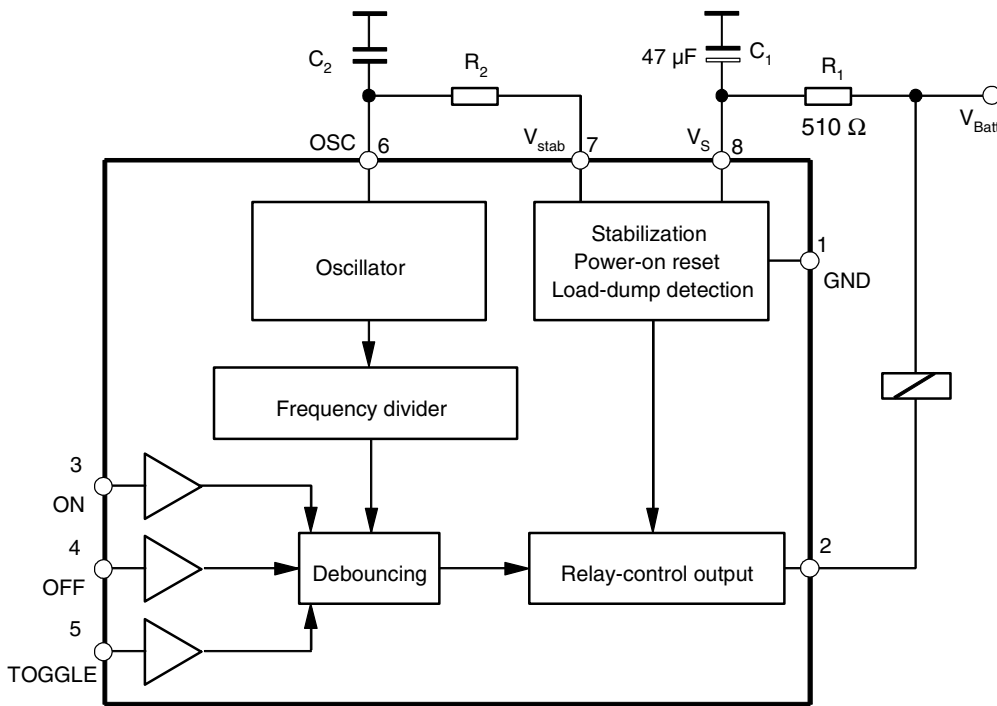

## Pin Configuration

Figure 2. Pinning DIP8/SO8

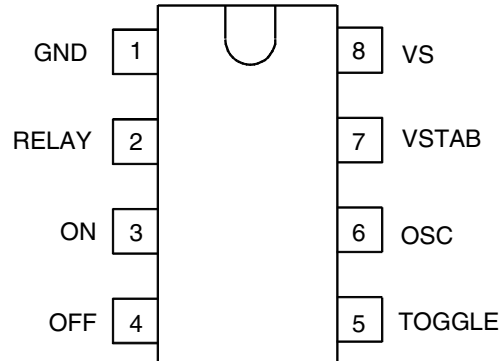

## Pin Description

Pin	Symbol	Function
1	GND	Reference point, ground
2	RELAY	Relay control output
3	ON	Switch-on input
4	OFF	Switch-off input
5	TOGGLE	Toggle input
6	OSC	RC oscillator input
7	VSTAB	Stabilized voltage
8	VS	Supply voltage

## Functional Description

### Power Supply, Pin 8

To achieve interference protection and surge immunity, the supply voltage (pin 8) must be provided with an RC circuit as shown in Figure 3. The dropping resistor,  $R_1$ , limits the current in case of overvoltage, whereas  $C_1$  smoothes the supply voltage at pin 8.

Recommended values are:  $R_1 = 510 \Omega$ ,  $C_1 = 47 \mu\text{F}$ .

An integrated Z-diode (14 V) protects the supply voltage,  $V_S$ , thus enabling stable operation in a supply-voltage range of 6 V to 16 V, supplied by  $V_{\text{Batt}}$ .

It is possible to operate the integrated circuit with a 5 V supply, but it should be assured that there are no interference voltages. In this case, pin 7 is connected to pin 8 as shown in Figure 4 on page 4, and the  $R_1C_1$  circuit is omitted.

**Figure 3.** Basic Circuit for 12-V Supply and Oscillator

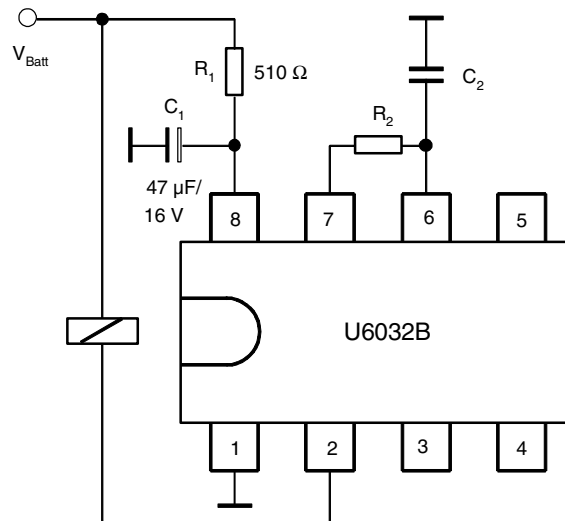

**Figure 4.** Basic Circuit for  $V_S = 5\text{ V}$

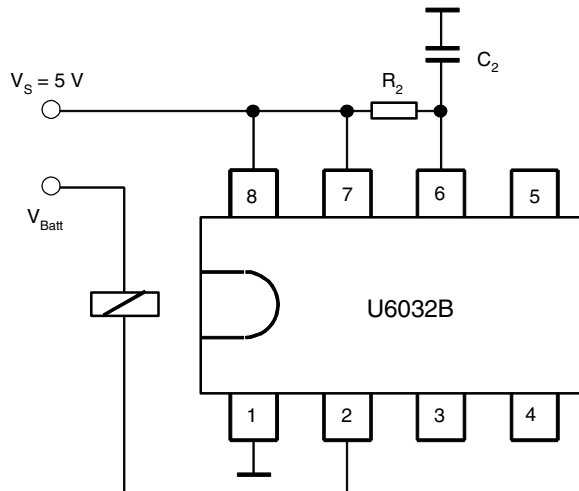

## Oscillator, Pin 6

The oscillator frequency,  $f$ , is determined mainly by the  $R_2C_2$  circuit. The resistance,  $R_2$ , determines the charge time, and the integrated resistance ( $2\text{ k}\Omega$ ) is responsible for the discharge time. To ensure the stability of the oscillator frequency, it is recommended that the selected  $R_2$  value is remarkably greater than the internal resistance ( $2\text{ k}\Omega$ ), as the temperature response and the tolerances of the integrated resistance are considerably greater than the external resistance value.

The oscillator frequency,  $f$ , is calculated as follows:

$$f = \frac{1}{t_1 + t_2}$$

where

$$t_1 = \text{charge time} = \alpha_1 \times R_2 \times C_2$$

$$t_2 = \text{discharge time} = \alpha_2 \times 2\text{ k}\Omega \times C_2$$

$\alpha_1$  and  $\alpha_2$  are constants, e.g.:

$$\alpha_1 = 0.833 \text{ and } \alpha_2 = 1.551 \text{ when } C_2 = 470\text{ pF to } 10\text{ nF}$$

$$\alpha_1 = 0.746 \text{ and } \alpha_2 = 1.284 \text{ when } C_2 = 10\text{ nF to } 4700\text{ nF}$$

The debounce time,  $t_3$ , depends on the oscillator frequency,  $f$ , as follows:

$$t_3 = 6 \times \frac{1}{f}$$

Table 1 shows the relationship between  $t_3$ ,  $C_2$ ,  $R_2$  and frequencies from 1 Hz to 20 kHz.

**Relay-control Output**

The relay-control output is an open-collector Darlington circuit with an integrated 23-V Z-diode for limiting the inductive cut-off pulse of the relay coil. The maximum static collector current must not exceed 300 mA and the saturation voltage is typically 1.1 V at 200 mA.

**Interference Voltages and Load Dump**

The IC supply is protected by  $R_1$ ,  $C_1$ , and an integrated Z-diode, while the inputs are protected by a series resistor, integrated Z-diode and RF capacitor (refer to Figure 6 on page 6).

The relay-control output is protected by the integrated 23 V Z-diode in case of short interference peaks. It is switched to conductive condition for a battery voltage greater than 40 V in case of load dump. The output transistor is dimensioned so that it can withstand the generated current.

**Power-on Reset**

When the operating voltage is switched on, an internal power-on reset pulse (POR) is generated which sets the logic of the circuits to a defined initial condition. The relay output is disabled.

**Relay-control Output Behavior, Pin 2**

The time functions (relay output) can be started or interrupted by the three inputs ON, OFF or TOGGLE (pins 3, 4 and 5, input circuit of these pins see Figure 6 on page 6).

The relay becomes active if the time function is triggered, and the relay contact is interrupted after the elapse of the delay time,  $t_d$ . There are two input possibilities.

**Toggle Input, Pin 5**

When the push-button (TOGGLE) switch,  $S_1$ , is pressed for the first time, the relay becomes active after the debounce time,  $t_3$ , i.e., the relay output, pin 2, is active.

Repeated operation of  $S_1$  causes the interruption of the relay contact, thus disabling the relay. Each operation of the toggle switch,  $S_1$ , changes (alters) the condition of the relay output when the debounce time,  $t_d$ , is exceeded, i.e., the TOGGLE function.

If the relay output is not disabled by pressing the switch  $S_1$ , the output stays active.

**Figure 5. TOGGLE Function**

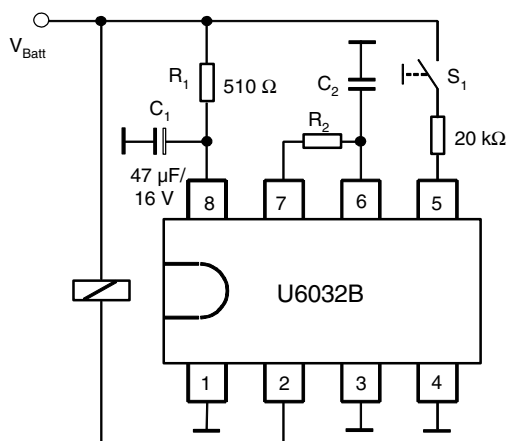

## ON, OFF Inputs, Pins 3 and 4

To avoid simultaneous operation of both inputs, pin 3 (ON) and pin 4 (OFF), the use of a two-way contact with centre-off position with spring returns (also known as rocker-actuated switch) is recommended.

Pressing the push-button switch (pin 3 ON) leads to an activation of the relay after the debounce time,  $t_3$ , has elapsed whereas the switching of pin 4 switch correspondingly leads to the de-energization of the relay. If the relay is not de-energized by the push-button switch, the output remains active.

Combined operation “TOGGLE” and “ON/OFF” is not possible due to the fact that there is only one debouncing circuit. Debouncing is possible in both modes, i.e., whenever  $S_1$  is ON or OFF.

Figure 6 shows the input circuit of U6032B. It has an integrated pull-down resistor ( $20\text{ k}\Omega$ ), RF capacitor ( $15\text{ pF}$ ) and Z-diode ( $7\text{ V}$ ). It reacts to voltages greater than  $2\text{ V}$ . The external protective resistor has a value of  $20\text{ k}\Omega$  and the push-button switch,  $S$ , is connected to the battery as shown in the diagram.

The contact current,  $I$ , is calculated as follows:

$$I = \frac{V_{\text{Batt}} - V_Z}{R(=20\text{ k}\Omega)} \quad \text{where } V_{\text{Batt}} = 12\text{ V}, V_Z = 7\text{ V}$$

$$I = \frac{(12 - 7)\text{ V}}{20\text{ k}\Omega} \approx 0.25\text{ mA}$$

It can be increased by connecting a  $5.6\text{ k}\Omega$  resistor from the push-button switch to ground as shown in Figure 8 on page 7.

**Figure 6.** Input Circuit

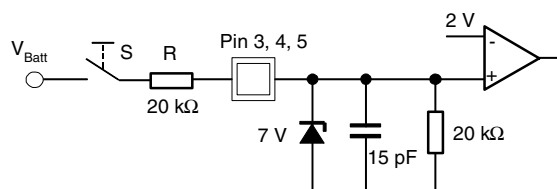

**Figure 7.** ON/OFF Function

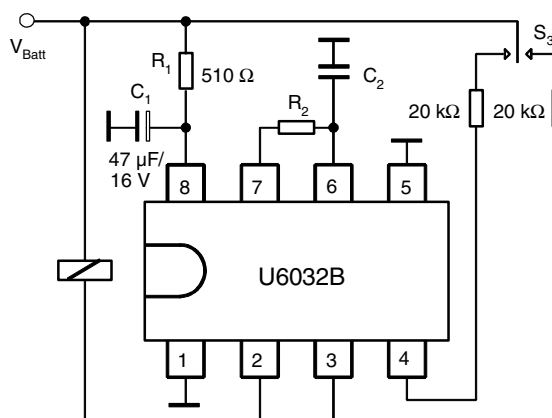

**Figure 8.** Increasing the Contact Current by Parallel Resistors

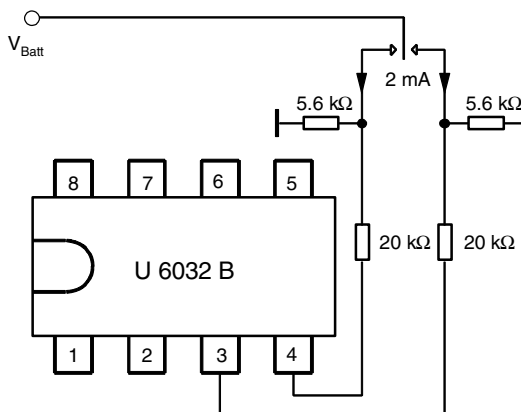

## Absolute Maximum Ratings

Stresses beyond those listed under “Absolute Maximum Ratings” may cause permanent damage to the device. This is a stress rating only and functional operation of the device at these or any other conditions beyond those indicated in the operational sections of this specification is not implied. Exposure to absolute maximum rating conditions for extended periods may affect device reliability.

Parameters	Symbol	Value	Unit
Operating voltage, static, 5 minutes	$V_{Batt}$	24	V
Ambient temperature range	$T_{amb}$	-40 to +125	°C
Storage temperature range	$T_{stg}$	-55 to +125	°C
Junction temperature	$T_j$	150	°C

## Thermal Resistance

Parameters		Symbol	Value	Unit
Junction ambient	DIP8	$T_{thJA}$	110	K/W
	SO8	$T_{thJA}$	160	K/W



## Electrical Characteristics

$V_{Batt} = 13.5\text{ V}$ ,  $T_{amb} = 25^\circ\text{C}$ , reference point ground, Figure 1 on page 1, unless otherwise specified

Parameters	Test Conditions	Pin	Symbol	Min.	Typ.	Max.	Unit
Operating voltage	$R_1 \geq 510\ \Omega$ $t < 5\text{ min}$ $t < 60\text{ min}$		$V_{Batt}$	6		16 24 18	V
5 V supply	Without $R_1$ , $C_1$	7, 8	$V_8$ , $V_7$	4.3		6.0	V
Stabilized voltage	$V_{Batt} = 12\text{ V}$	7	$V_7$	5.0	5.2	5.4	V
Undervoltage threshold	Power-on reset		$V_S$	3.0		4.2	V
Supply current	All push buttons open	8	$I_S$		1.3	2.0	mA
Internal Z-diode	$I_8 = 10\text{ mA}$	8	$V_Z$	13.5	14	16	V
<b>Relay Control Output</b>		2					
Saturation voltage	$I_2 = 200\text{ mA}$ $I_2 = 300\text{ mA}$		$V_2$		1.2	1.5	V
Leakage current	$V_2 = 14\text{ V}$		$I_{lkg}$		2	100	$\mu\text{A}$
Output current			$I_2$			300	mA
<b>Output Pulse Current</b>							
Load-dump pulse	$t \leq 300\text{ ms}$		$I_2$			1.5	A
Internal Z-diode	$I_2 = 10\text{ mA}$		$V_Z$	20	22	24	V
<b>Oscillator Input</b>		$f = 0.001\text{ to }40\text{ kHz}$ , see Table 1	6				
Internal discharge resistance	$V_6 = 5\text{ V}$		$R_6$	1.6	2.0	2.4	$\text{k}\Omega$
Switching thresholds	Lower Upper		$V_{6L}$ $V_{6H}$	0.9 2.8	1.1 3.1	1.4 3.5	V
Input current	$V_6 = 0\text{ V}$		$-I_6$			1	$\mu\text{A}$
<b>Switching Times</b>							
Debounce time			$t_3$	5		7	Cycles
<b>Inputs ON, OFF, TOGGLE</b>		3, 4, 5					
Switching threshold voltage			$V_{3,4,5}$	1.6	2.0	2.4	V
Internal Z-diode	$I_{3,4,5} = 10\text{ mA}$		$V_{3,4,5}$	6.5	7.1	8.0	V
Pull-down resistance	$V_{3,4,5} = 5\text{ V}$		$R_{3,4,5}$	13	20	50	$\text{k}\Omega$

**Table 1.** Values for  $C_2$  and  $R_2$  for a Given Oscillator Frequency and Debounce Time

Frequency $f$ (Hz)	Debounce Time $t_3$ (ms)	$C_2$ (nF)	$R_2$ ( $\text{k}\Omega$ )
1	6000	4700	280
2	3000	1000	650
3	2000	1000	440
4	1500	1000	330
5	1200	1000	260
6	1000	1000	220
7	857	1000	190
8	750	1000	160

**Table 1.** Values for  $C_2$  and  $R_2$  for a Given Oscillator Frequency and Debounce Time (Continued)

Frequency $f$ (Hz)	Debounce Time $t_3$ (ms)	$C_2$ (nF)	$R_2$ (k $\Omega$ )
9	667	1000	140
10	600	1000	130
20	300	100	650
30	200	100	440
40	150	100	330
50	120	100	260
60	100	100	220
70	86	100	190
80	75	100	160
90	67	100	140
100	60	100	130
200	30	10	600
300	20	10	400
400	15	10	300
500	12	10	240
600	10	10	200
700	9.00	10	170
800	8.00	10	150
900	7.00	10	130
1000	6.00	10	120
2000	3.00	1	600
3000	2.00	1	400
4000	1.50	1	300
5000	1.20	1	240
6000	1.00	1	200
7000	0.86	1	170
8000	0.75	1	150
9000	0.67	1	130
10000	0.60	1	120
11000	0.55	1	110
12000	0.50	1	99
13000	0.46	1	91
14000	0.43	1	85
15000	0.40	1	79
16000	0.38	1	74
17000	0.35	1	70
18000	0.33	1	66
19000	0.32	1	62
20000	0.30	1	59

## Ordering Information

Extended Type Number	Package	Remarks
U6032B	DIP8	–
U6032B-FP	SO8	–

## Package Information

### Package DIP8

Dimensions in mm

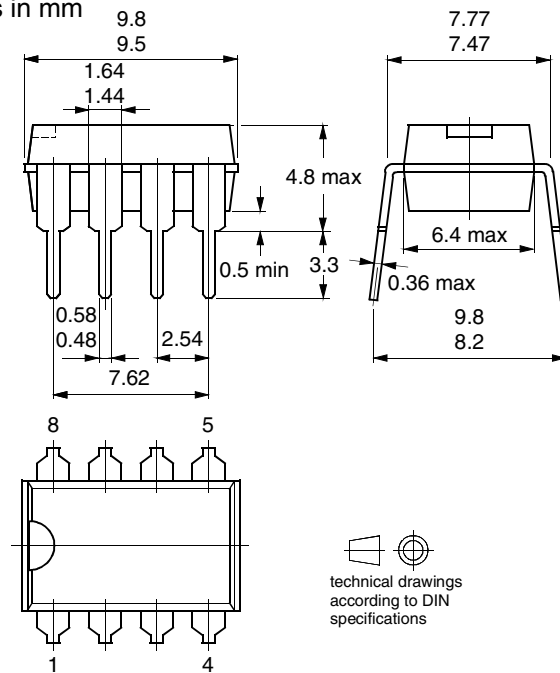

Package SO8  
Dimensions in mm

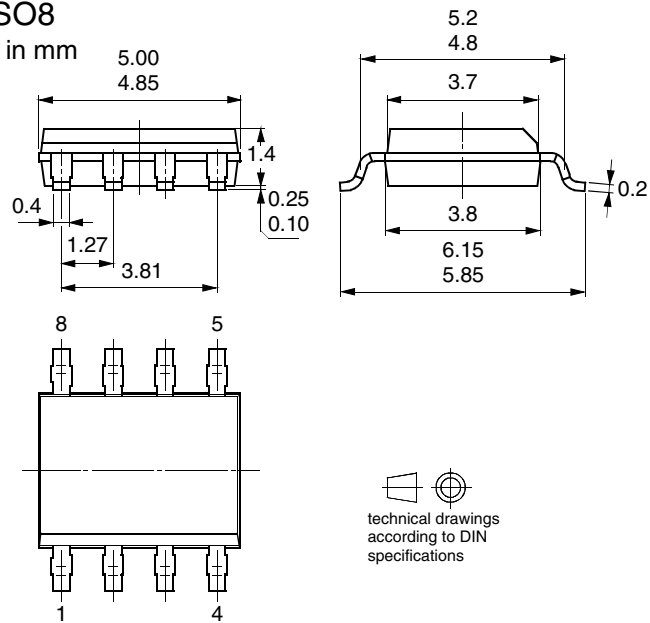



## Atmel Corporation

2325 Orchard Parkway  
San Jose, CA 95131, USA  
Tel: 1(408) 441-0311  
Fax: 1(408) 487-2600

## Regional Headquarters

### Europe

Atmel Sarl  
Route des Arsenaux 41  
Case Postale 80  
CH-1705 Fribourg  
Switzerland  
Tel: (41) 26-426-5555  
Fax: (41) 26-426-5500

### Asia

Room 1219  
Chinachem Golden Plaza  
77 Mody Road Tsimshatsui  
East Kowloon  
Hong Kong  
Tel: (852) 2721-9778  
Fax: (852) 2722-1369

### Japan

9F, Tonetsu Shinkawa Bldg.  
1-24-8 Shinkawa  
Chuo-ku, Tokyo 104-0033  
Japan  
Tel: (81) 3-3523-3551  
Fax: (81) 3-3523-7581

## Atmel Operations

### Memory

2325 Orchard Parkway  
San Jose, CA 95131, USA  
Tel: 1(408) 441-0311  
Fax: 1(408) 436-4314

### Microcontrollers

2325 Orchard Parkway  
San Jose, CA 95131, USA  
Tel: 1(408) 441-0311  
Fax: 1(408) 436-4314

La Chantrerie  
BP 70602  
44306 Nantes Cedex 3, France  
Tel: (33) 2-40-18-18-18  
Fax: (33) 2-40-18-19-60

### ASIC/ASSP/Smart Cards

Zone Industrielle  
13106 Rousset Cedex, France  
Tel: (33) 4-42-53-60-00  
Fax: (33) 4-42-53-60-01

1150 East Cheyenne Mtn. Blvd.  
Colorado Springs, CO 80906, USA  
Tel: 1(719) 576-3300  
Fax: 1(719) 540-1759

Scottish Enterprise Technology Park  
Maxwell Building  
East Kilbride G75 0QR, Scotland  
Tel: (44) 1355-803-000  
Fax: (44) 1355-242-743

### RF/Automotive

Theresienstrasse 2  
Postfach 3535  
74025 Heilbronn, Germany  
Tel: (49) 71-31-67-0  
Fax: (49) 71-31-67-2340

1150 East Cheyenne Mtn. Blvd.  
Colorado Springs, CO 80906, USA  
Tel: 1(719) 576-3300  
Fax: 1(719) 540-1759

### Biometrics/Imaging/Hi-Rel MPU/ High Speed Converters/RF Datacom

Avenue de Rochepleine  
BP 123  
38521 Saint-Egreve Cedex, France  
Tel: (33) 4-76-58-30-00  
Fax: (33) 4-76-58-34-80

---

### Literature Requests

[www.atmel.com/literature](http://www.atmel.com/literature)

**Disclaimer:** Atmel Corporation makes no warranty for the use of its products, other than those expressly contained in the Company's standard warranty which is detailed in Atmel's Terms and Conditions located on the Company's web site. The Company assumes no responsibility for any errors which may appear in this document, reserves the right to change devices or specifications detailed herein at any time without notice, and does not make any commitment to update the information contained herein. No licenses to patents or other intellectual property of Atmel are granted by the Company in connection with the sale of Atmel products, expressly or by implication. Atmel's products are not authorized for use as critical components in life support devices or systems.

© Atmel Corporation 2003. All rights reserved.

Atmel® and combinations thereof are the registered trademarks of Atmel Corporation or its subsidiaries.

Other terms and product names may be the trademarks of others.



Printed on recycled paper.

4771A-AUTO-11/03