

Features

- Temperature and Supply Voltage Compensated Flashing Frequency
- Frequency Doubling Indicates Lamp Outage
- Relay Driver Output with High Current Carrying Capacity and Low Saturation Voltage
- Minimum Lamp Load for Flasher Operation: ≥ 1 W
- Very Low Susceptibility to EMI
- Protection According to ISO/TR 7637/1 Level 4

Description

The bipolar integrated circuit U6043B is used in relay-controlled automotive flashers where a high level EMC is required.

Lamp outage is indicated by frequency doubling during hazard warning as well as direction mode.



**Flasher IC with
18-m Ω Shunt**

U6043B

Block Diagram

Figure 1. Car Flasher Application Circuit

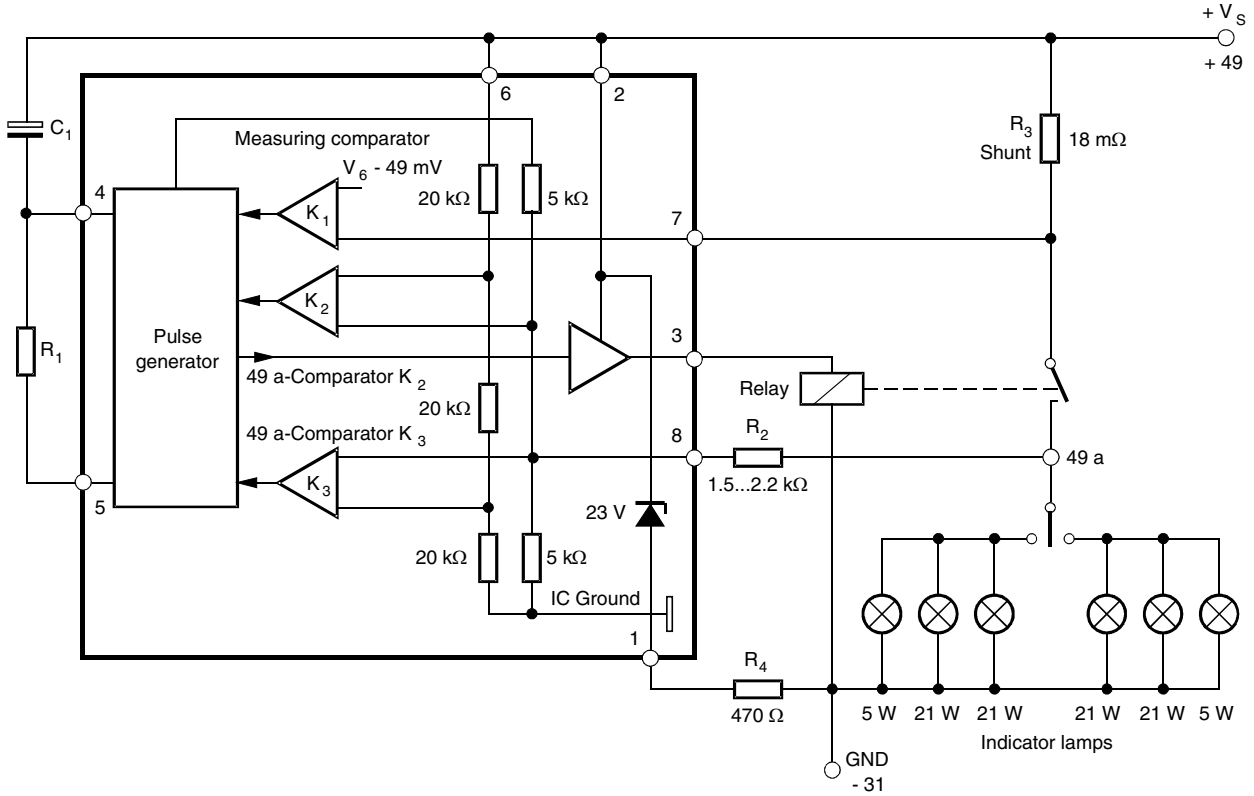

Pin Configuration

Figure 2. Pinning

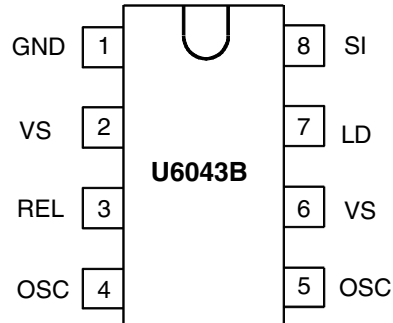

Pin Description

Pin	Symbol	Function
1	GND	IC ground
2	VS	Supply voltage
3	REL	Relay driver
4	OSC	Oscillator
5	OSC	Oscillator
6	VS	Supply voltage, Sense
7	LD	Lamp outage detection
8	SI	Start input (49a)

Functional Description

Pin 1, GND

The U6043B is protected against damage in case of battery reversal via resistor R_4 to ground (-31). An integrated protection circuit together with external resistances R_2 and R_4 limits the current pulses in the IC.

Pin 2, Supply Voltage, V_S power

The arrangement of the supply connections to Pin 2 (and 6) must be so as to ensure that on the connection printed circuit board (PCB), the resistance of V_S to Pin 6 is lower than that to Pin 2.

Pin 3, Relay Control Output (Driver)

The relay control output is a high-side driver with a low saturation voltage. It is capable of driving a typical automotive relay with a minimum coil resistance of 60 Ω .

Pin 4 and 5, Oscillator

The flashing frequency, f_1 , is determined by the R_1C_1 components as given by the following formula below (see Figure 1):

$$f_1 \approx \frac{1}{R_1 \times C_1 \times 1.5} \text{ Hz}$$

where $C_1 \leq 47 \mu\text{F}$, $R_1 = 6.8 \text{ k}\Omega$ to 510 $\text{k}\Omega$

In case of a lamp outage (see Pin 7) the oscillator frequency is switched to the lamp outage frequency f_2 with $f_2 \approx 2.2 \times f_1$.

Duty cycle in normal flashing mode: 50%

Duty cycle in lamp outage mode: 40% (bright phase)

Pin 6, Supply Voltage, Sense

For accurate monitoring via the shunt resistor, a minimized layer resistance from point V_S /shunt to Pin 6 is recommended.

Pin 7, Lamp Outage Detection

The lamp current is monitored via an external shunt resistor R_{sh} and an internal comparator K1 with its reference voltage of typ. 49 mV ($V_S = 12 \text{ V}$). The outage of one lamp is detected according to the following calculation:

Nominal current of 1 lamp: $21 \text{ W}/(V_S = 12 \text{ V})$: $I_{lamp} = 1.75 \text{ A}$

Nominal current of 2 lamps: $2 \times 21 \text{ W}/(V_S = 12 \text{ V})$: $I_{lamp} = 3.5 \text{ A}$

We recommend setting the detection threshold in the middle of the current range:

$$I_{outage} \approx 2.7 \text{ A}$$

Thus, the shunt resistor is calculated as:

$$R_{sh} = V_T(K1)/I_{outage}$$

$$R_{sh} = 49 \text{ mV}/2.7 \text{ A} = 18 \text{ m}\Omega$$

Comparator K1's reference voltage is matched to the characteristics of filament lamps (see "Control Signal Threshold" in the data part).

The combination of shunt resistor and resistance of wire harness prevents Pin 7 from a too high voltage in case of shorted lamps.

Pin 8, Start Input

Start condition for flashing: the voltage at Pin 8 has to be below the K3 threshold (flasher switch closed).

Humidity and dirt may decrease the resistance between 49 a and GND. If this leakage resistance is $> 5 \text{ k}\Omega$, the IC is still kept in the off-condition. In this case the voltage at Pin 8 is between the thresholds of comparators K2 and K3.

During the bright phase the voltage at Pin 8 is above the K2 threshold, during the dark phase it is below the K3 threshold. For proper start conditions a minimum lamp wattage of 1 W is required.

Absolute Maximum Ratings

Reference point Pin 1

Parameters		Symbol	Value	Unit
Supply voltage	Pin 2 and 6	V_S	16.5	V
Surge Forward Current				
$t_p = 0.1 \text{ ms}$	Pin 2 and 6	I_{FSM}	1.5	A
$t_p = 300 \text{ ms}$	Pin 2 and 6	I_{FSM}	1.0	A
$t_p = 300 \text{ ms}$	Pin 8	I_{FSM}	50	mA
Output current	Pin 3	I_O	0.3	A
Power Dissipation				
$T_{amb} = 95^\circ\text{C}$	DIP 8	P_{tot}	420	mW
	SO8	P_{tot}	340	mW
$T_{amb} = 60^\circ\text{C}$	DIP 8	P_{tot}	690	mW
	SO8	P_{tot}	560	mW
Junction temperature		T_J	150	$^\circ\text{C}$
Ambient temperature range		T_{amb}	-40 to +95	$^\circ\text{C}$
Storage temperature range		T_{stg}	-55 to +150	$^\circ\text{C}$

Thermal Resistance

Parameters		Symbol	Value	Unit
Junction ambient	DIP8	R_{thJA}	110	K/W
	SO8	R_{thJA}	160	K/W

Electrical Characteristics

Typical values under normal operation in application circuit (see Figure 1), V_S (+49, Pin 2 and 6) = 12 V.
Reference point ground (-31), $T_{amb} = 25^\circ\text{C}$, unless otherwise specified.

Parameters	Test Conditions	Symbol	Min.	Typ.	Max.	Unit
Supply voltage range	Pin 2 and 6	V_S	9		15	V
Supply current	Dark phase, Pin 2 and 6	I_S		4.5	8	mA
	Bright phase, Pin 2 and 6	I_S		7.0	11	mA
Relay control output: Saturation voltage Reverse current	Pin 3 $I_O = 150\text{ mA}$, $V_S = 9\text{ V}$	V_O I_O			1.0 0.1	V mA
Start delay (Delay time)	First bright phase	t_{on}			10	ms
Frequency tolerance	Normal flashing	Δf_1	-5		+5	%
Bright period	Basic frequency f_1	Δf_1	47		53	%
	Control frequency f_2	Δf_2	37		45	%
Frequency increase	Lamp outage	f_2	$2.15 \times f_1$		$2.3 \times f_1$	Hz
Control signal threshold	$V_S = 15\text{ V}$, Pin 7	V_{RS}	50	53	57	mV
	$V_S = 9\text{ V}$, Pin 7	V_{RS}	43	45	47	mV
	$V_S = 12\text{ V}$, Pin 7	V_{RS}	47	49	51	mV
Leakage resistance	49a to GND	R_P		4	5	k Ω
Lamp load		P_L	1			W

Ordering Information

Extended Type Number	Package	Remarks
U6043B	DIP8	-
U6043B-FP	SO8	-

Package Information

DIP8

Package: DIP 8
Dimensions in mm

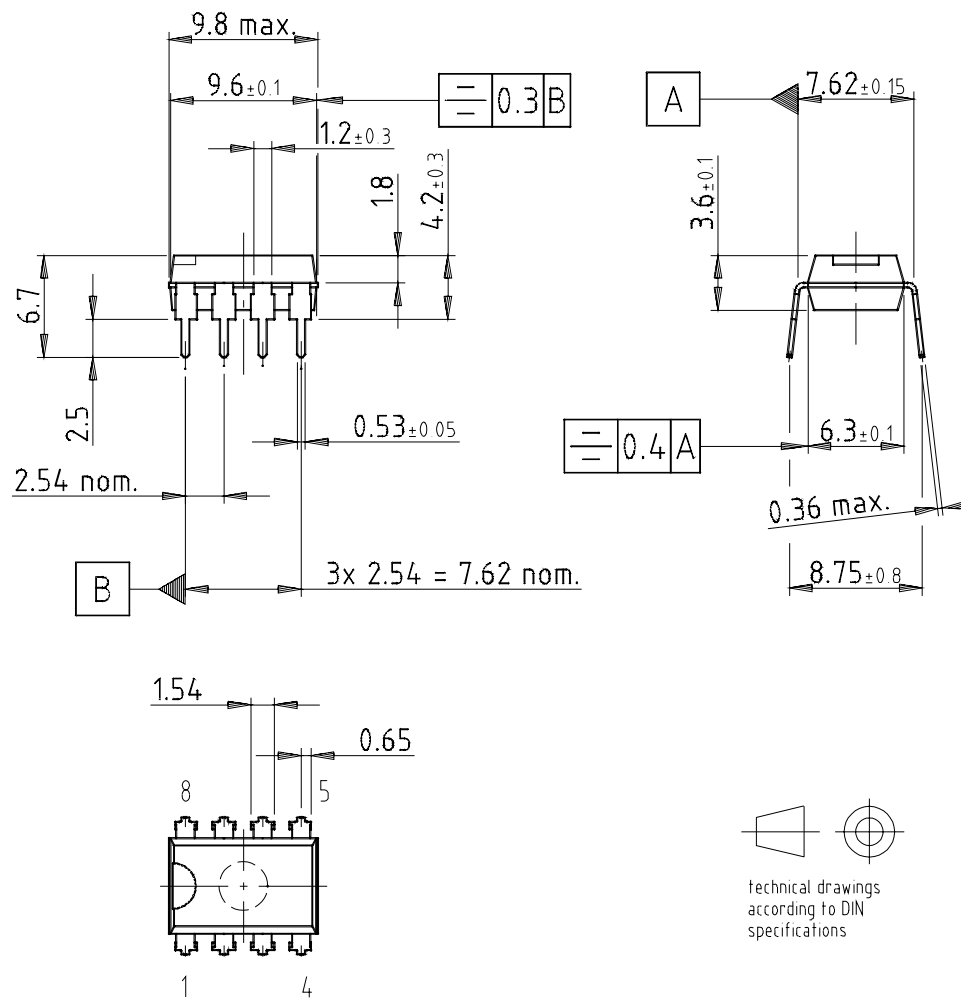

Drawing-No.: 6.543-5040.01-4
Date: 16.01.02

S08

Package S08
Dimensions in mm

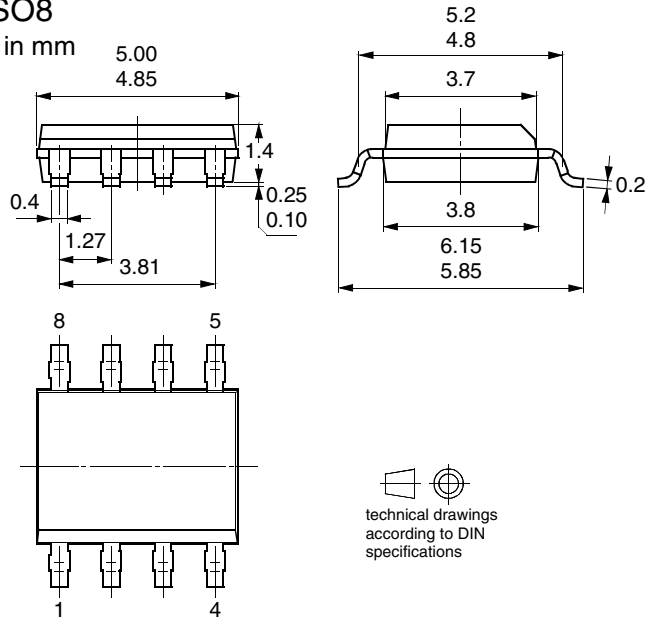



Atmel Corporation

2325 Orchard Parkway
San Jose, CA 95131
Tel: 1(408) 441-0311
Fax: 1(408) 487-2600

Regional Headquarters

Europe

Atmel Sarl
Route des Arsenaux 41
Case Postale 80
CH-1705 Fribourg
Switzerland
Tel: (41) 26-426-5555
Fax: (41) 26-426-5500

Asia

Room 1219
Chinachem Golden Plaza
77 Mody Road Tsimshatsui
East Kowloon
Hong Kong
Tel: (852) 2721-9778
Fax: (852) 2722-1369

Japan

9F, Tonetsu Shinkawa Bldg.
1-24-8 Shinkawa
Chuo-ku, Tokyo 104-0033
Japan
Tel: (81) 3-3523-3551
Fax: (81) 3-3523-7581

Atmel Operations

Memory

2325 Orchard Parkway
San Jose, CA 95131
Tel: 1(408) 441-0311
Fax: 1(408) 436-4314

Microcontrollers

2325 Orchard Parkway
San Jose, CA 95131
Tel: 1(408) 441-0311
Fax: 1(408) 436-4314

La Chantrerie
BP 70602
44306 Nantes Cedex 3, France
Tel: (33) 2-40-18-18-18
Fax: (33) 2-40-18-19-60

ASIC/ASSP/Smart Cards

Zone Industrielle
13106 Rousset Cedex, France
Tel: (33) 4-42-53-60-00
Fax: (33) 4-42-53-60-01

1150 East Cheyenne Mtn. Blvd.
Colorado Springs, CO 80906
Tel: 1(719) 576-3300
Fax: 1(719) 540-1759

Scottish Enterprise Technology Park
Maxwell Building
East Kilbride G75 0QR, Scotland
Tel: (44) 1355-803-000
Fax: (44) 1355-242-743

RF/Automotive

Theresienstrasse 2
Postfach 3535
74025 Heilbronn, Germany
Tel: (49) 71-31-67-0
Fax: (49) 71-31-67-2340

1150 East Cheyenne Mtn. Blvd.
Colorado Springs, CO 80906
Tel: 1(719) 576-3300
Fax: 1(719) 540-1759

Biometrics/Imaging/Hi-Rel MPU/ High Speed Converters/RF Datacom

Avenue de Rochepleine
BP 123
38521 Saint-Egreve Cedex, France
Tel: (33) 4-76-58-30-00
Fax: (33) 4-76-58-34-80

e-mail

literature@atmel.com

Web Site

<http://www.atmel.com>

Disclaimer: Atmel Corporation makes no warranty for the use of its products, other than those expressly contained in the Company's standard warranty which is detailed in Atmel's Terms and Conditions located on the Company's web site. The Company assumes no responsibility for any errors which may appear in this document, reserves the right to change devices or specifications detailed herein at any time without notice, and does not make any commitment to update the information contained herein. No licenses to patents or other intellectual property of Atmel are granted by the Company in connection with the sale of Atmel products, expressly or by implication. Atmel's products are not authorized for use as critical components in life support devices or systems.

© Atmel Corporation 2003. All rights reserved.

Atmel® and combinations thereof are the registered trademarks of Atmel Corporation or its subsidiaries.

Other terms and product names may be the trademarks of others.



Printed on recycled paper.