

Rear Window Heating Timer

Description

The window heating timers are bipolar integrated circuits. Due to time controlled functions, they reduce the current consumptions of high loads i.e., heating resistors.

An ON-relay can be switched off after a preset delay time. The relay time can be interrupted manually, whereas a retrigger function is not provided.

Features

- Delay time range: 3.7 s to 20 h
- RC oscillator determines switching characteristics
- Relay driver with Z-diode
- Debounced input for toggle switch
- Two debounced inputs: ON and OFF
- Load-dump protection
- RF interference protected
- Protection according to ISO/TR7637-1 (VDE 0839)
- U6046B: Inputs switched to V_{Batt}
- U6047B: Inputs switched to ground

Ordering Information

Extended Type Number	Package	Remarks
U6046B, U6047B	DIP8	
U6046B-FP, U6047B-FP	SO8	

Block Diagram

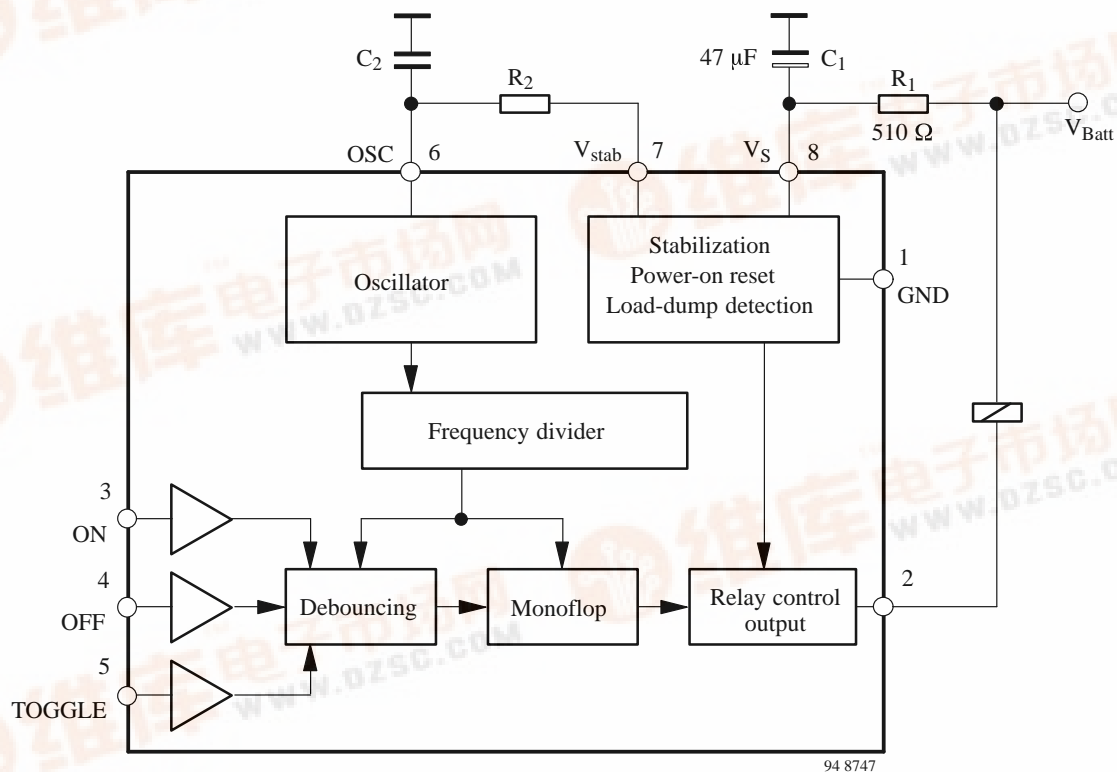

Figure 1. Block diagram with external circuit

Pin Configuration

Pin	Symbol	Function
1	GND	Reference point, ground
2	RELAY	Relay control output
3	ON	Switch-on input
4	OFF	Switch-off input
5	TOGGLE	Toggle input
6	OSC	RC oscillator input
7	V _{stab}	Stabilized voltage
8	V _S	Supply voltage

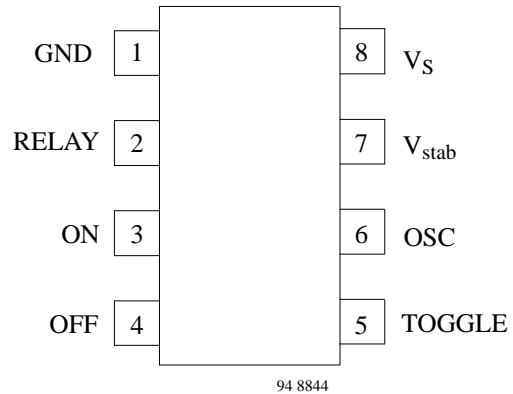

Figure 2. Pinning

Functional Description

Power Supply, Pin 8

For reasons of interference protection and surge immunity, the supply voltage (Pin 8) must be provided with an RC circuit as shown in figure 3. Dropper resistor, R_1 , limits the current in case of overvoltage, whereas C_1 smoothes the supply voltage at Pin 8.

Recommended values are: $R_1 = 510 \Omega$, $C_1 = 47 \mu\text{F}$.

The integrated Z-diode (14 V) protects the supply voltage, V_S . Therefore, the operation of the IC is possible between 6 V and 16 V, supplied by V_{Batt} .

However, it is possible to operate the integrated circuit with a 5 V supply, but it should be free of interference voltages. In this case, Pin 7 is connected to Pin 8 as shown in figure 4, and the R_1C_1 circuit is omitted.

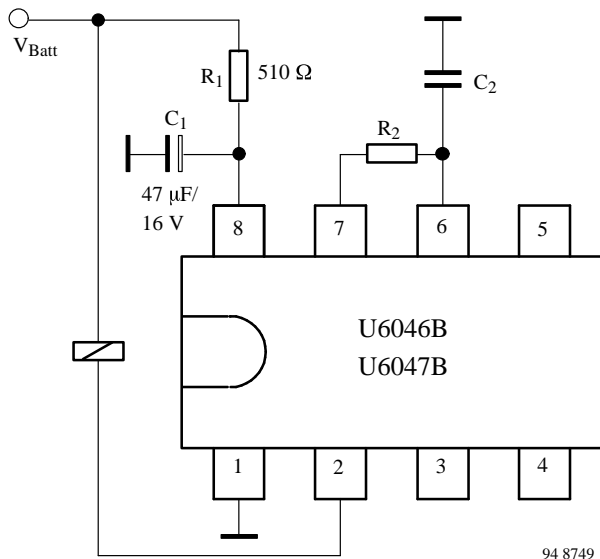

Figure 3. Basic circuit for 12 V supply and oscillator

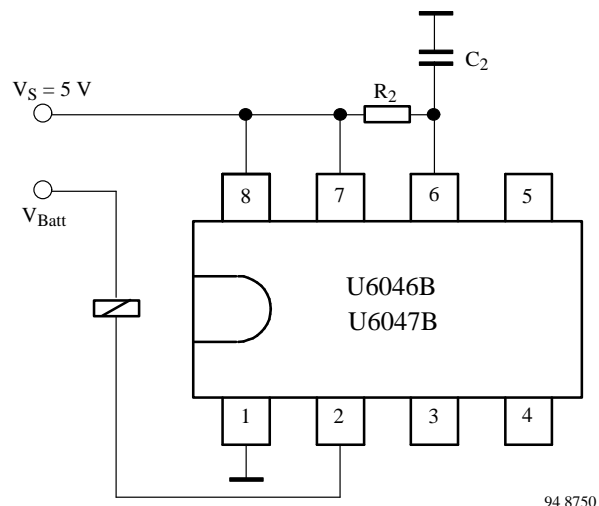

Figure 4. Basic circuit for $V_S = 5 \text{ V}$

Oscillator, Pin 6

Oscillator frequency, f , is determined mainly by the R_2C_2 circuit. Resistance, R_2 , determines the charge time, and the integrated resistance ($2\text{ k}\Omega$) is responsible for discharge time. For the stability of the oscillator frequency, it is recommended that the selected R_2 value be much greater than the internal resistance ($2\text{ k}\Omega$) because the temperature response and the tolerances of the integrated resistance are considerably greater than the external resistance value.

Oscillator frequency, f , is calculated as follows:

$$f = \frac{1}{t_1 + t_2}$$

where

$$t_1 = \text{charge time} = \alpha_1 \times R_2 \times C_2$$

$$t_2 = \text{discharge time} = \alpha_2 \times 2\text{ k}\Omega \times C_2$$

α_1 and α_2 are constants as such

$$\alpha_1 = 0.833 \text{ and } \alpha_2 = 1.551 \text{ when } C_2 = 470\text{ pF to } 10\text{ nF}$$

$$\alpha_1 = 0.746 \text{ and } \alpha_2 = 1.284 \text{ when } C_2 = 10\text{ nF to } 4700\text{ nF}$$

The debounce time, t_3 , and the delay time, t_d , depend on the oscillator frequency, f , as follows:

$$t_3 = 6 \times \frac{1}{f}$$

$$t_d = 73728 \times \frac{1}{f}$$

Table 1 shows relationships between t_3 , t_d , C_2 , R_2 and frequencies from 1 Hz to 20 kHz.

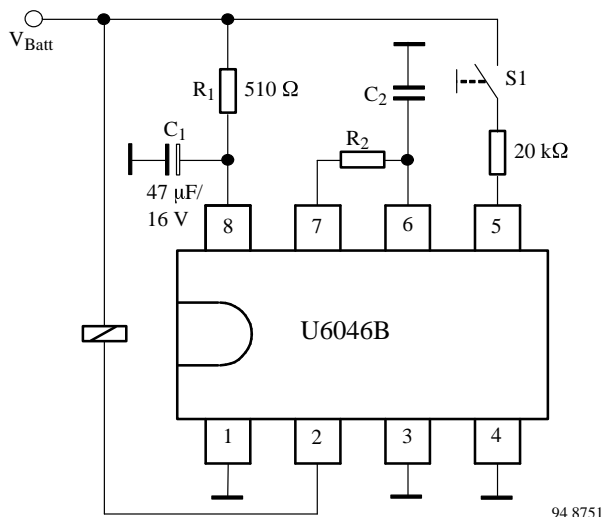

Figure 5. TOGGLE function U6046B

Relay Control Output

The relay control output is an open collector Darlington circuit with an integrated 23-V Z-diode for limitation of the inductive cut-off pulse of the relay coil. The maximum static collector current must not exceed 300 mA and saturation voltage is typically 1.1 V @ 200 mA.

Interference Voltages and Load-Dump

The IC supply is protected by R_1 , C_1 , and an integrated Z-diode, while the inputs are protected by a series resistor, integrated Z-diode and RF capacitor (refer to Figures 10 and 11).

The relay control output is protected via the integrated 23-V Z-diode in the case of short interference peaks. It is switched to conductive condition for a battery voltage of greater than approx. 40 V in the case of load-dump. The output transistor is dimensioned so that it can withstand the current produced.

Power-on Reset

When the operating voltage is switched on, an internal power-on reset pulse (POR) is generated which sets the logic of the circuits to a defined initial condition. The relay output is disabled.

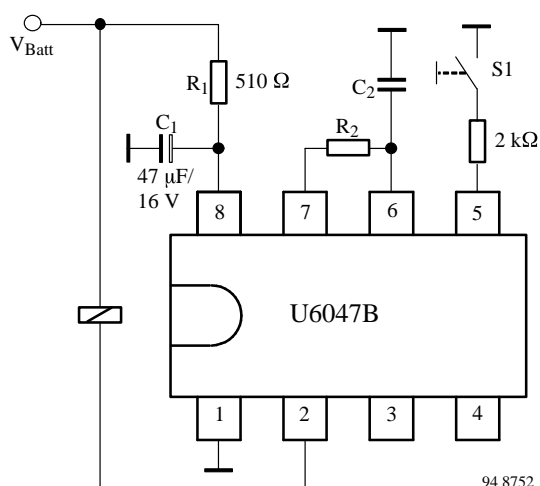

Figure 6. TOGGLE function U6047B

Relay Control Output Behavior, Pin 2

Time functions (relay output) can be started or interrupted by the three inputs i.e., ON, OFF or TOGGLE (Pins 3, 4 and 5).

The relay becomes active if the time function is triggered, and the relay contact is interrupted after the elapse of delay time, t_d . There are two input possibilities:

Toggle Input, Figures 5 and 6

When the push-button (TOGGLE) switch, S_1 , is pressed for the first time, the relay becomes active after the debounce time, t_3 , i.e., the relay output, Pin 2, is active.

Renewed operation of S_1 causes the interruption of the relay contact and the relay is disabled. Each operation of the toggle switch, S_1 , changes (alters) the condition of the relay output when the debounce time, t_3 , is exceeded i.e., the TOGGLE function.

If the relay output is not disabled by pressing the switch S_1 , the output is active until the delay time, t_d , is over.

ON, OFF Inputs, Pins 3 and 4, Figures 7 and 8

To avoid simultaneous operation of both inputs, Pin 3 (ON) and Pin 4 (OFF), use of two-way contact with centre-off position with spring returns (also known as rocker-actuated switch) is recommended.

Pressing the push-button switch (Pin 3-ON) leads to the activation of the relay after the debounce time, t_3 ,

whereas the switching of the Pin 4 switch correspondingly leads to the relay being de-energized. If the relay is not de-energized by the push-button switch, it becomes disabled after the delay time, t_d , is over.

Combined operation, "TOGGLE and ON/OFF" is not possible due to the fact that there is only one debouncing circuit. Debouncing functions on both sides i.e., whenever S_1 is ON or OFF.

If Pin 3 (input ON) is continuously closed, the delay time, t_d , still elapses and the relay is interrupted. This can be used to generate a defined power-on-reset pulse to trigger, for example, a delay time, t_d , when the battery voltage, V_{Batt} , is applied.

Figure 10 shows the input circuit of U6046B. It has an integrated pull-down resistance (20 k Ω), RF capacitor (15 pF) and Z-diode (7 V). It reacts to voltages greater than 2 V. The external protective resistor has a value of 20 k Ω and the push-button switch, S , is connected to the battery as shown in the diagram.

Contact current, I , is calculated as follows:

$$I = \frac{V_{Batt} - V_Z}{R(= 20 \text{ k}\Omega)} \quad \text{where } V_{Batt} = 12 \text{ V}, V_Z = 7 \text{ V}$$

$$I = \frac{(12-7) \text{ V}}{20 \text{ k}\Omega} \approx 0.25 \text{ mA}$$

It can be increased by connecting a 5.6 k Ω resistor from the push-button switch to ground as shown in figure 18.

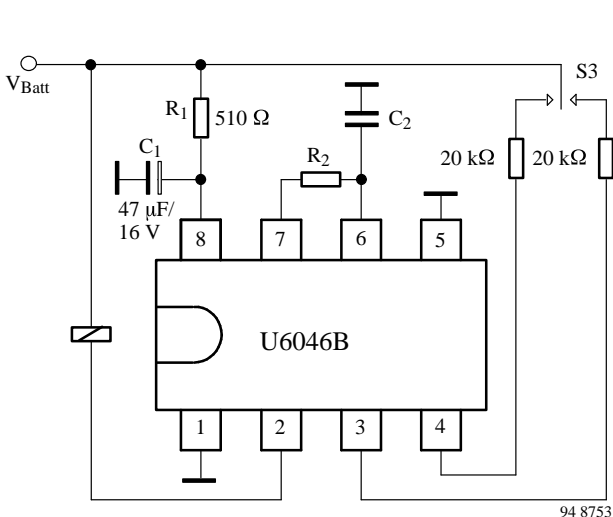

Figure 7. ON/OFF function U6046B

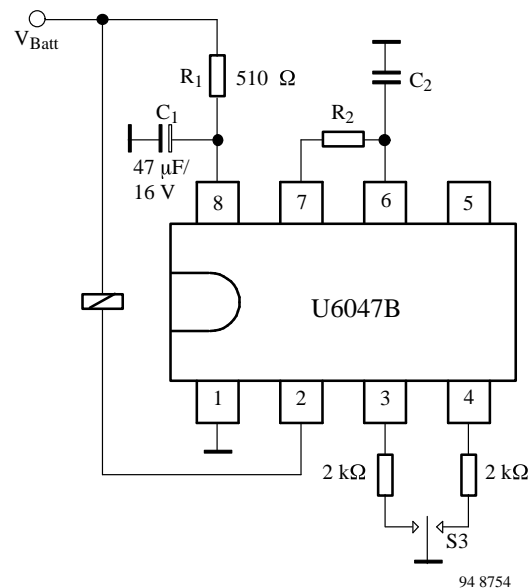

Figure 8. ON/OFF function U6047B

Figure 11 shows the input circuit of U6047B. It has an integrated pull-up resistance (100 kΩ), RF capacitor (15 pF) and Z-diode (7 V). The circuit reacts to voltages less than 2 V. The external protective resistance has a value of 2 kΩ and the push-button switch is connected to GND. Contact current, I, is calculated as follows:

$$I \approx \frac{V_s}{(100 \text{ k}\Omega + 2 \text{ k}\Omega)} \quad \text{when } V_{\text{Batt}} = 12 \text{ V}$$

$$I \approx 0.1 \text{ mA}$$

It can be increased by connecting a 5.6 kΩ resistor from the push-button-switch to V_{Batt} as shown in figure 19.

The connecting diodes prevent the current flow to the input of the Z-diodes when the rocker actuated-switch is in open-state (current-consumption only in standby-mode). If necessary, these diodes can be omitted.

Timing Waveform

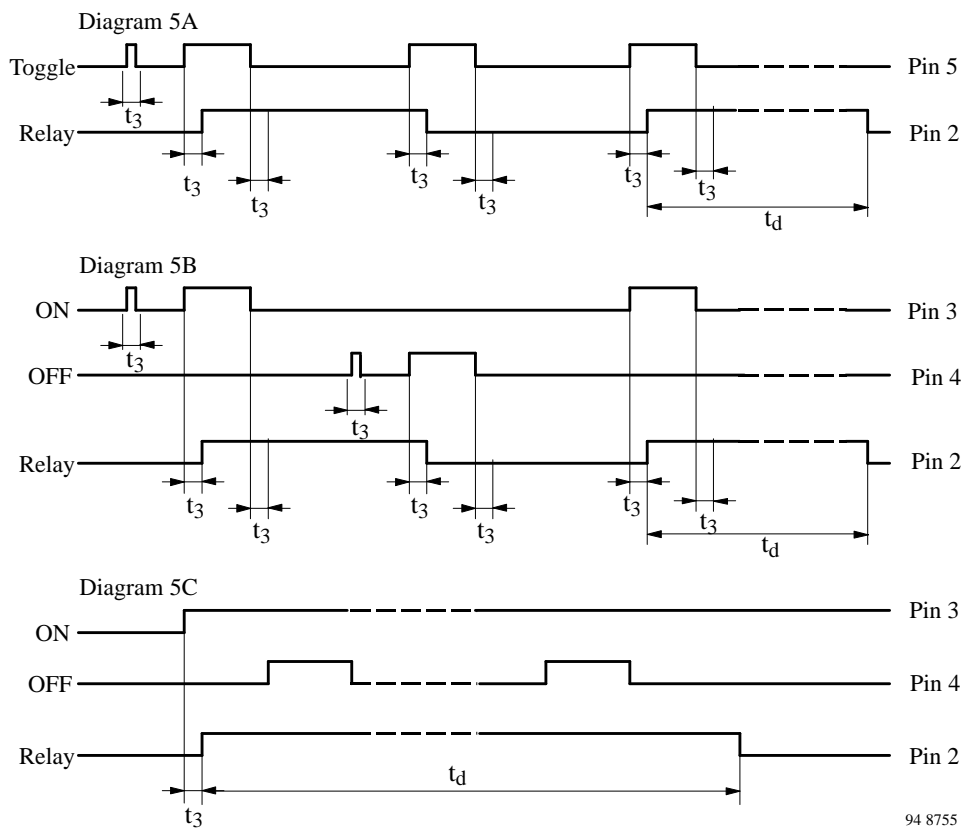

Figure 9. Behavior of the relay control output as a function of input condition

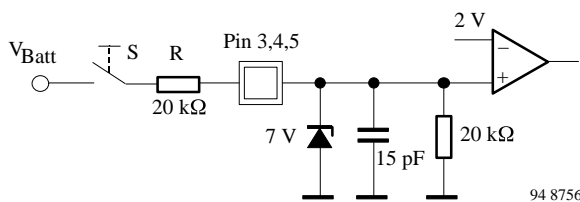

Figure 10. Input circuit U6046B

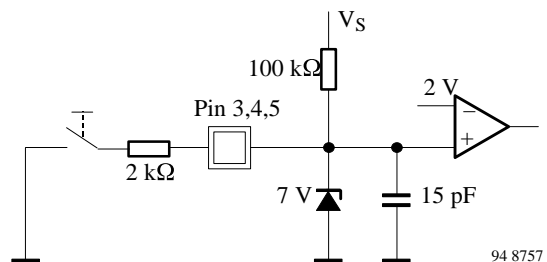

Figure 11. Input circuit U6047B

Absolute Maximum Ratings

Parameters	Symbol	Value	Unit
Operating voltage, static, 5 min	V_{Batt}	24	V
Ambient temperature range	T_{amb}	-40 to +125	°C
Storage temperature range	T_{stg}	-55 to +125	°C
Junction temperature	T_j	150	°C

Thermal Resistance

Parameters	Symbol	Maximum	Unit
Junction ambient DIP8	R_{thJA}	110	K/W
SO8	R_{thJA}	160	K/W

Electrical Characteristics

$V_{Batt} = 13.5\text{ V}$, $T_{amb} = 25^\circ\text{C}$, reference point ground, figure 2, unless otherwise specified

Parameters	Test Conditions / Pin	Symbol	Min	Typ	Max	Unit
Operating voltage	$R_1 \geq 510\ \Omega$ $t < 5\text{ min}$ $t < 60\text{ min}$	V_{Batt}	6		16 24 18	V
5 V supply	Without R_1, C_1 figure 4 Pins 7 and 8	V_8, V_7	4.3		6.0	V
Stabilized voltage	$V_{Batt} = 12\text{ V}$ Pin 7	V_7	5.0	5.2	5.4	V
Undervoltage threshold	Power on reset	V_S	3.0		4.2	V
Supply current	All push buttons open, Pin 8	I_S		1.3	2.0	mA
Internal Z-diode	$I_8 = 10\text{ mA}$ Pin 8	V_Z	13.5	14	16	V
Relay control output Pin 2						
Saturation voltage	$I_2 = 200\text{ mA}$ $I_2 = 300\text{ mA}$	V_2		1.2	1.5	V
Leakage current	$V_2 = 14\text{ V}$	I_{lkg}		2	100	μA
Output current		I_2			300	mA
Output pulse current						
Load dump pulse	$t \leq 300\text{ ms}$	I_2			1.5	A
Internal Z-diode	$I_2 = 10\text{ mA}$	V_Z	20	22	24	V
Oscillator input $f = 0.001\text{ to }40\text{ kHz}$, see table 1 Pin 6						
Internal discharge resistance	$V_6 = 5\text{ V}$	R_6	1.6	2.0	2.4	$\text{k}\Omega$
Switching voltage	Lower Upper	V_{6L} V_{6H}	0.9 2.8	1.1 3.1	1.4 3.5	V
Input current	$V_6 = 0\text{ V}$	$-I_6$			1	μA
Switching times						
Debounce time		t_3	5		7	cycles
Delay time		t_d	72704		74752	cycles
Inputs ON, OFF, TOGGLE Pins 3, 4 and 5						
Switching threshold voltage		$V_{3,4,5}$	1.6	2.0	2.4	V
Internal Z-diode	$I_{3,4,5} = 10\text{ mA}$	V_Z	6.5	7.1	8.0	V
Pull-down resistance	$V_{3,4,5} = 5\text{ V}$ U 6046 B	$R_{3,4,5}$	13	20	50	$\text{k}\Omega$
Pull-up resistance	$V_{3,4,5} = 0\text{ V}$ U 6047 B	$R_{3,4,5}$	70	100	140	$\text{k}\Omega$

Table 1. Oscillator frequency, debounce time, delay time. dimensioning

Fre- quency f	De- bounce time t ₃	Delay time t _d		C ₂ nF	R ₂ kΩ
		min	s		
1	6000	1229		4700	280
2	3000	614		1000	650
3	2000	410		1000	440
4	1500	307		1000	330
5	1200	246		1000	260
6	1000	205		1000	220
7	857	176		1000	190
8	750	154		1000	160
9	667	137		1000	140
10	600	123		1000	130
20	300	61		100	650
30	200	41		100	440
40	150	31		100	330
50	120	25		100	260
60	100	20		100	220
70	86	18		100	190
80	75	15		100	160
90	67	14		100	140
100	60	12		100	130
200	30		369	10	600
300	20		246	10	400
400	15		184	10	300
500	12		147	10	240
600	10		123	10	200

Fre- quency f ₀	De- bounce time t ₃	Delay time t _d		C ₂ nF	R ₂ kΩ
		min	s		
700	9.00		105	10	170
800	8.00		92	10	150
900	7.00		82	10	130
1000	6.00		74	10	120
2000	3.00		37	1	600
3000	2.00		25	1	400
4000	1.50		18	1	300
5000	1.20		15	1	240
6000	1.00		12	1	200
7000	0.86		11	1	170
8000	0.75		9	1	150
9000	0.67		8	1	130
10000	0.60		7	1	120
11000	0.55		6.7	1	110
12000	0.50		6.1	1	99
13000	0.46		5.7	1	91
14000	0.43		5.3	1	85
15000	0.40		4.9	1	79
16000	0.38		4.6	1	74
17000	0.35		4.3	1	70
18000	0.33		4.1	1	66
19000	0.32		3.9	1	62
20000	0.30		3.7	1	59

3. Applications

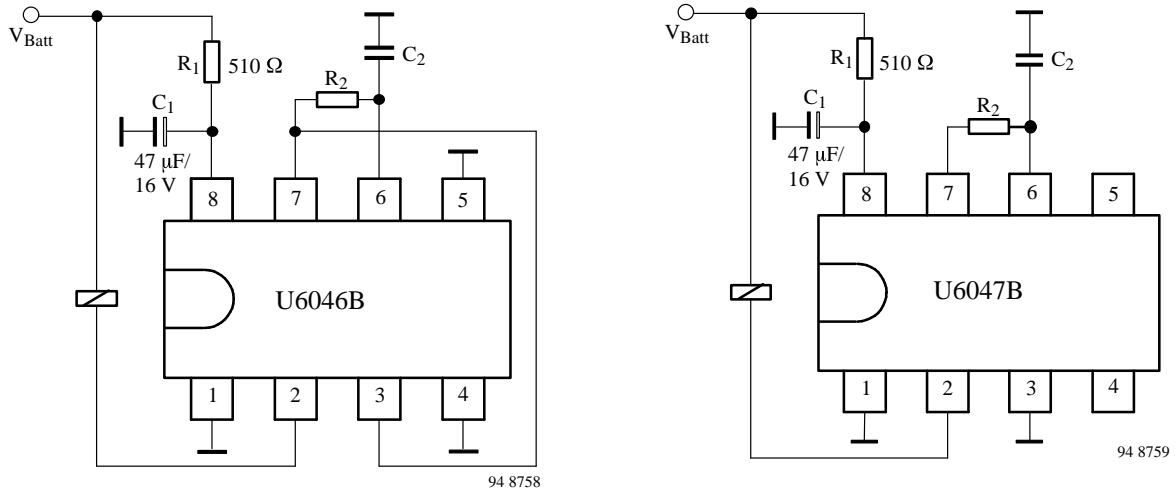

Figure 12. Generation of a monostable delay time, t_d , caused by applying the operating voltage V_{Batt} , not externally deactivatable.

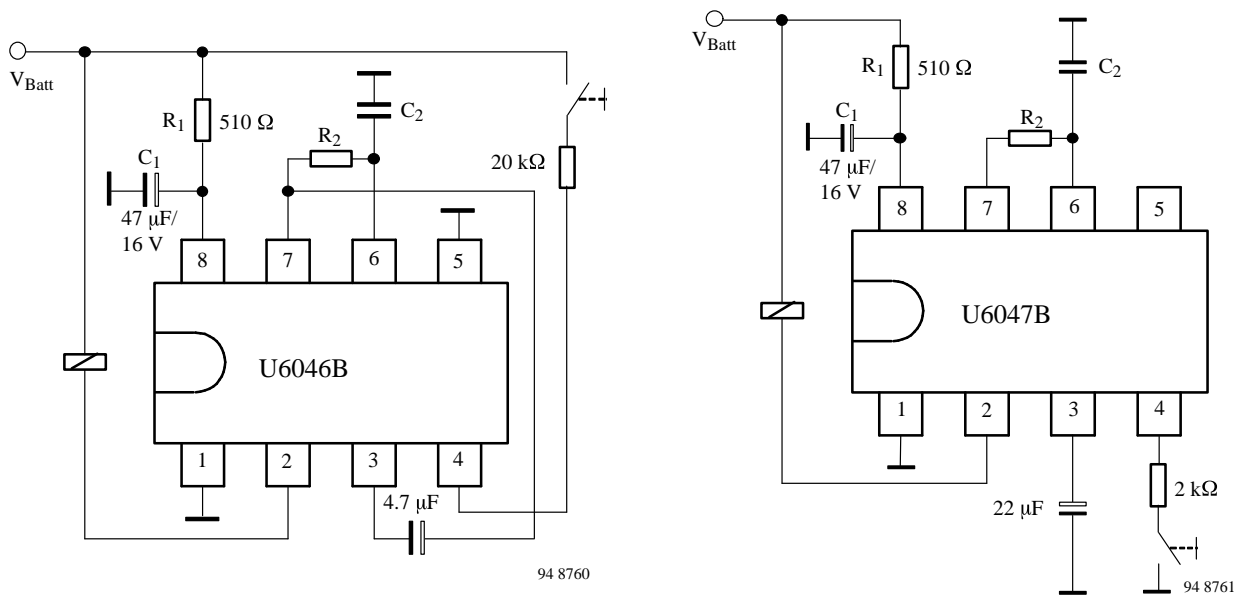

Figure 13. Generation of a monostable delay time, t_d , by applying the operating voltage V_{Batt} , deactivatable by the OFF push-button

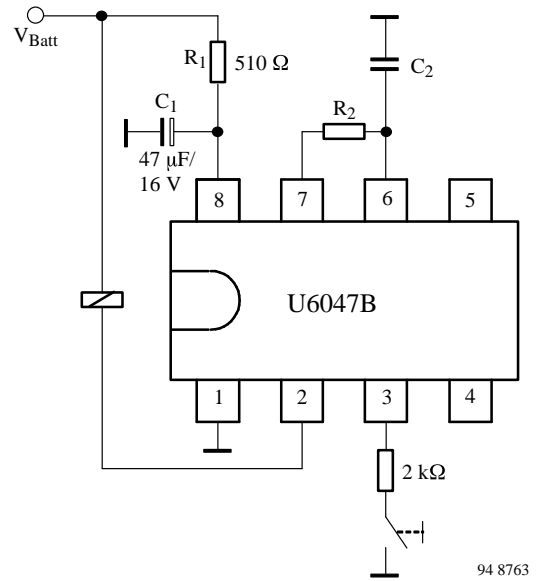
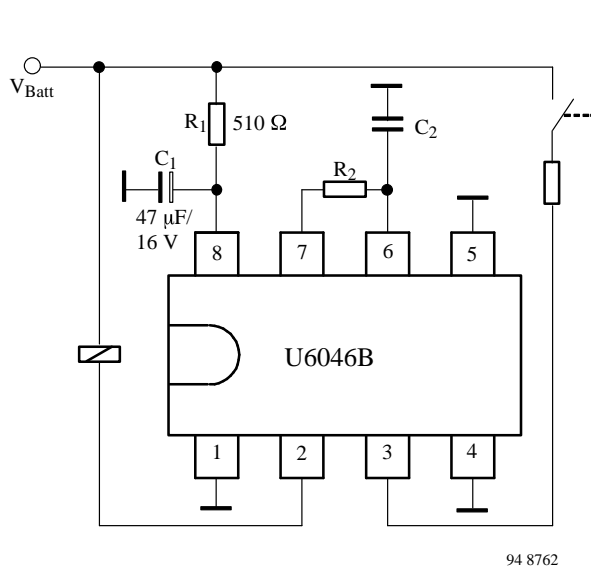

Figure 14. Monostable delay time, t_d , can be activated by the ON push-button, not externally deactivatable

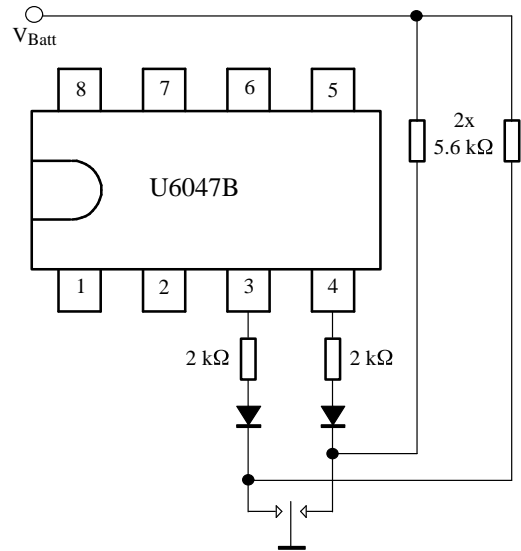
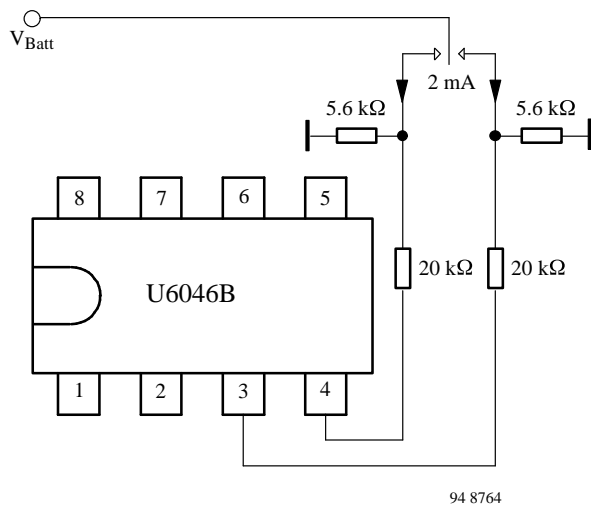

Figure 15. Increasing the contact current by parallel resistors

U6046B / U6047B

Dimensions in mm

Package DIP8

Dimensions in mm

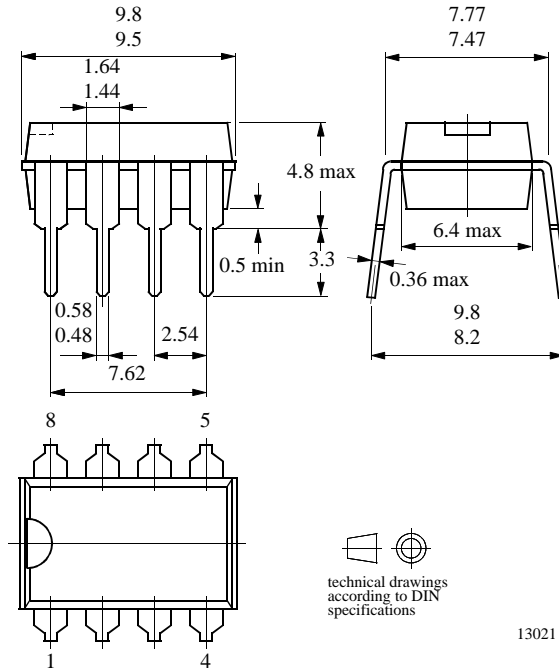

Package SO8

Dimensions in mm

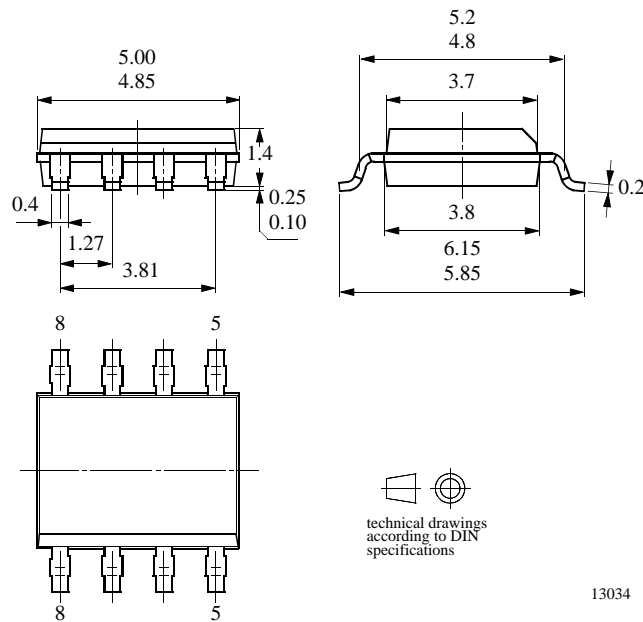

Ozone Depleting Substances Policy Statement

It is the policy of **TEMIC TELEFUNKEN microelectronic GmbH** to

1. Meet all present and future national and international statutory requirements.
2. Regularly and continuously improve the performance of our products, processes, distribution and operating systems with respect to their impact on the health and safety of our employees and the public, as well as their impact on the environment.

It is particular concern to control or eliminate releases of those substances into the atmosphere which are known as ozone depleting substances (ODSs).

The Montreal Protocol (1987) and its London Amendments (1990) intend to severely restrict the use of ODSs and forbid their use within the next ten years. Various national and international initiatives are pressing for an earlier ban on these substances.

TEMIC TELEFUNKEN microelectronic GmbH semiconductor division has been able to use its policy of continuous improvements to eliminate the use of ODSs listed in the following documents.

1. Annex A, B and list of transitional substances of the Montreal Protocol and the London Amendments respectively
2. Class I and II ozone depleting substances in the Clean Air Act Amendments of 1990 by the Environmental Protection Agency (EPA) in the USA
3. Council Decision 88/540/EEC and 91/690/EEC Annex A, B and C (transitional substances) respectively.

TEMIC can certify that our semiconductors are not manufactured with ozone depleting substances and do not contain such substances.

We reserve the right to make changes to improve technical design and may do so without further notice.

Parameters can vary in different applications. All operating parameters must be validated for each customer application by the customer. Should the buyer use TEMIC products for any unintended or unauthorized application, the buyer shall indemnify TEMIC against all claims, costs, damages, and expenses, arising out of, directly or indirectly, any claim of personal damage, injury or death associated with such unintended or unauthorized use.

TEMIC TELEFUNKEN microelectronic GmbH, P.O.B. 3535, D-74025 Heilbronn, Germany
Telephone: 49 (0)7131 67 2831, Fax number: 49 (0)7131 67 2423