

Wiper Control for Intermittent and Wipe/ Wash Mode

Description

The U842B circuit is designed as an interval and wipe/ wash timer for automotive wiper control. The interval pause can be set in a range from 3 s to 11 s by an external 1-k Ω potentiometer. Wipe/wash mode has priority over the interval mode. The U842B controls the wiper motor with/without park switch signal.

The integrated relay driver is protected against short circuits and is switched to conductive condition in the case of a load-dump. With only a few external components, protection against RF interference and transients (ISO/TR 7637-1/3) can be achieved.

Features

- Interval input: low side
- Wipe/ wash input: low side
- Park input: high side (park position)
- Output driver protected against short circuit
- All time periods determined by RC oscillator
- Fixed relay activation time of 500 ms
- Adjustable interval pause from 3 s to 11 s
- Fixed pre-wash delay of 400 ms
- Dry wiping
 - With park switch signal: 3 cycles
 - Without park switch signal: 2.8 s
- Inputs INT, WASH and PARK digitally debounced
- All inputs with integrated RF protection
- Load-dump protection and interference protection according to ISO 7637-1/3 (DIN 40839)

Application

Digital/ wipe-wash control for rear or front wiper

Ordering Information

Extended Type Number	Package	Remarks
U842B	DIP8	
U842B-FP	SO8	

Pin Description

Pin	Symbol	Function
1	INT	Interval input
2	WASH	Wipe/ wash input
3	PARK	Park switch input
4	PAUS	Pause time adjust
5	OSC	Oscillator input
6	V _S	Supply voltage
7	GND	Ground
8	OUT	Relay output

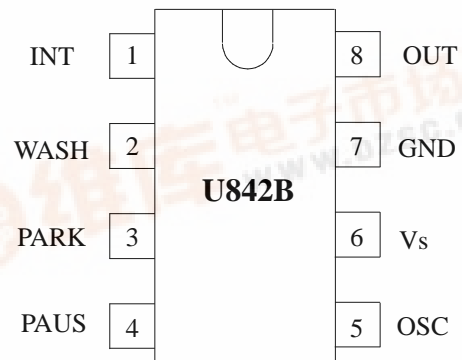

13300

Figure 1. Pinning

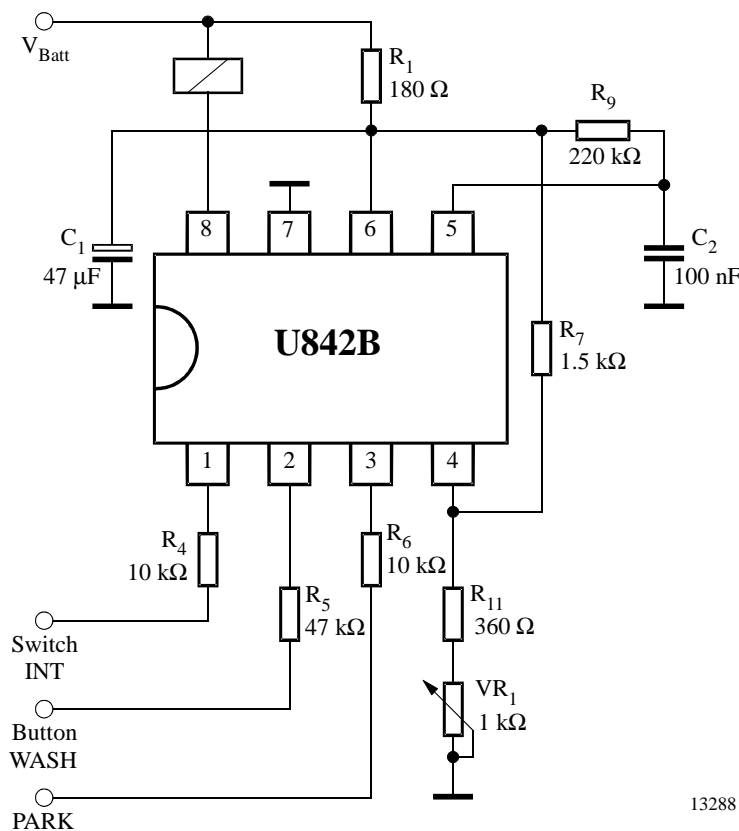

Figure 3. Basic circuitry

Variable Debouncing Times

Debouncing is basically done by counting oscillator clocks starting with the occurrence of any input signal.

Caused by the asynchronism of input signal and IC-clock, the debouncing time may vary in a certain range.

Figure 4 shows the short circuit debouncing as an example:

During the relay activation, a comparator monitors the output current at each positive edge of the clock to load a 3-stage shift register in the case of a detected short circuit condition i.e., $I > 500 \text{ mA}$. With the third edge, the output stage is disabled. Dependent on the short circuit occurrence the delay time may range from 2 to 3 clock cycles.

The timing can be adjusted by variation of the external frequency-determining components (R/C).

The potentiometer at Pin 4 determines the interval pause, which can be varied by adjusting the upper charging

threshold of the oscillator. For all other time periods, an internal voltage divider determines the upper charging threshold of the oscillator (see figure 2).

Timing

Fixed:	
Relay activation time	$t_5 = 160 \times 1/f_0$
Dry wiping	$t_2 = 896 \times 1/f_0$ or 3 cycles
Interval pause	$t_6 = 872 \times 1/f_0$
Switch-on delay INT	$t_{4D} = 8 \times 1/f_0$
Variable:	
Debouncing time INT	$t_4 = 24 \text{ to } 32 \times 1/f_0$
Debouncing time WASH	
1. pre-wash delay	$t_1 = 112 \text{ to } 128 \times 1/f_0$
2. reverse debouncing	$t_{1.R} = 16 \text{ to } 32 \times 1/f_0$
Debouncing time PARK	$t_8 = 6 \text{ to } 8 \times 1/f_0$
Debouncing time SC	$t_7 = 2 \text{ to } 3 \times 1/f_0$

Wipe/ Wash Operation

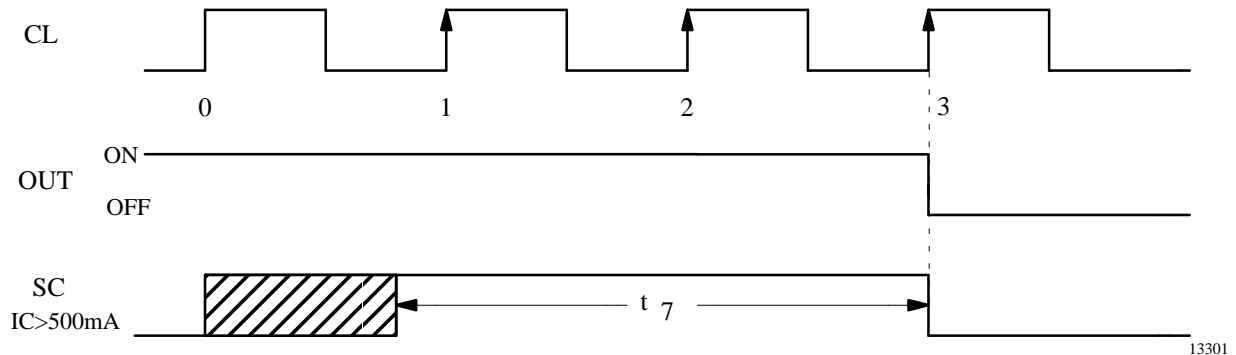

Figure 4. The debouncing of the short circuit detection

Relay Output

The relay output is an open collector Darlington transistor with an integrated 28-V Z-diode for limitation of the inductive cut-out pulse of the relay coil. The maximum static collector current must not exceed 300 mA and the saturation voltage is typically 1.2 V for a current of 200 mA.

The collector current is permanently measured by an integrated shunt, and in the case of a short circuit ($I_C > 500 \text{ mA}$) to V_{bat} , the relay output is stored disabled.

The short circuit buffer is reset by opening the INT and WASH switches. As long as the short condition exists a further activation of these switches will disable the output stage again. Otherwise the normal wipe operation is performed.

In order to avoid short-term disabling caused by current pulses of transients, a 10 ms debounce period (t_7) is provided (see figure 4).

During a load-dump pulse, the output transistor is switched to conductive condition to prevent destruction. The short circuit detection is suppressed during the load-dump.

Interference Voltages and Load-dump

The IC supply is protected by R_1 , C_1 and an integrated 21-V Z-diode. The inputs are protected by a series resistor, integrated 21-V Z-diode and RF capacitor.

The RC-configuration stabilizes the supply of the circuit during negative interference voltages to avoid power-on reset (POR).

The relay output is protected against short interference peaks by an integrated 28-V Z-diode. During load-dump, the relay output is switched to conductive condition if the battery voltage exceeds approximately 30 V. The output transistor is dimensioned so that it can absorb the current produced by the load-dump pulse.

Power-on Reset

When the operating voltage is switched on, an internal power-on reset pulse (POR) is generated which sets the logic of the circuits to defined initial condition. The relay output is disabled, the short circuit buffer is reset.

Functional Description

Interval Function

The circuit is brought to its interval mode with the input switch INT operated for more than 625 ms ($t > t_4 + t_{4D} + t_5$).

This time includes:

- 100 ms debounce time t_4
- 25 ms INT switch-on delay t_{4D}
- 500 ms relay activation time t_5

If the INT input is toggled for $125 \text{ ms} < t < 625 \text{ ms}$, the relay activation time t_5 lapses anyway and the wiper performs one turn. To enable correct interval functioning, the INT input has to be activated afterwards as described.

The beginning of the interval pause depends on the application with or without wiper motor park switch (see figures 5, 6, 7 and 8).

Interval Function with Park-Switch Feedback

During the relay activation time the wiper motor leaves its park position and the park switch changes its potential from V_{Batt} to GND. After the relay is switched off the wiper motor is supplied via the park switch until the park position is reached again. The park switch changes its

potential from GND back to V_{Batt} . With the park switch connected to the park input (Pin 3) the interval pause t_6 starts after the 25 ms debounce time (t_7) is over (see figures 5 and 6).

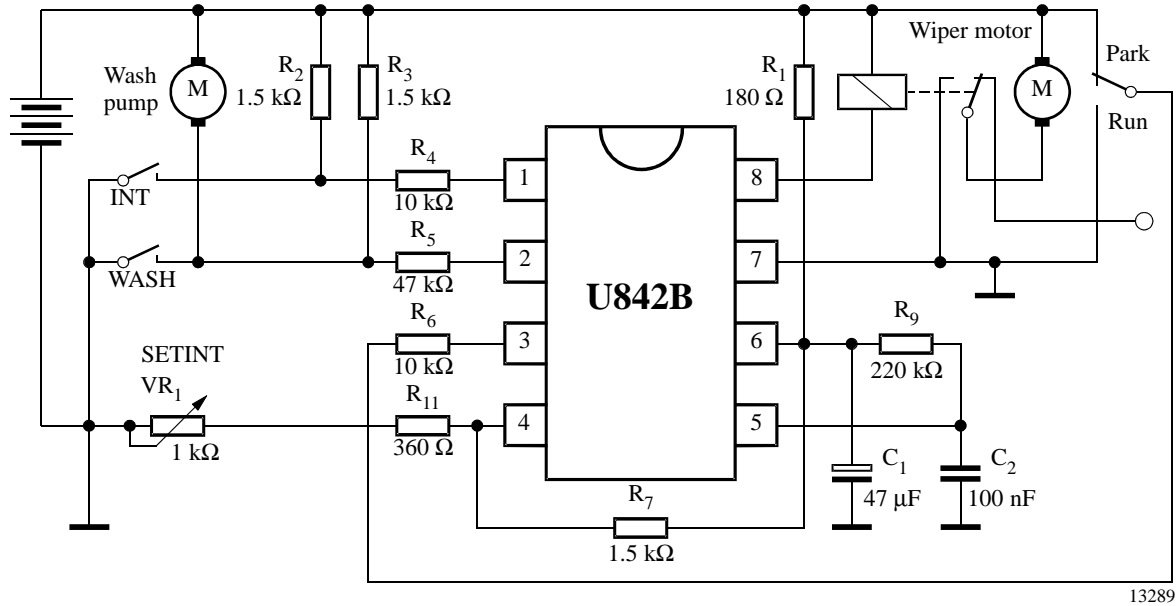

Figure 5. Application circuit with park switch feedback

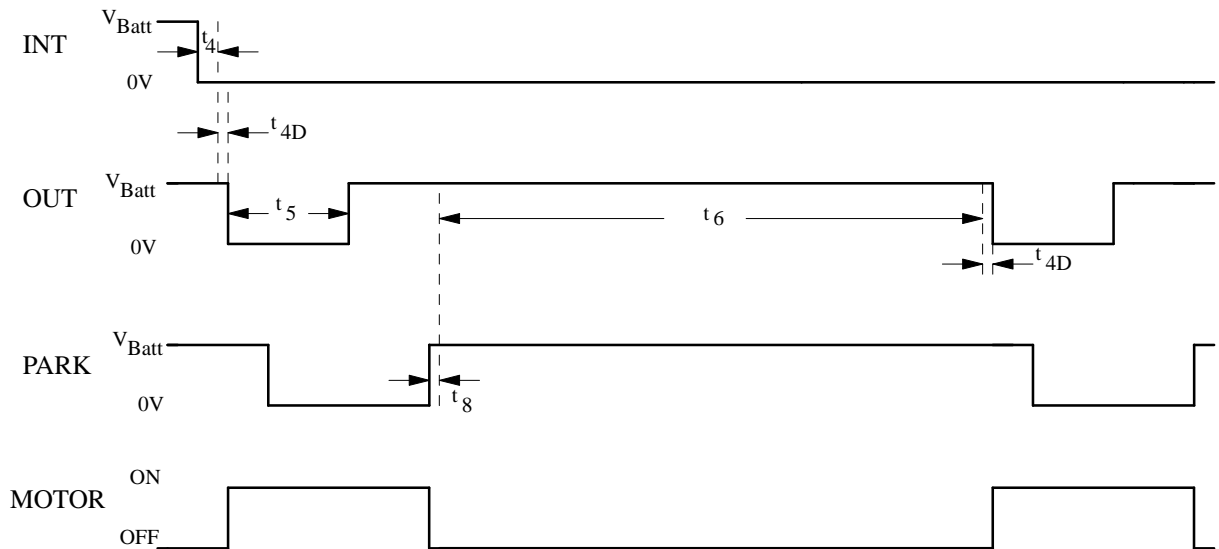
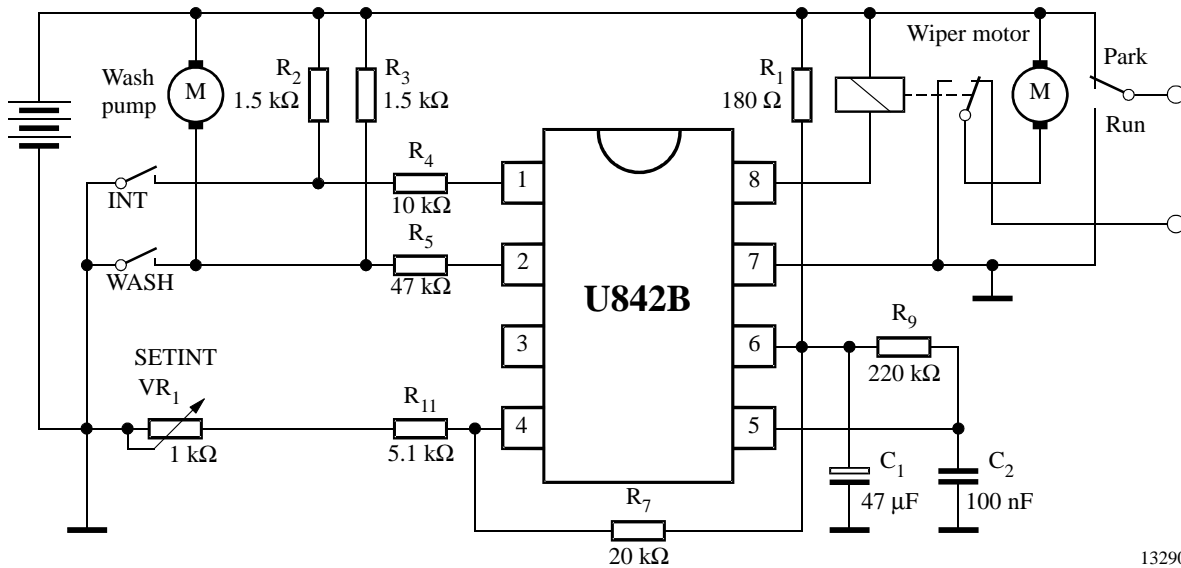

Figure 6. Intermittent circuit function with park position feedback

Interval Function without Park-Switch Feedback

If the park input of the circuit is not connected with the park switch of the wiper motor (see figure 7), the interval pause starts directly after the turn-on time of the relay is over (see figure 8).



13290

Figure 7. Application circuit without park position feedback

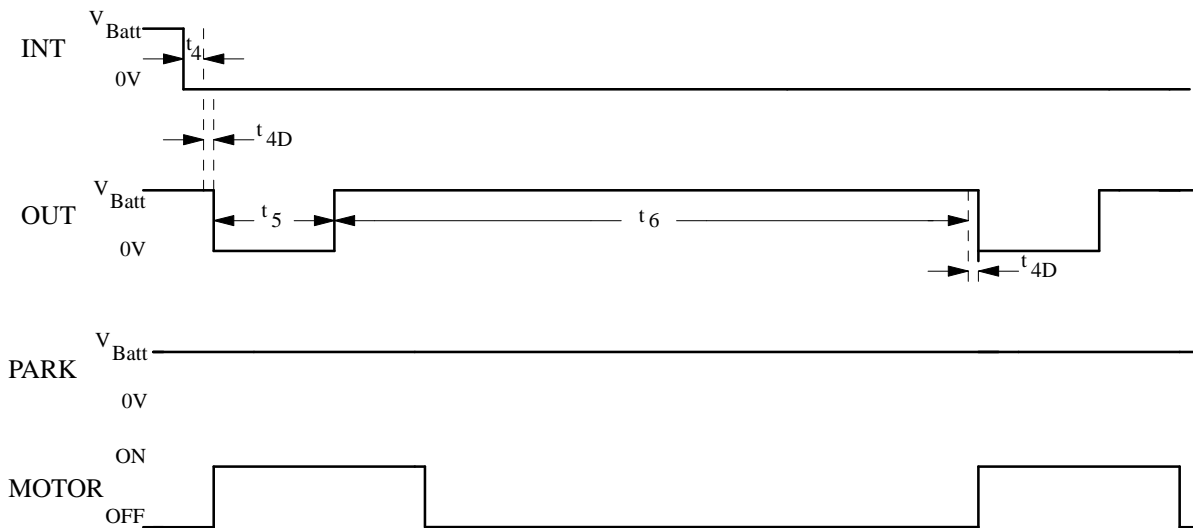

13303

Figure 8. Intermittent circuit function without park position feedback

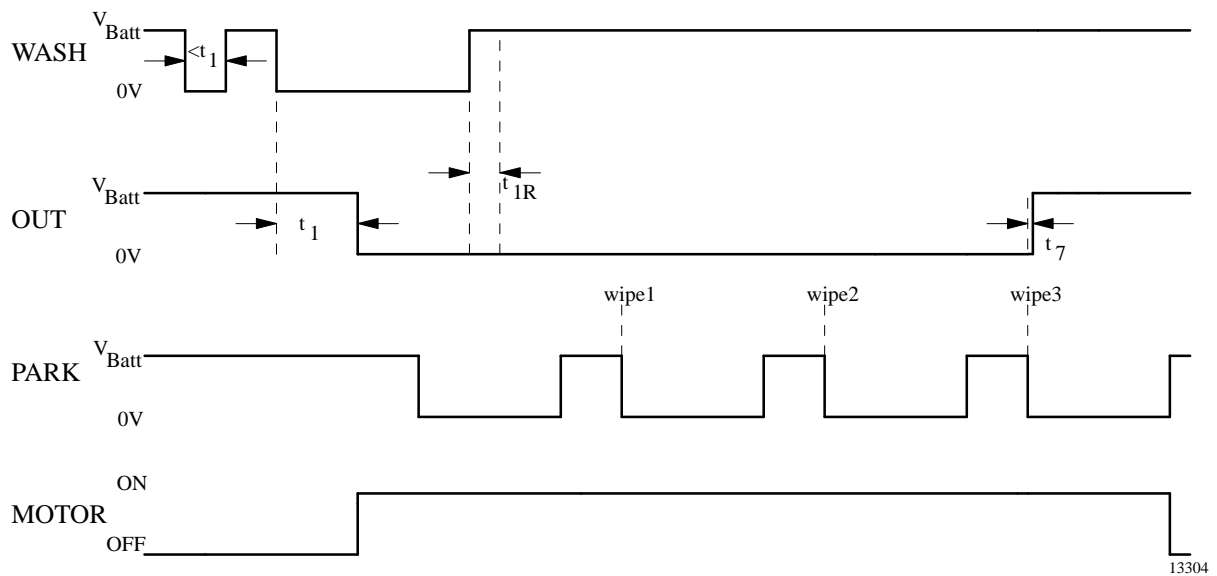

Figure 9. Wash operation with park switch signal

After operating the WASH switch, the relay is activated after the debounce time, t_1 . As long as the switch is pushed, water is sprayed on the windscreen by the wash pump. When it is released, the dry wiping starts after 100 ms reverse debouncing (t_{1R}).

Wipe/ Wash Mode with Park Position Feedback

If the park input of the circuit is connected to the park switch, the dry wiping lasts three full wipe cycles (see

figure 9). During the third cycle, the wiper motor is supplied via the park switch because the relay driver is switched off after the second cycle.

Wipe/ Wash Mode without Park Position Feedback

If U842B is used without the wiper motor's park switch, Pin 3 stays at high potential via its integrated pull-up resistor. Therefore, the driver stage switches off after the fixed dry wiping time t_2 .

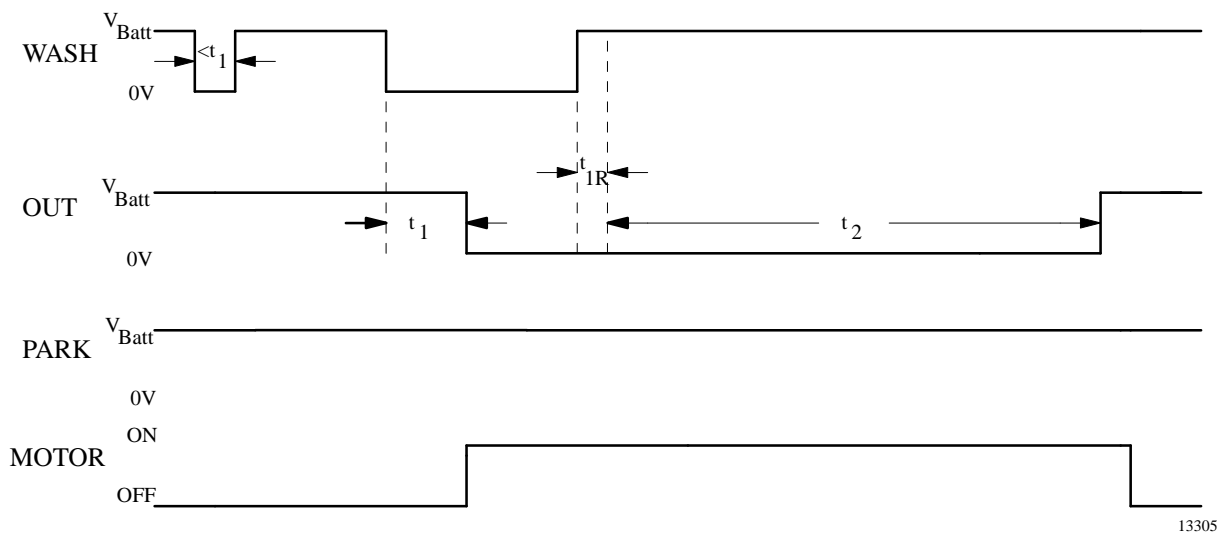

Figure 10. Wash operation without park signal report

Wipe/ Wash Mode Priority

The wipe/wash mode has priority over the interval mode – therefore the interval function is interrupted as soon as the WASH switch is operated longer than the debounce time t_1 . With or without park switch feedback, after relay

activation time is over (no park switch feedback), or after the third wipe (park switch feedback), the interval mode is continued with an interval pause t_6 (see figures 11 and 12).

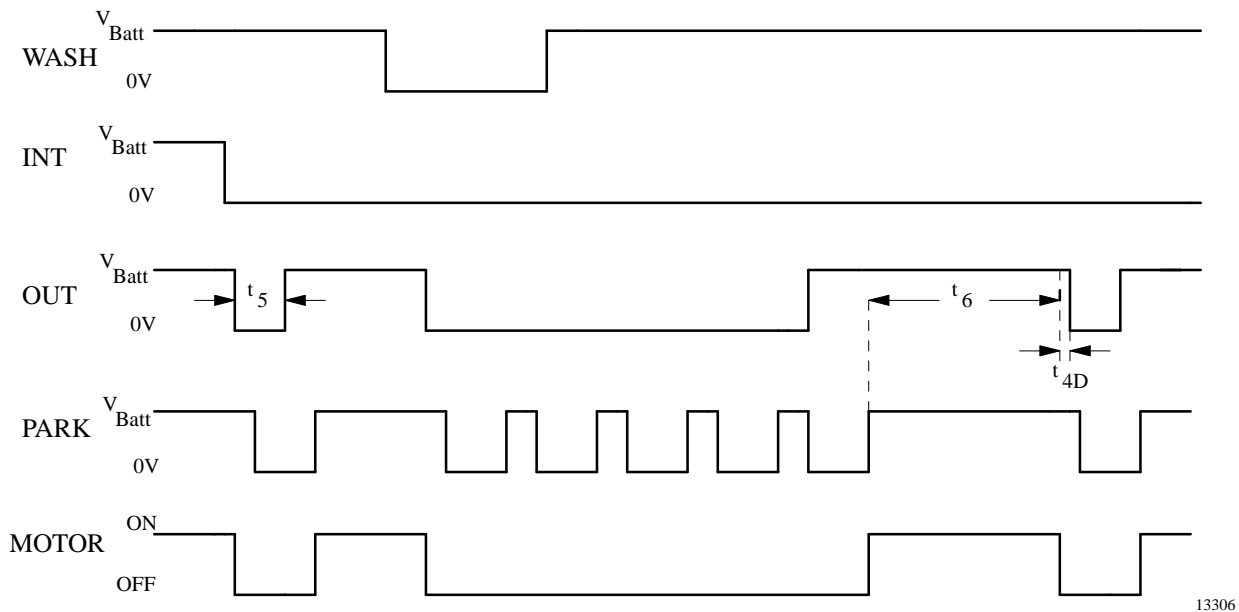

Figure 11. Wipe/ wash priority with park position feedback

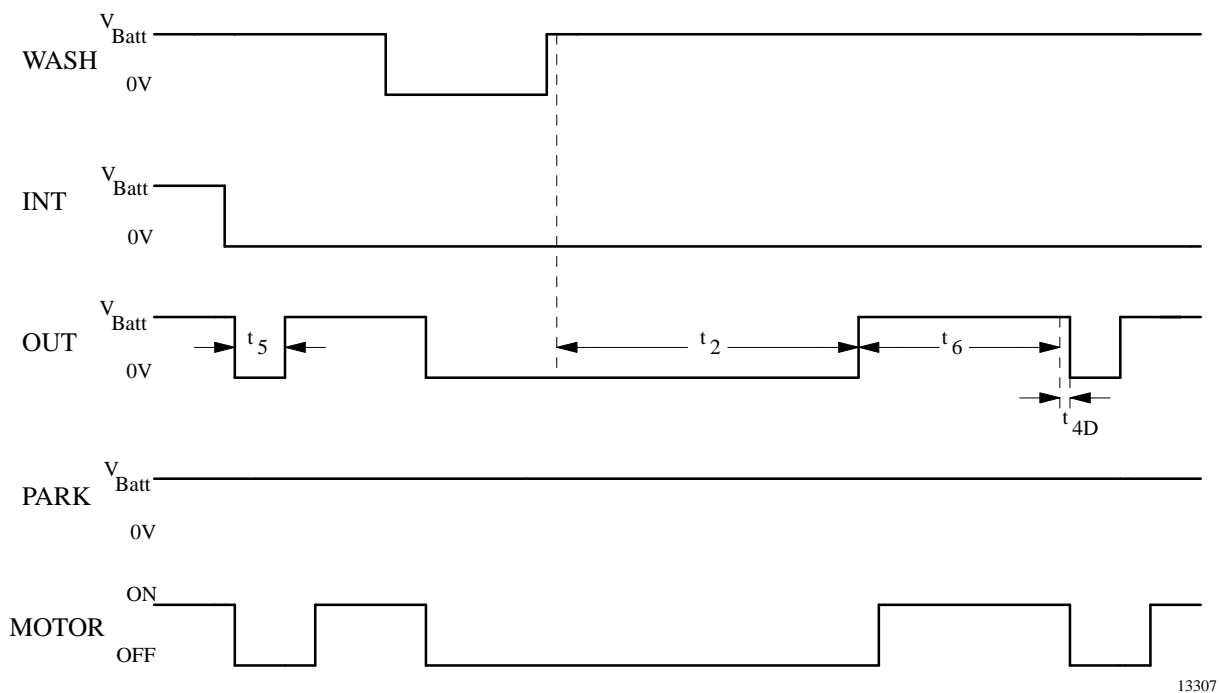

Figure 12. Wash/ wipe priority without park position feedback

Absolute Maximum Ratings

Parameters	Symbol	Value	Unit	
Supply voltage	$t = 60 \text{ s}$	V_{Batt}	24	V
	$t = 600 \text{ s}$	V_{Batt}	18	V
Ambient temperature range	T_{amb}	-30 to +100	°C	
Storage temperature range	T_{stg}	-40 to +100	°C	
Maximum junction temperature	T_{j}	150	°C	

Thermal Resistance

Parameters	Symbol	Maximum	Unit	
Thermal resistance	DIP8	R_{thja}	110	K/W
	SO8	R_{thja}	160	K/W

Electrical Characteristics

$V_{\text{Batt}} = 13.5 \text{ V}$, $T_{\text{amb}} = 25^\circ\text{C}$, reference point ground (Pin 7), circuit with recommended external circuitry (see figure 2)

Parameters	Test Conditions / Pin	Symbol	Min	Typ	Max	Unit
Supply						
Supply-voltage range		V_{S}	9		16	V
Supply current		I_{6}			3	mA
Undervoltage threshold POR		V_{6}		3.5		V
Series resistance		R_{1}		180		Ω
Filter capacitance		C_{1}		47		μF
Internal Z-diode		V_{6}		21		V
INT input Pin 1						
Protective diode		V_{1}		21		V
Internal capacitance		C_{1}		25		pF
Threshold		V_{1}		$0.5 V_{\text{6}}$		Ω
Pull-up resistance		R_{1}		20		k Ω
External series resistance		R_{S}		10		k Ω
PARK input Pin 3						
Protective diode		V_{3}		21		V
Internal capacitance		C_{3}		25		pF
Threshold		V_{3}		$0.5 V_{\text{6}}$		Ω
Pull-up resistance		R_{3}		20		k Ω
External series resistance		R_{S}		10		k Ω
WASH input Pin 2						
Protective diode		V_{2}		21		V
Internal capacitance		C_{2}		25		pF
Threshold		V_{2}		$0.5 V_{\text{6}}$		Ω
Pull-up resistance		R_{2}		100		k Ω
External series resistance		R_{S}		47		k Ω

Parameters	Test Conditions / Pin	Symbol	Min	Typ	Max	Unit
PAUS input		Pin 4				
Protective diode		V ₄		21		V
Internal capacitance		C ₄		25		pF
Relay output		Pin 8				
Saturation voltage 100 mA		V ₈		1.0		V
Saturation voltage 200 mA		V ₈		1.2		V
Relay coil resistance		R _{Rel}	60			Ω
Output current		I ₈			300	mA
Normal operation						
Output pulse current		I ₈			1.5	A
Load-dump						
Internal Z-diode		V ₈		28		V
Short circuit threshold		I ₈	500			mA
Oscillator input		Pin 5				
Oscillator capacitor	Pin 5	C ₂		100		nF
Oscillator resistor	Pins 5 and 6	R ₈		220		kΩ
Basic frequency		f ₀		320		Hz
Lower switching point		V ₅		0.07 V ₆		
Upper switching point	External 1 kΩ pot.	V ₅	0.2 V ₆		0.5 V ₆	
Internal discharge resistance		R ₅		2		kΩ
Protective diode	V _F = forward voltage	V ₅		V _S + V _F		V
Times						
External circuitry – see oscillator input (figure 3)						
Debouncing times:						
INT input		t ₄	50		125	ms
WASH input						
Pre-wash delay		t ₁	260		540	ms
Reverse delay		t _{1,R}	50		125	ms
Park		t ₈	14		37	ms
Short circuit		t ₇	5		12	ms
Switch-on delay (interval mode)		t _{4D}	18		31	ms
Relay activation time		t ₅	400		625	ms
Interval pause		t ₆	2.25		13.75	s
Dry wiping						
Without park switch feedback		t ₂	2.1		3.5	s
With park switch feedback				3		wipes

Package Information

Package DIP8

Dimensions in mm

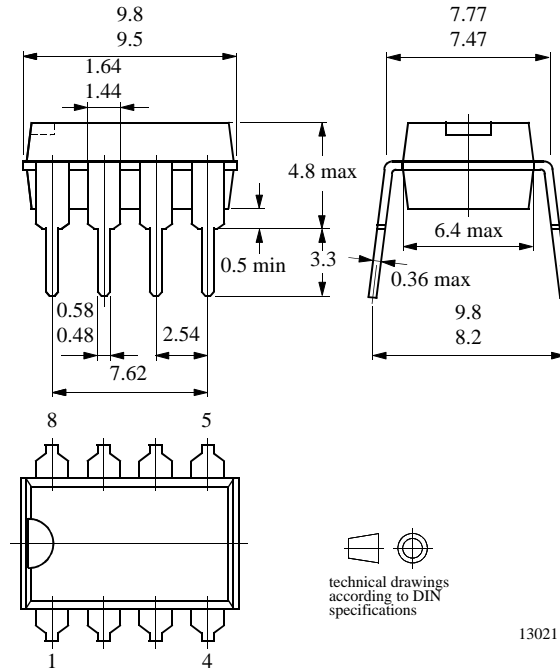

Package SO8

Dimensions in mm

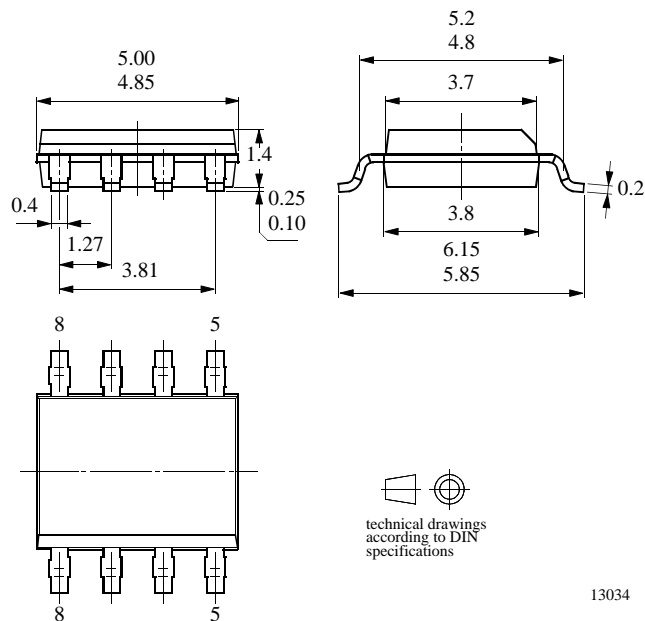

Ozone Depleting Substances Policy Statement

It is the policy of **TEMIC TELEFUNKEN microelectronic GmbH** to

1. Meet all present and future national and international statutory requirements.
2. Regularly and continuously improve the performance of our products, processes, distribution and operating systems with respect to their impact on the health and safety of our employees and the public, as well as their impact on the environment.

It is particular concern to control or eliminate releases of those substances into the atmosphere which are known as ozone depleting substances (ODSs).

The Montreal Protocol (1987) and its London Amendments (1990) intend to severely restrict the use of ODSs and forbid their use within the next ten years. Various national and international initiatives are pressing for an earlier ban on these substances.

TEMIC TELEFUNKEN microelectronic GmbH semiconductor division has been able to use its policy of continuous improvements to eliminate the use of ODSs listed in the following documents.

1. Annex A, B and list of transitional substances of the Montreal Protocol and the London Amendments respectively
2. Class I and II ozone depleting substances in the Clean Air Act Amendments of 1990 by the Environmental Protection Agency (EPA) in the USA
3. Council Decision 88/540/EEC and 91/690/EEC Annex A, B and C (transitional substances) respectively.

TEMIC can certify that our semiconductors are not manufactured with ozone depleting substances and do not contain such substances.

We reserve the right to make changes to improve technical design and may do so without further notice.

Parameters can vary in different applications. All operating parameters must be validated for each customer application by the customer. Should the buyer use TEMIC products for any unintended or unauthorized application, the buyer shall indemnify TEMIC against all claims, costs, damages, and expenses, arising out of, directly or indirectly, any claim of personal damage, injury or death associated with such unintended or unauthorized use.

TEMIC TELEFUNKEN microelectronic GmbH, P.O.B. 3535, D-74025 Heilbronn, Germany
Telephone: 49 (0)7131 67 2831, Fax number: 49 (0)7131 67 2423